

Introduction (1)

GI-1

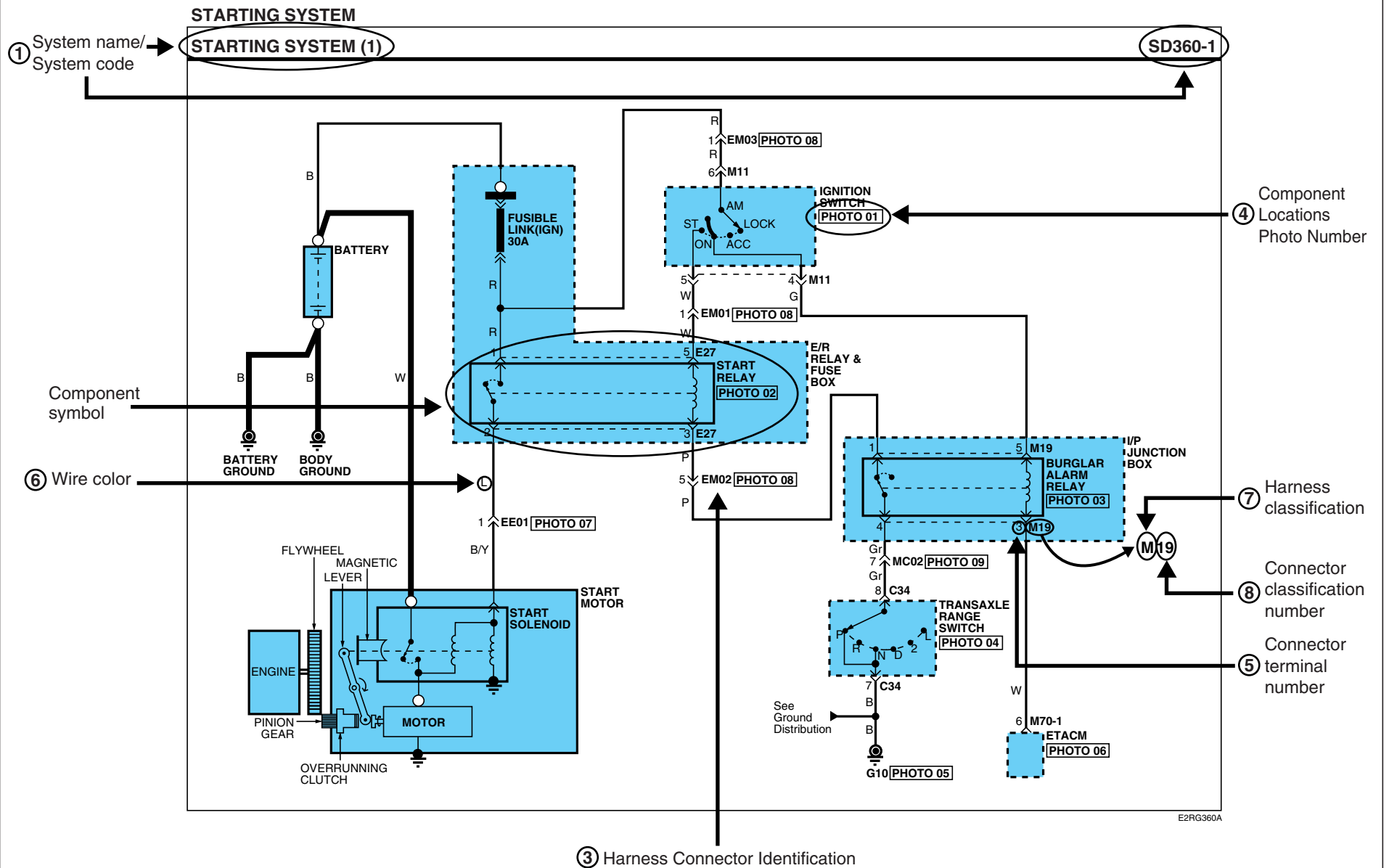

E2RG360A

# INTRODUCTION

## Introduction (2)

GI-2

### STARTING SYSTEM

#### STARTING SYSTEM (2)

SD360-2

② Connector configurations (components)

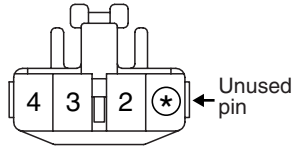
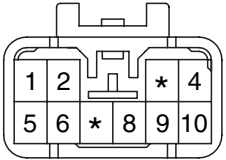
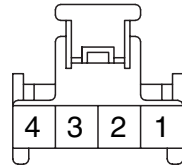
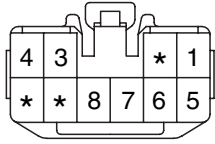
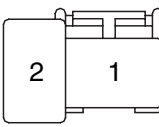
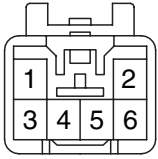
<p><b>M05</b></p>  <p>Unused pin</p> <p>KET_090II_04F_W</p>	<p><b>M06</b></p>  <p>KET_090II_10M_W</p>	<p><b>M11</b></p>  <p>KUM_AR_04F_W</p>	<p><b>M13</b></p>  <p>KET_090II_10F_W</p>
<p><b>M67</b></p>  <p>AMP_PLM2_02F_B</p>	<p><b>M81</b></p>  <p>KET_090II_06M_W</p>	<p><b>BLANK</b></p>	<p><b>BLANK</b></p>

E2RG360B

Connector Code Definition

### M05

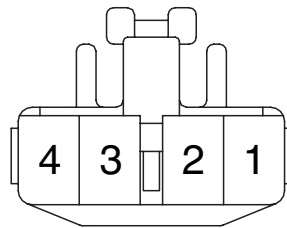

KET\_090II\_04F\_W

a b c d e

a : Connector manufacturer

b : Terminal series number

c : The number of connector terminals

d : Connector pin configuration

Female Pin : F

Male Pin : M

e : Connector color abbreviations

- B (Black)
- Br (Brown)
- G (Green)
- Gr (Gray)
- L (Blue)
- R (Red)
- W (White)
- Y (Yellow)

# INTRODUCTION

## Introduction (3)

GI-3

### ① Pages by system/ Name of schematic diagram

- Each schematic diagram provides data related to current flow, switch functionality (where applicable), and related circuit information.
- Understanding circuit operation is a critical component of effective diagnosis.
- The schematic diagram index provides a guide to locating the correct circuit.

### ② Connector configuration (components)

- The pages following the schematic diagrams contain data related to component connector configuration. Each page shows a terminal side view of the connector. Refer to the "Connector View and Numbering Order" section in this document for information related to terminal numbering.  
NOTE : a "\*" symbol in place of a terminal number indicates an unused terminal (connector cavity will be empty).

### ③ Connector configurations (connection between harnesses)

- The "Connector Configurations" section identifies connectors that are used to join harnesses together; junction connectors for common power and ground wires are also identified in this section. Male and female connector views are shown where applicable.

EM02

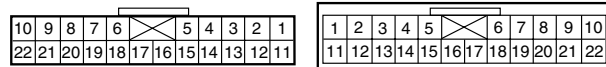

### ④ Component locations

- Schematic diagrams include references to images found in the "Component Locations" section of this document. These images show components and connectors in their installed location on the vehicle.

PHOTO 03

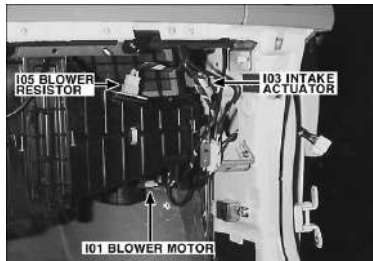

### ⑤ CONNECTOR VIEW AND NUMBERING ORDER

Female	Male	Remarks
		It is not the shape of the connector housing, but the connector pin that distinguishes between male or female connectors. When numbering female and male connectors, refer to the numbering order in the following table. Some connectors may not follow this method of numbering order. For individual detailed numbering, refer to the CONNECTOR CONFIGURATIONS.
		Numbered in order from upper right to lower left  Numbered in order from upper left to lower right

#### NOTE

UNLESS OTHERWISE STATED, ALL CONNECTOR VIEWS ARE FROM THE TERMINAL SIDE OF THE CONNECTOR.

# INTRODUCTION

## Introduction (4)

GI-4

### ⑥ WIRE COLOR ABBREVIATIONS

The following abbreviations are used to identify wire colors in the circuit schematics.

Symbol	Color of wire	Symbol	Color of wire
B	Black	O	Orange
Br	Brown	P	Pink
G	Green	R	Red
Gr	Gray	W	White
L	Blue	Y	Yellow
Lg	Light Green	Pp	Purple
T	Tan	LI	Light Blue

\* **(Y)/(B)**: Black stripe with yellow ground (2 colors)

↑                      ↑  
the color of        the color of  
background        stripe

### ⑦ HARNESS CLASSIFICATION

Electrical wiring connectors are classified according to the wiring parts in the Harness Layouts.

Symbol	Harness name	Location
C	Control, Control(DASH), Ignition coil, Injector harness	Engine compartment, Passenger compartment
D	Door harness	Door
E	Front, Battery harness	Engine compartment
F	Floor harness	Floor, Under crash pad and Floor
M	Main, Glove box EXT., Multimedia jack EXT. harness	Passenger compartment, Under crash pad and Floor
R	Roof, Trunk lid harness	Roof, Trunk lid
S	Seat harness	Seat

\* It depends on vehicles, it is necessary to check the harness name symbol on the harness layouts for detailed symbol.

### ⑧ CONNECTOR IDENTIFICATION

A connector identification symbol consists of a wiring harness location classification symbol corresponding to a wiring harness location and number corresponding to the connector. These connector locations can be found in the HARNESS LAYOUTS.

For example:

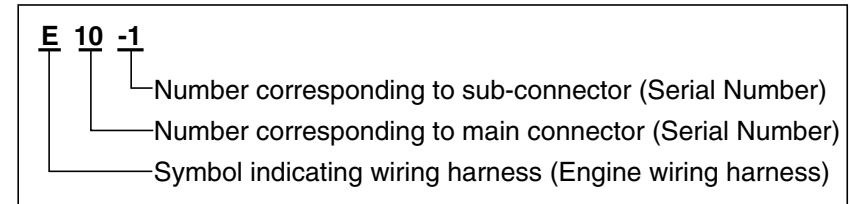

#### NOTE

**Connectors which connect each wiring harness are represented by the following symbols.**

For example:

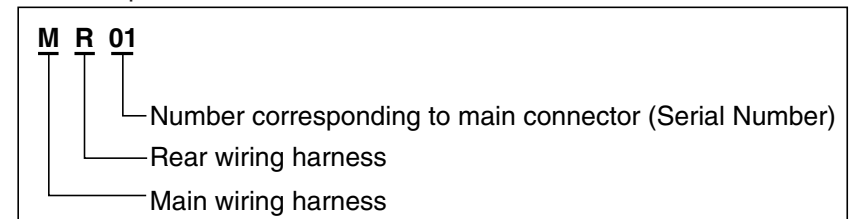

### JUNCTION BLOCK IDENTIFICATION

A junction block identification symbol consists of a wiring harness location classification symbol corresponding to a wiring harness location and number corresponding to the connector in the junction block.

For example:

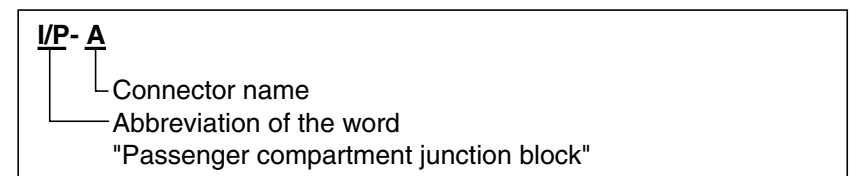



**HARNESS LAYOUTS**

Harness layouts show the routing of the major wiring harnesses, the in-line connectors and the splices between the major harnesses. These layouts will make electrical troubleshooting easier.

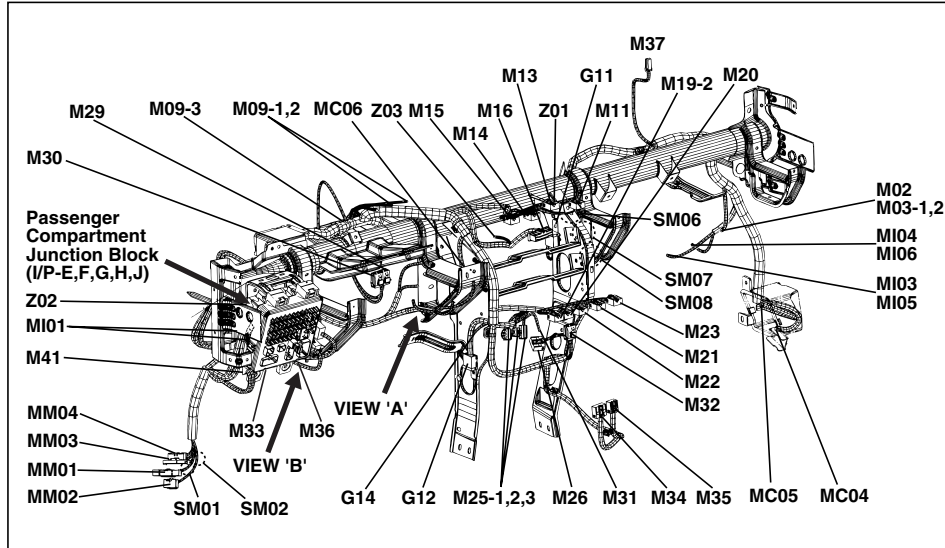









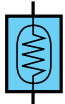
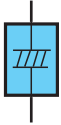

Symbols (1)

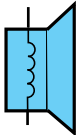
Section	Symbol	Meaning	Section	Symbol	Meaning	Section	Symbol	Meaning	Section	Symbol	Meaning
C O M P O N E N T		A solid line means the entire component is shown.	C O N N E C T O R		Shows the name of each connector on the component location index for reference. Indicates the number of corresponding terminal. (Only relevant terminal on the corresponding schematic diagram).	S H I E L D W I R E		This represents RFI (Radio Frequency Interference) Shielding around a wire. The shielding is always connected to ground.	L A M P		Double filament
		A broken line indicates only part of the component is shown.			The dashed-line means each of two wires connect with same connector(E35)			Single filament			
		This means the connector connects directly to the component.	W I R E		A wavy line means the circuit continues, but is not displayed.	J O I N T C O N N E C T O R		This is a connector showing the joining wires.	D I O D E		Diode
		This indicates the connector connects to a lead (pigtail), wired directly to the component.			Wire insulation is yellow with a red strip.			LED			
		This indicates a screw terminal on the component.	S P L I C E S		Current path is continued on the same page or another page. The arrow shows the direction of current flow. You should look for the "A" in the marked position.	S H O W B L O W F U S E		Power supplied Name Capacity	T R		NPN
		This ground symbol (dot and 3 lines overlapping the component) means the housing of the component is attached to a metal part of the vehicle.			A wire connects to another circuit. The wire is shown again on that circuit which the arrow is pointing.			PNP			
		This indicates a screw terminal on the component.	G R O U N D		Wire choices for options or different models are labeled and shown with a "choice" bracket like this.	F U S E		This box indicates the condition under which the circuit is powered. This means the short bar connects to other fuses. Identification Current rating	G E N E R A L C O M P O N E N T S Y M B O L		These switches move together: a dashed line shows a mechanical connection between them.
		The name of the component appears next to its upper right corner. Shows the picture identification number for component location.			Splices are numbered and shown as a dot with circle. The exact location and connection of these splices may vary among vehicles.			Switch (1 contact point)			
	The name of the component appears next to its upper right corner. Shows the picture identification number for component location.			This symbol means the end of the wire is attached to a metal part of the vehicle.	C O N N E C T O R P O W E R		Heater				

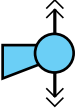
# SYMBOLS

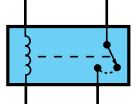
## Symbols (2)

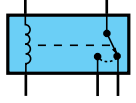
GI-7

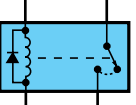
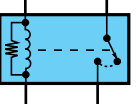
Section	Symbol	Meaning	Section	Symbol	Meaning
GENERAL COMPONENTS SYMBOL		Sensor	GENERAL COMPONENTS SYMBOL		Condenser
		Sender			Speaker
		Injector			Horn, Buzzer, Siren, Chime Bell
		Solenoid	RELAY		Normally open contact
		Motor			This is a relay shown with no current flowing through its coil. When a current flows through coil, contact will toggle.
		Battery			Diode interior relay
				Resistance interior relay	

## Troubleshooting Instructions (1)

GI-8

### TROUBLESHOOTING INSTRUCTIONS

#### TROUBLESHOOTING PROCEDURES

The following five-step troubleshooting procedure is recommended.

##### 1. Verify the customer's complaints

Turn on all the components in the problem circuit to check the accuracy of the customer's complaints. Note the symptoms. Do not begin disassembly or testing until you have narrowed down the probable causes.

##### 2. Read and analyze the schematic diagram

Locate the schematic for the problem circuit. Determine how the circuit is supposed to work by tracing the current paths from the power source through the system components to ground. If you do not understand how the circuit should work, read the circuit operation text. Also check other circuits that share with the problem circuit. The name of circuits that share the same fuse, ground, or switch, for example, are referred to on each diagram. Try to operate any shared circuits you did not check in step 1. If the shared circuit works, the shared wiring is okay, and the cause must be within the wiring used only by the problem circuit.

If several circuits fail at the same time, the fuse or ground is a likely cause.

##### 3. Inspect the circuit/ component with the problem isolated

Make a circuit test to check the diagnosis you made in step 2. Remember that a logical, simple procedure is the key to efficient troubleshooting. Narrow down the probable causes using the troubleshooting hints and system diagnosis charts.

Test for the most likely cause of failure first.

Test circuits by using the easiest point to access that will provide the most information.

##### 4. Repair the problem

Once the problem is found, make the necessary repairs.

##### 5. Verify the Repair

Repeat the system check to be sure you have repaired the problem. If the problem was a blown fuse, be sure to test all of the circuits on that fuse.

#### TROUBLESHOOTING EQUIPMENT

##### VOLTMETER AND TEST LAMP

Use a test lamp or a voltmeter on circuits without solid-state units and use a test lamp to check for voltage. A test lamp is made up of a 12-volt light bulb with a pair of leads attached. After grounding one lead, touch the other lead to various points along the circuit where voltage should be present. When the bulb goes on, there is voltage at the point being tested.

##### CAUTION

**A number of circuits include solid-state modules, such as the Engine Control Module (ECM), used with fuel injection.**

**Voltage in these circuits should be tested only with a 10-megaohm or higher impedance DVOM. Never use a test lamp on circuits that contain solid state modules. Damage to the modules may result.**

A voltmeter can be used in place of a test lamp. While a test lamp shows whether the voltage is present or not, a voltmeter indicates how much voltage is present.

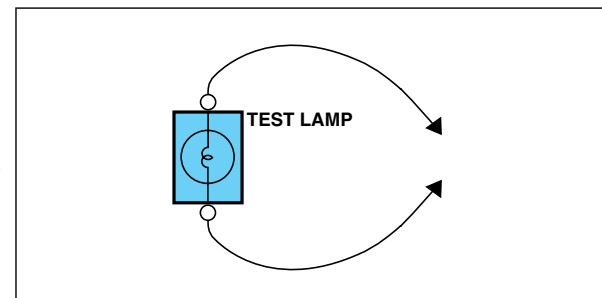

##### SELF-POWERED TEST LAMP AND OHMMETER

Use a self-powered test lamp or an ohmmeter to check for continuity. The ohmmeter shows how much resistance there is between two points along a circuit. Low resistance means good continuity.

## TROUBLESHOOTING INSTRUCTIONS

### Troubleshooting Instructions (2)

GI-9

#### CAUTION

**Never use a self-powered test lamp on circuits that contain solid state modules. Damage to these modules may result.**

An ohmmeter can be used in place of a self-powered test lamp. The ohmmeter shows how much resistance there is between two points along a circuit. Low resistance means good continuity.

Circuits which include any solid-state devices should be tested only with a 10-megaohm or higher impedance digital multimeter. When measuring resistance with a digital multimeter, the component being tested should be isolated from the circuit (component disconnected, power OFF). Otherwise, there may be incorrect readings. Diodes and solid-state devices in a circuit can make an ohmmeter give a false reading. To find out if a component is affecting a measurement, take one reading, reverse the leads and take a second reading. If different the solid-state device is affecting the measurement.

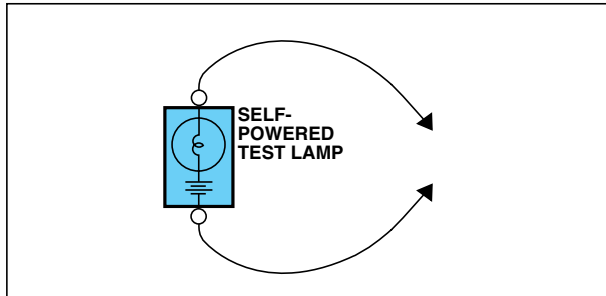

#### JUMPER WIRE WITH FUSE

Use a jumper wire with a fuse to by-pass an open circuit.

A jumper wire is made up of an in-line fuse holder connected to a set of test leads. This tool is available with small clamp connectors providing adaption to most connectors without damage.

#### CAUTION

**Do not use a fuse with a higher rating than the specified fuse that protects the circuit being tested. Do not use this tool in any situation to substitute an input or output at the solid-state control module, such as ECM, TCM, etc.**

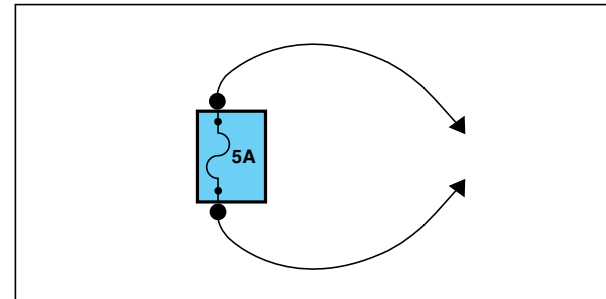

#### SHORT FINDER

A short finder is available to locate a short to ground. The short finder creates a pulsing magnetic field in the shorted circuit and shows you the location of the short through body trim or sheet metal.

#### TROUBLESHOOTING TEST

##### 1. TESTING FOR VOLTAGE

This test measures voltage in a circuit. When testing for voltage at a connector, you do not have to separate the two halves of the connector. Instead, probe the connector from the back(backprobe, or use a suitable T-connector). Always check both sides of the connector because dirt and corrosion between its contact surfaces can cause electrical problems.

- A. Connect one lead of a test lamp or voltmeter to a ground. If you are using a voltmeter, be sure it is the voltmeter's negative test lead you have connected to ground.
- B. Connect the other lead of the test lamp or voltmeter to a selected test point(connector or terminal).
- C. If the test lamp glows, there is voltage present. If you are using a voltmeter, note the voltage reading. A loss of more than 1 volt from specification indicates a problem.

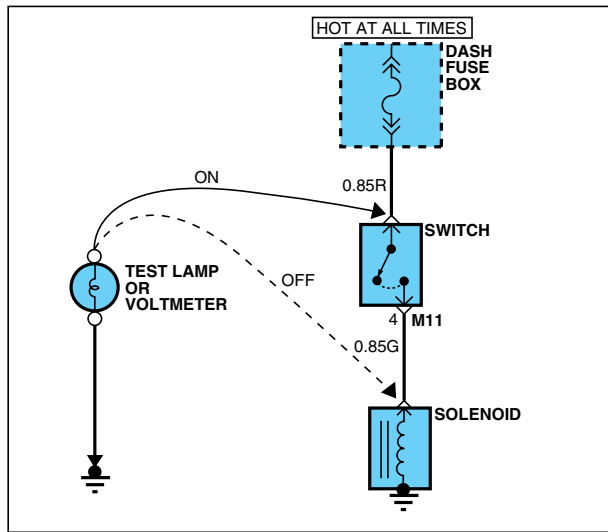

**2. TESTING FOR CONTINUITY**

- A. Disconnect the battery negative terminal.
- B. Connect one lead of a self-powered test lamp or ohmmeter to one end of the part of the circuit you wish to test. If you are using an ohmmeter, hold the leads together and adjust the ohmmeter to read zero ohms.
- C. Connect the other lead to the other end.
- D. If the self-power test lamp glows, there is continuity. If you are using an ohmmeter, low or zero resistance means good continuity.

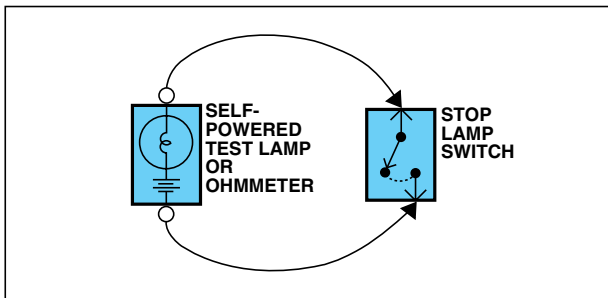

**3. TESTING FOR SHORT TO GROUND**

- A. Disconnect the battery negative terminal.
- B. Connect one lead of a self-powered test lamp or an ohmmeter to the fuse terminal on the load side.
- C. Connect the other lead to a ground.
- D. Beginning near the fuse block move the harness from side to side. Continue this procedure (about six inches apart) while watching the self-powered test lamp or ohmmeter.
- E. When the self-powered test lamp glows, or ohmmeter registers, there is a short to a ground in the wiring near that point.

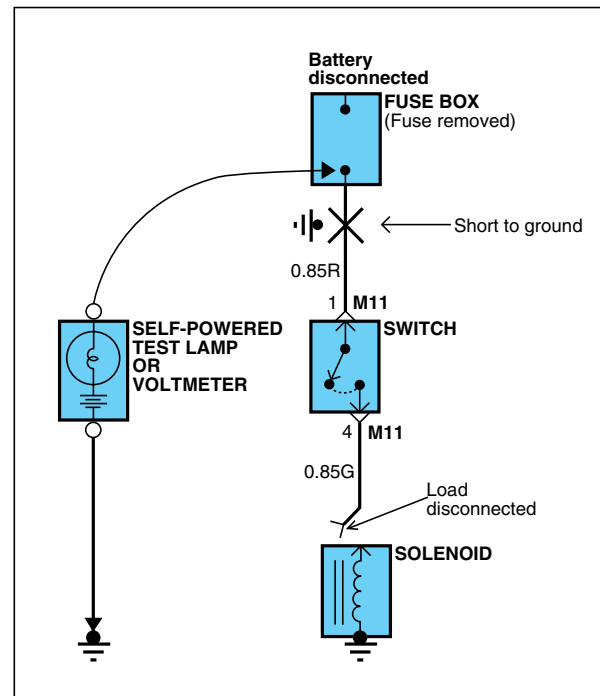

# TROUBLESHOOTING INSTRUCTIONS

## Troubleshooting Instructions (4)

GI-11

### 4. TESTING FOR A SHORT WITH A SHORT FINDER

- A. Remove the blown fuse. Leave the battery connected.
- B. Connect the short finder across the fuse terminals.
- C. Close all switches in series in the circuit that is being testing.
- D. Turn on the short circuit locator. It sends pulses of current to the short. This creates a pulsing magnetic field around the wiring between the fuse box and the short.
- E. Beginning at the fuse box, slowly move the short finder along the circuit wiring. The meter will show current pulses through sheet metal and body trim. As long as the meter is between the fuse and the short, the needle will move with each current pulse. Once the meter is moved past the point of the short, the needle will stop moving. Check around this area to locate the cause of the short circuit.

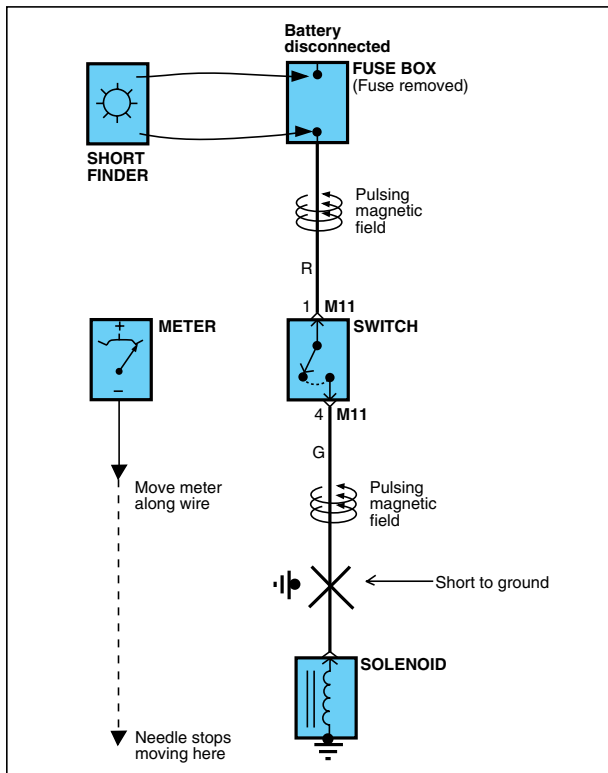

### 5. TESTING FOR VOLTAGE DROP

This test checks for voltage drop along a wire, or through a connection or switch.

- A. Connect the positive lead of a voltmeter to the end of the wire (or to the side of the connector or switch) closest to the battery.
- B. Connect the negative lead to the other end of the wire (or the other side of the connector or switch).
- C. Operate the circuit.
- D. The voltmeter will show the difference in voltage between the two points. A difference, or drop of more than 0.1 volts (50mV in 5V circuits), may indicate a problem. Check the circuit for loose or dirty connections.

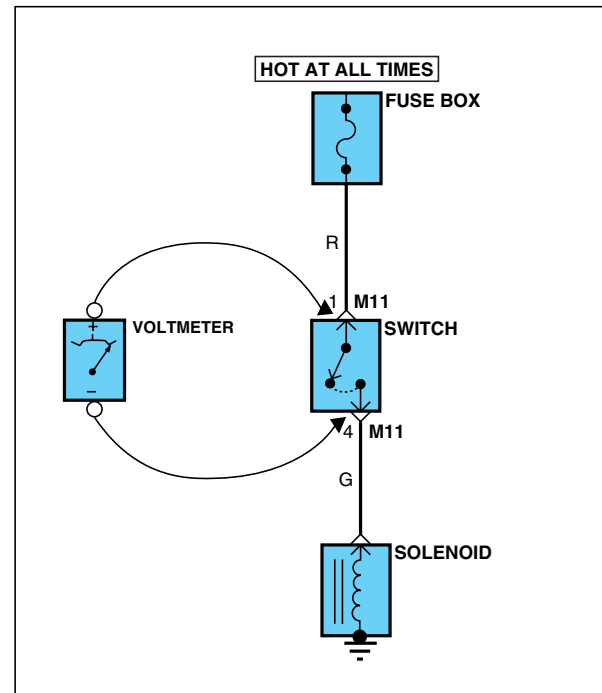

Fuse & Relay Information (1)

SD100-1

I/P JUNCTION BOX LAYOUT

< FRONT >

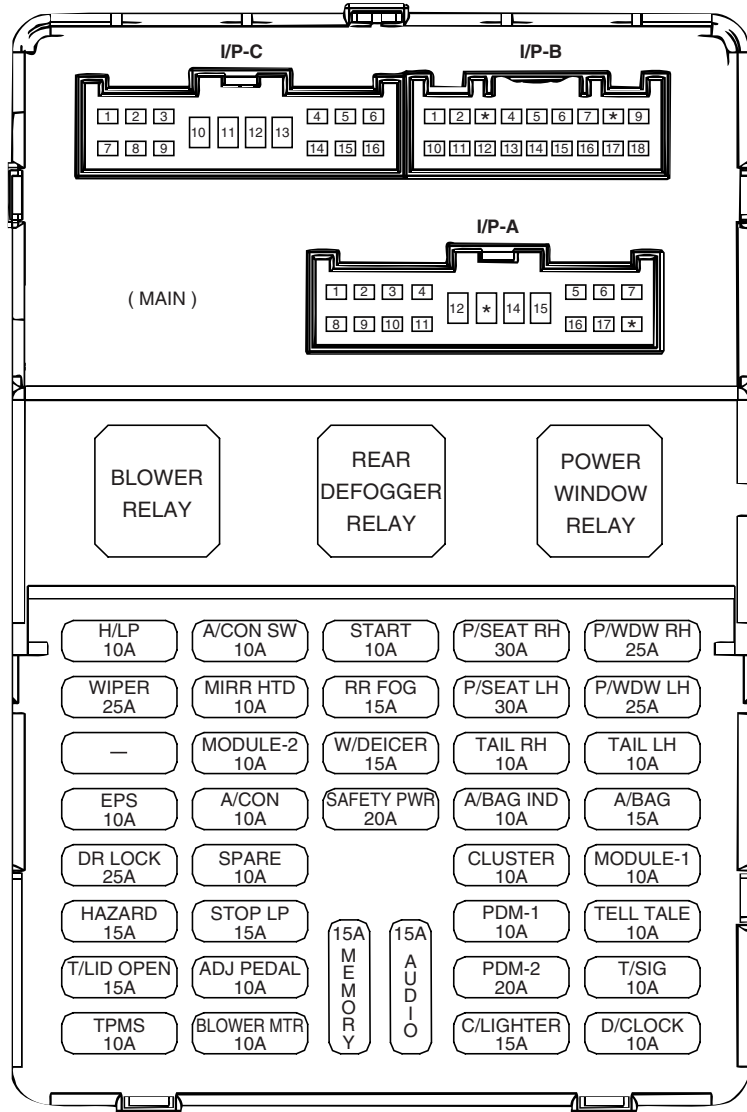

< REAR >

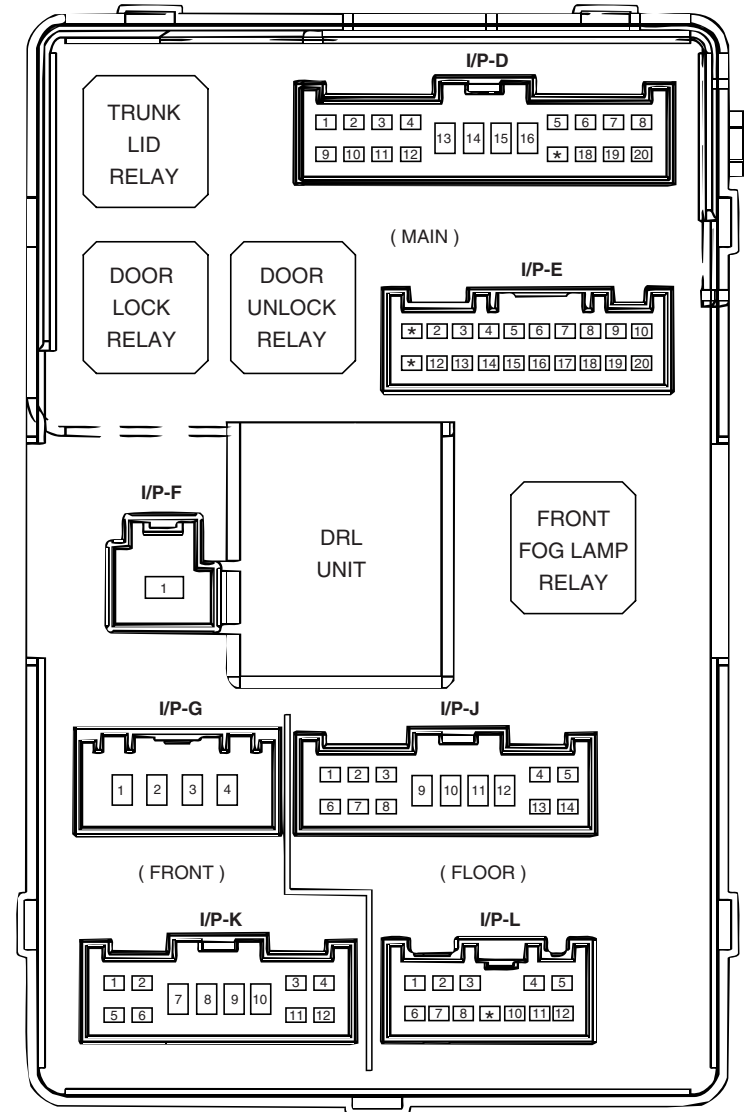

✘ USE THE DESIGNATED FUSE ONLY



## FUSE & RELAY INFORMATION

### Fuse & Relay Information (2)

SD100-2

#### CIRCUIT

FUSE	(A)	Circuit Protected
H/LP	10A	Head lamp relay, PTC heater relay(DSL), Fuel filter heater relay(DSL)
WIPER	25A	Wiper relay, Wiper motor, Multifunction switch
EPS	10A	PDM
DR LOCK	25A	Door lock/unlock relay, Dead lock relay
HAZARD	15A	Hazard switch, Hazard relay, Data link connector
T/LID OPEN	15A	Fuel filler door & Trunk lid switch
TPMS	10A	Smart key module, FOB holder
A/CON SW	10A	A/C control module, Blower motor
MIRR HTD	10A	Outside mirror, A/C control module
MODULE-2	10A	Sunroof, Rain sensor, BCM, Blower relay, Rheostat, Seat warmer, Electro chromic mirror Instrument cluster, Active incar sensor
A/CON	10A	A/C control module
SPARE	10A	-
STOP LP	15A	Stop lamp switch
ADJ PEDAL	10A	Sport mode switch, Key solenoid
BLOWER MTR	10A	A/C control module
START	10A	Burglar alarm relay, Transaxle range switch
RR FOG	15A	Rear fog lamp relay
W/DEICER	15A	Windshield defogger relay
SAFETY PWR	20A	Safety window motor
P/SEAT RH	30A	Passenger seat manual switch
P/SEAT LH	30A	Driver seat manual switch

FUSE	(A)	Circuit Protected	
TAIL RH	10A	Head lamp RH, Rear combination lamp RH, License lamp RH, Illuminations	
A/BAG IND	10A	Instrument cluster(Air bag IND.)	
CLUSTER	10A	Instrument cluster(IND.), BCM, PDM, Pre-excitation resistor(DSL)	
PDM-1	10A	PDM, Start stop button switch	
PDM-2	20A	PDM	
C/LIGHTER	15A	Cigarette lighter, Smart key module	
P/WDW RH	25A	Driver power window switch, Power window switch RH	
P/WDW LH	25A	Driver power window switch, Safety window motor	
TAIL LH	10A	Head lamp LH, Rear combination lamp LH, License lamp LH,	
A/BAG	15A	SRS control module, PAB cut off switch, Digital clock, PAB display	
MODULE-1	10A	Multifunction switch, ESP switch Rear parking assist buzzer, Steering angle sensor	
TELL TALE	10A	-	
T/SIG	10A	Hazard switch	
D/CLOCK	10A	Power outside mirror switch, Audio, PDM, Digital clock, BCM	
POWER CONNECTOR	MEMORY	15A	Key illumination switch, Digital clock, Room lamp, BCM, Power outside mirror switch, RF receiver, Instrument cluster, Overhead console, A/C control module
	AUDIO	15A	Audio

※ USE THE DESIGNATED FUSE ONLY

# FUSE & RELAY INFORMATION

## Fuse & Relay Information (3)

SD100-3

### E/R JUNCTION BOX LAYOUT

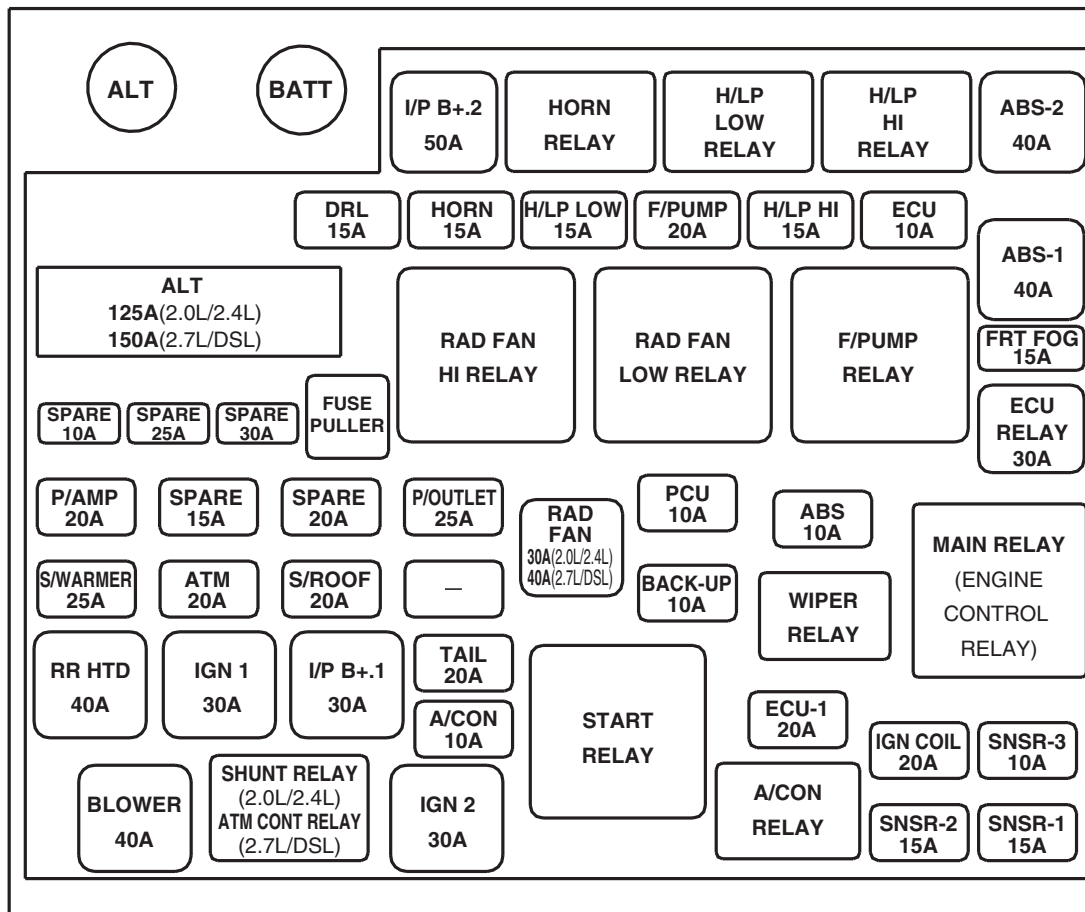

※ USE THE DESIGNATED FUSE ONLY

## FUSE & RELAY INFORMATION

### Fuse & Relay Information (4)

SD100-4

#### CIRCUIT

	Description	(A)	Circuit Protected
FUSIBLE LINK	ALT	125A(2.0L/2.4L) 150A(2.7L/DSL)	Generator
	I/P B+.2	50A	I/P Junction box(Hot at all times)
	ABS-2	40A	ABS/ESP control module
	ABS-1	40A	ABS/ESP control module, Multipurpose check connector
	BLOWER	40A	Blower relay
	RR HTD	40A	Rear defogger relay
	IGN 1	30A	Ignition switch(ACC, IG1), Button relay box(ACC, IG1)
	RAD FAN	30A(2.0L/2.4L) 40A(2.7L/DSL)	Radiator fan relay
	ECU RELAY	30A	Engine control relay
	IGN 2	30A	Ignition switch(IG2, START), Start relay, Button relay box(IG2)
FUSE	I/P B+.1	30A	I/P Junction box(Hot at all times)
	S/WARMER	25A	Seat warmer relay
	P/OUTLET	25A	Front Power outlet, Front acc socket
	ATM	20A	ATM control relay(2.7L/DSL), Shunt relay(2.0L/2.4L)
	S/ROOF	20A	Sunroof control module
	P/AMP	20A	Audio amp
	F/PUMP	20A	Fuel pump relay
	IGN COIL	20A	Ignition coil(GSL), Condenser(GSL)
	ECU-1	20A	PCM(2.0L/2.4L/DSL)
	TAIL	20A	Tail lamp relay
	FRT FOG	15A	Front fog lamp relay
	DRL	15A	DRL control module
	HORN	15A	Horn relay, Burglar horn relay
	H/LP LOW	15A	Head lamp relay(Low)
	H/LP HI	15A	Head lamp relay(High)
	SNSR-1	15A	Immobilizer control module, Camshaft position sensor, Variable intake manifold valve Mass air flow sensor, Oil control valve, Canister purge solenoid valve, PCM(2.7L)
	SNSR-2	15A	Fuel pump relay, Oxygen sensor(GSL), EGR actuator(DSL)
	SNSR-3	10A	A/C relay, Injector(GSL), Lambda sensor(DSL), VGT actuator(DSL), Stop lamp(DSL)
	ECU	10A	TCM(DSL), Generator(DSL), PCM(GSL)
	PCU	10A	Pulse generator, TCM, Radiator fan relay, PCM
	ABS	10A	ABS/ESP control module, Multipurpose check connector
	BACK-UP	10A	Vehicle speed sensor, Stop lamp switch, Back-up lamp switch, Transaxle range switch
	A/CON	10A	A/C relay

**※ USE THE DESIGNATED FUSE ONLY**

# FUSE & RELAY INFORMATION

## Fuse & Relay Information (5)

SD100-5

### ICM RELAY BOX

#### LAYOUT

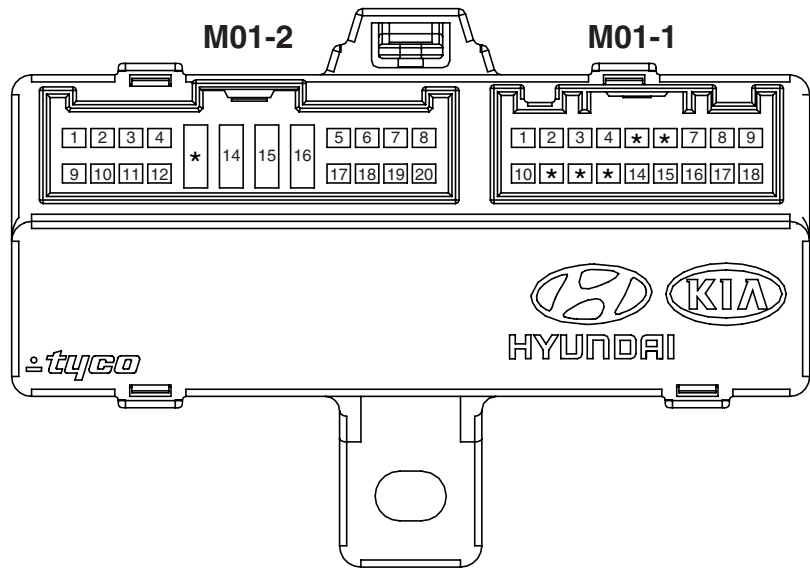
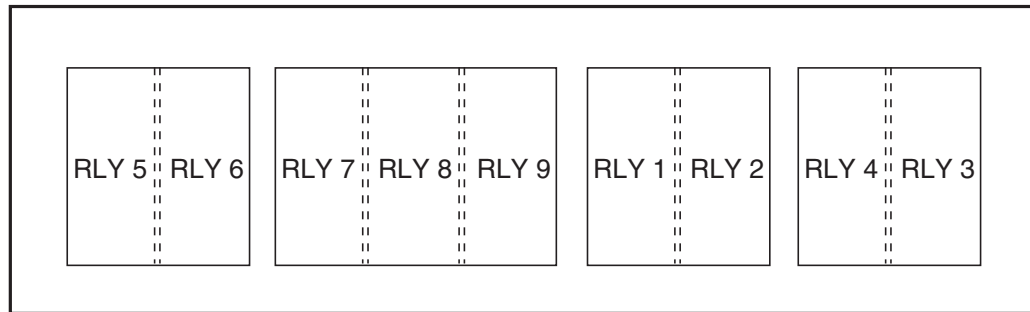

RELAY NO	RELAY NAME
1	WIPER DEICER (Windshield Defogger Relay)
2	SEAT WARMER (Seat Warmer Relay)
3	ADJ PEDAL (Not Used)
4	HI SPEED (Rain Sensor Relay)
5	DEAD LOCK (Dead Lock Relay)
6	RR FOG (Rear Fog Lamp Relay)
7	HAZARD (Hazard Relay)
8	B/HORN (Burglar Horn Relay)
9	B/ALARM (Burglar Alarm Relay)

# FUSE & RELAY INFORMATION

## Fuse & Relay Information (6)

SD100-6

### FUSIBLE LINK BOX (DSL)

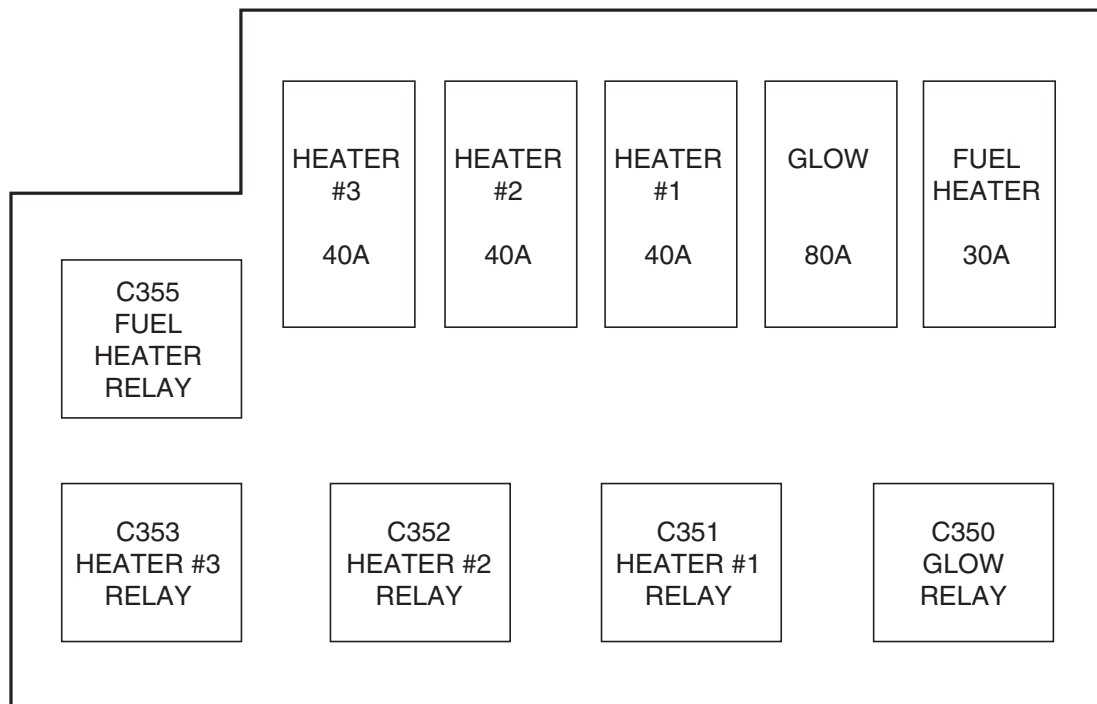

FUSIBLE LINK	(A)	Circuit Protected
FUEL HEATER	30A	Fuel filter heater relay
GLOW	80A	Glow plug relay
HEATER #1	40A	PTC heater relay #1
HEATER #2	40A	PTC heater relay #2
HEATER #3	40A	PTC heater relay #3

※ USE THE DESIGNATED FUSE ONLY

**POWER DISTRIBUTION**

E1186B83

**Power Distribution (1)**

**SD110-1**

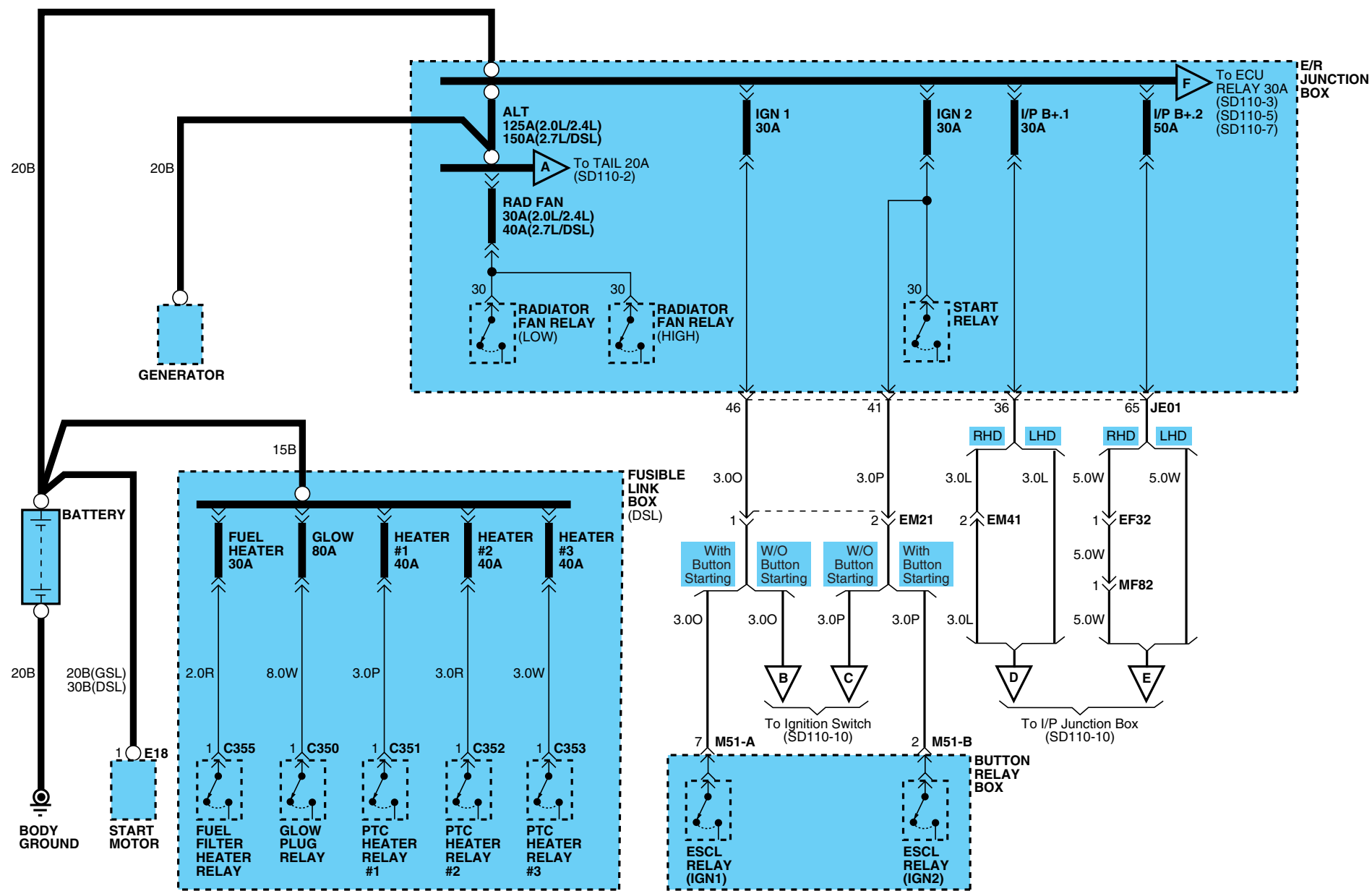

# POWER DISTRIBUTION

## Power Distribution (2)

SD110-2

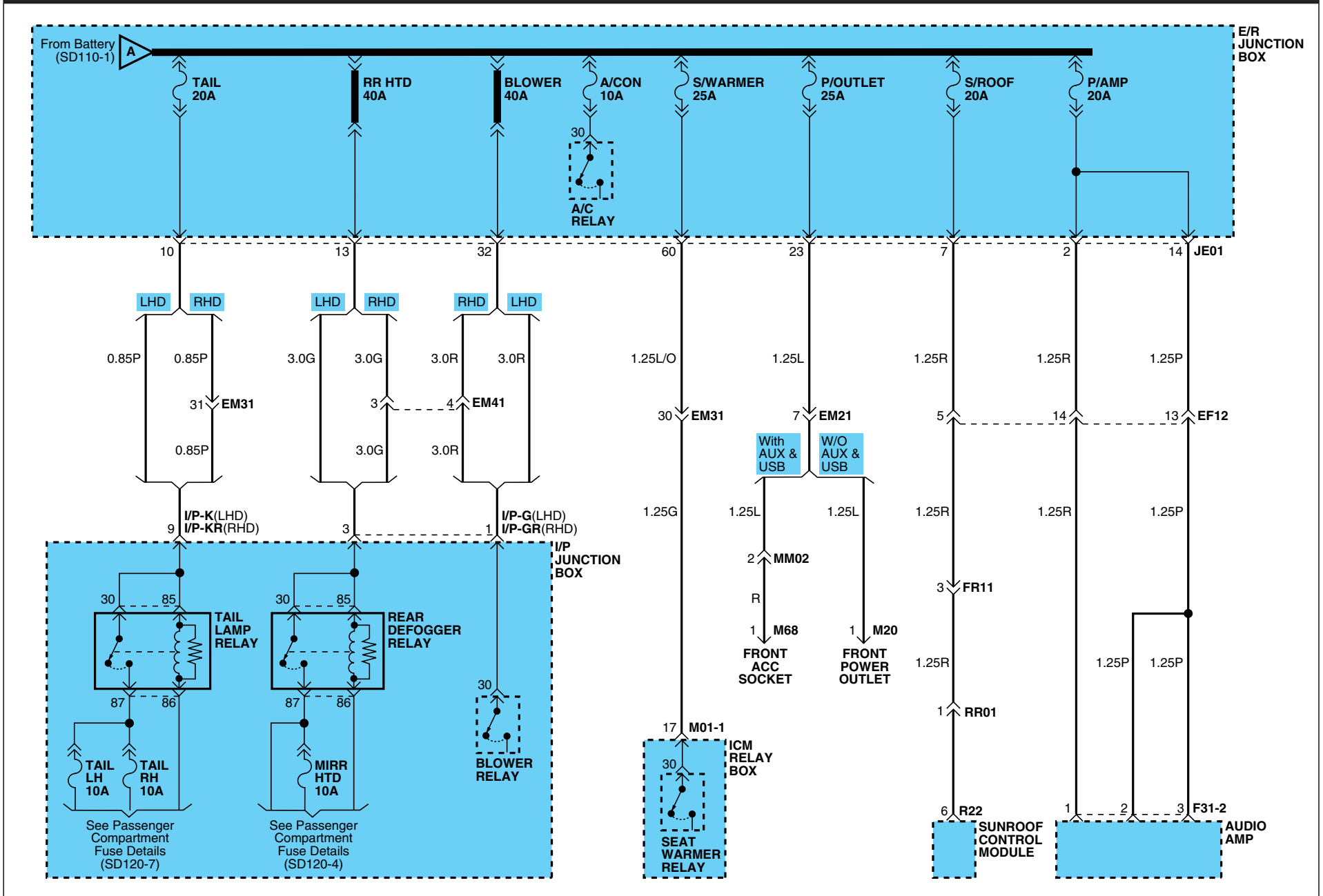

# POWER DISTRIBUTION

## Power Distribution (3)

SD110-3

2.0L/2.4L

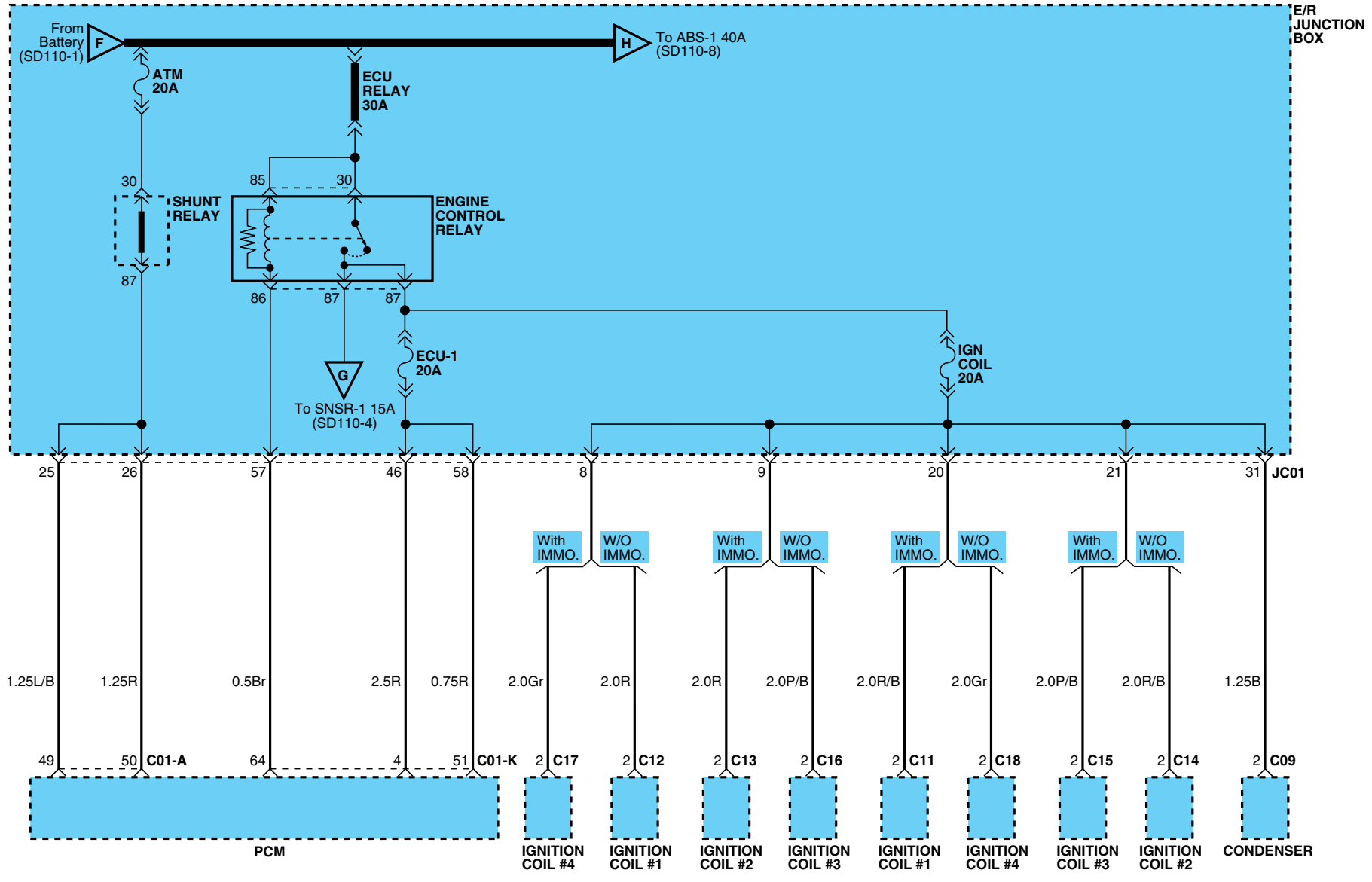



# POWER DISTRIBUTION

## Power Distribution (4)

SD110-4

2.0L/2.4L

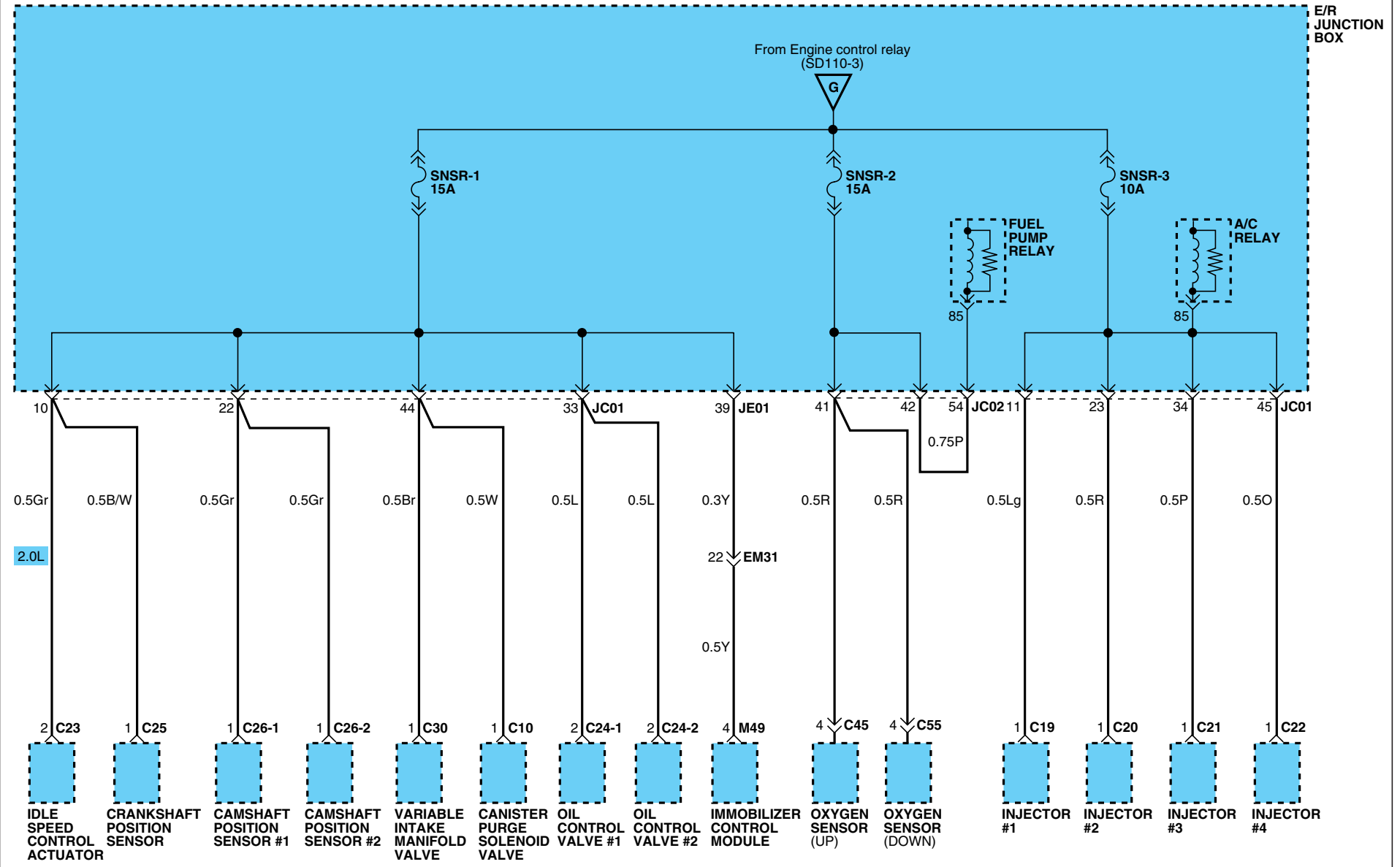

**POWER DISTRIBUTION**

**Power Distribution (5)**

**SD110-5**

**2.7L**

**E/R JUNCTION BOX**

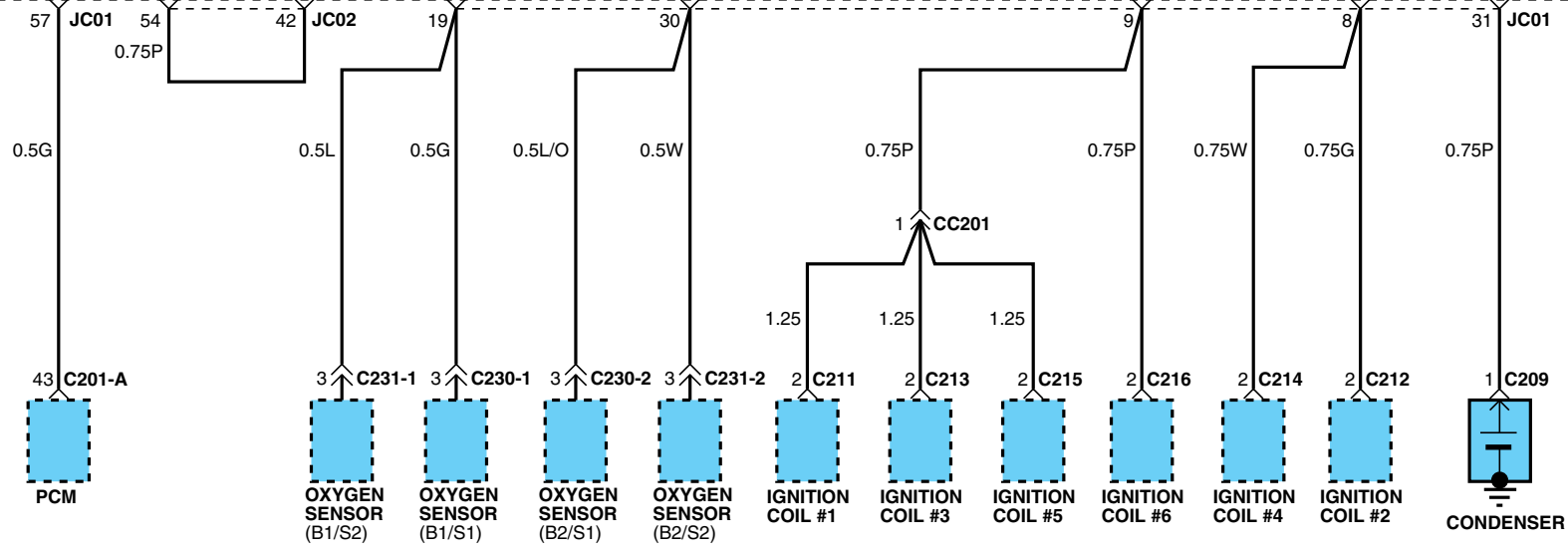
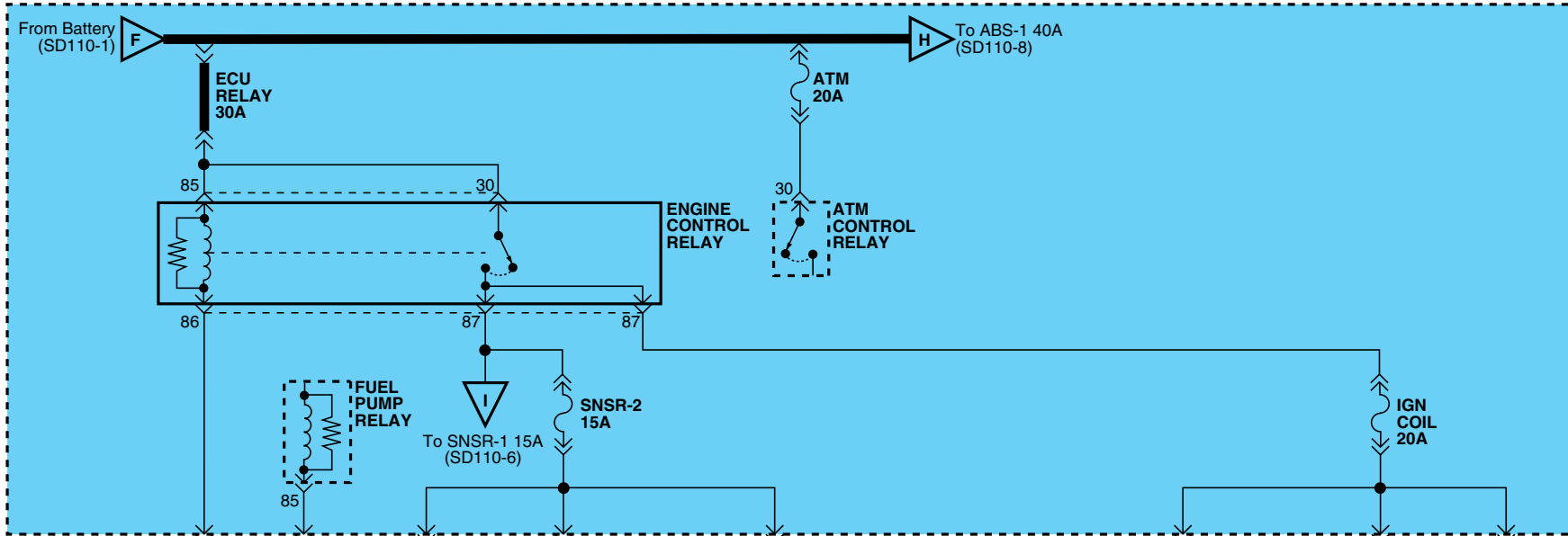

# POWER DISTRIBUTION

## Power Distribution (6)

SD110-6

### 2.7L

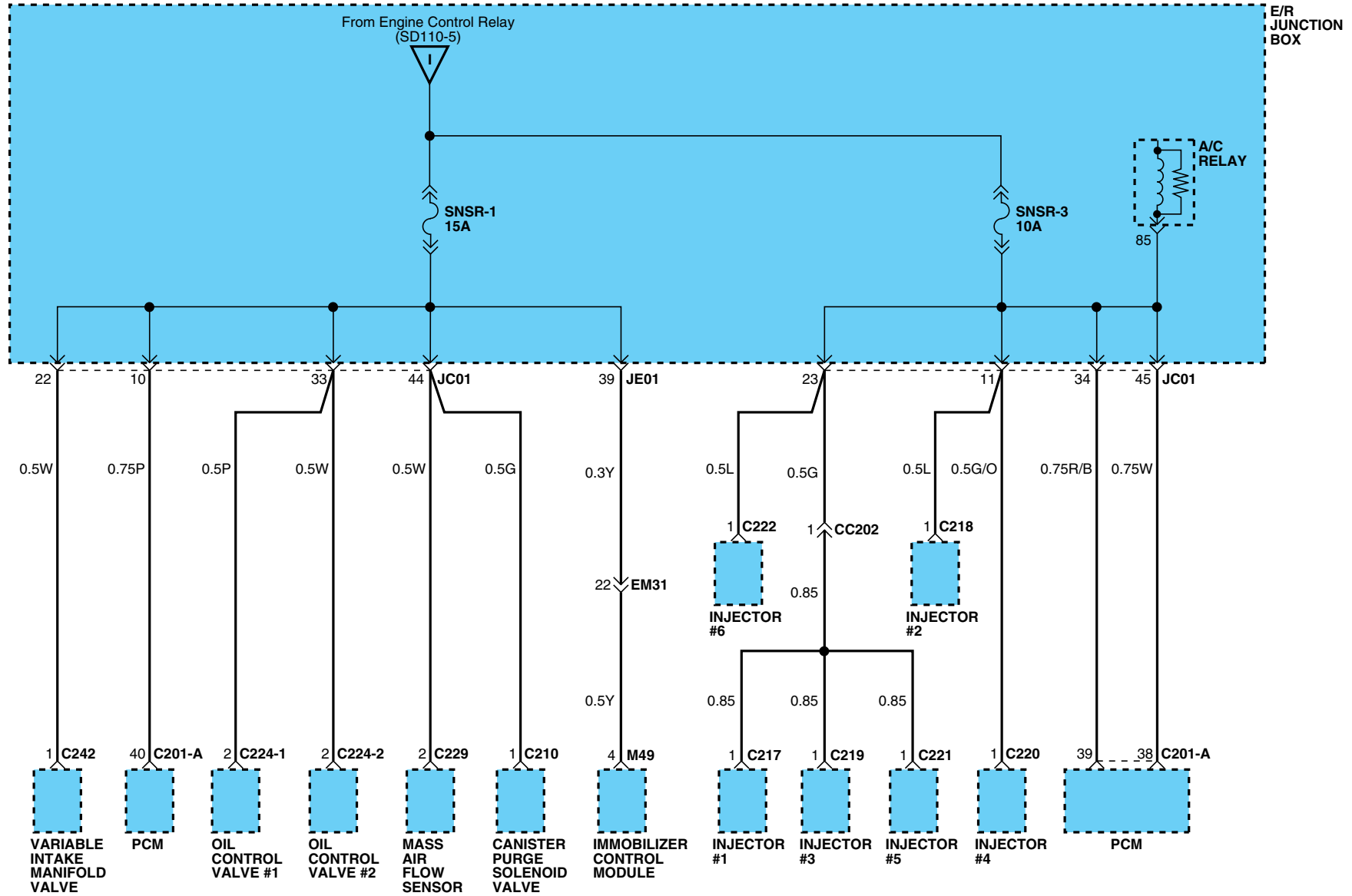

# POWER DISTRIBUTION

## Power Distribution (7)

SD110-7

DSL

E/R JUNCTION BOX

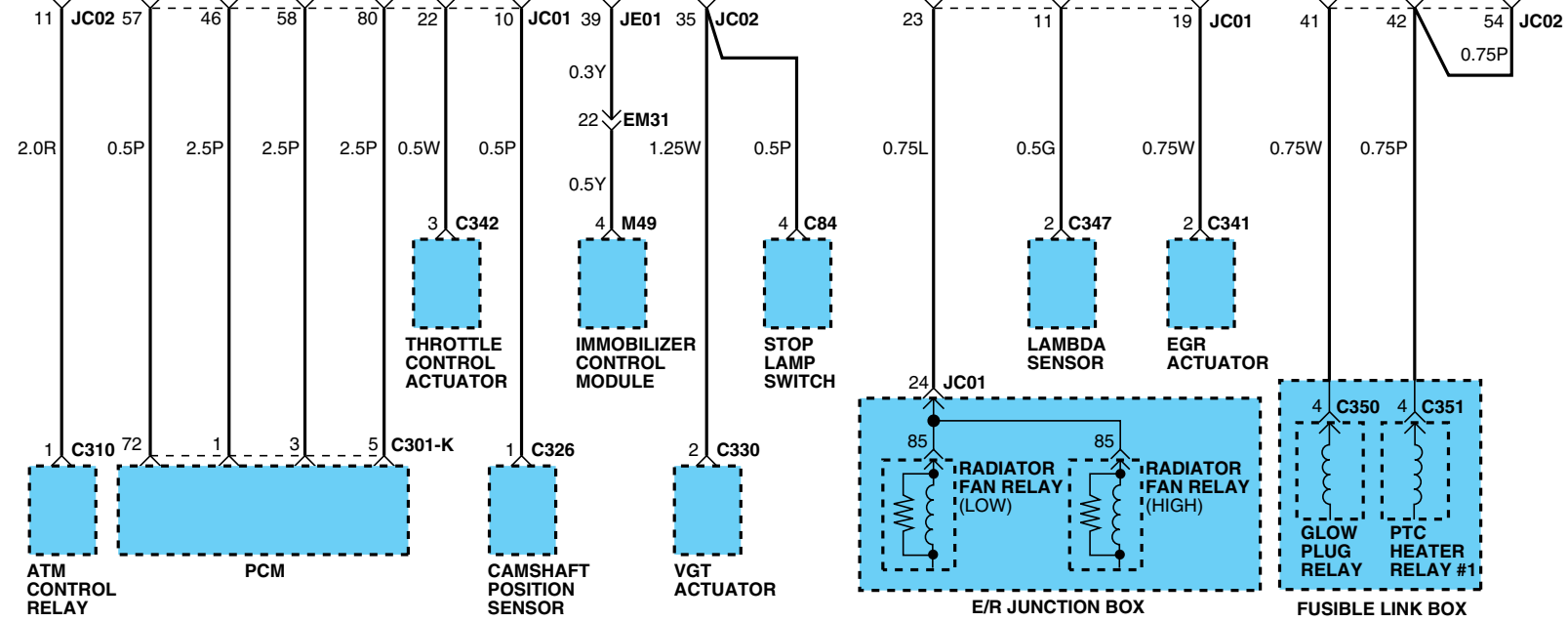
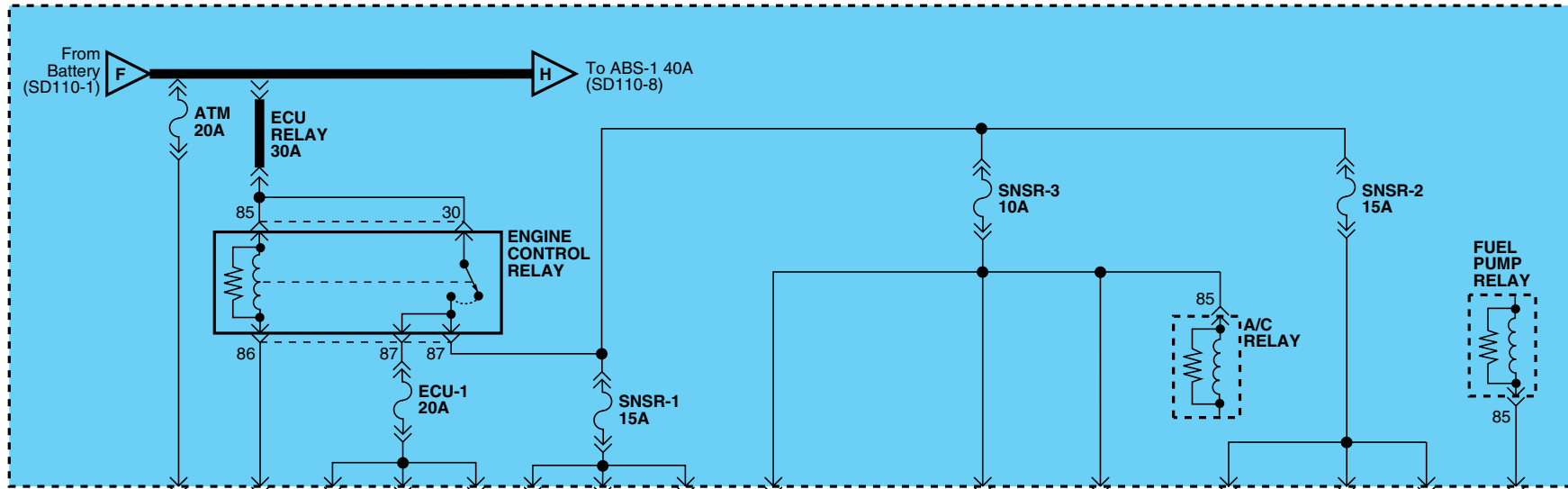

# POWER DISTRIBUTION

## Power Distribution (8)

SD110-8

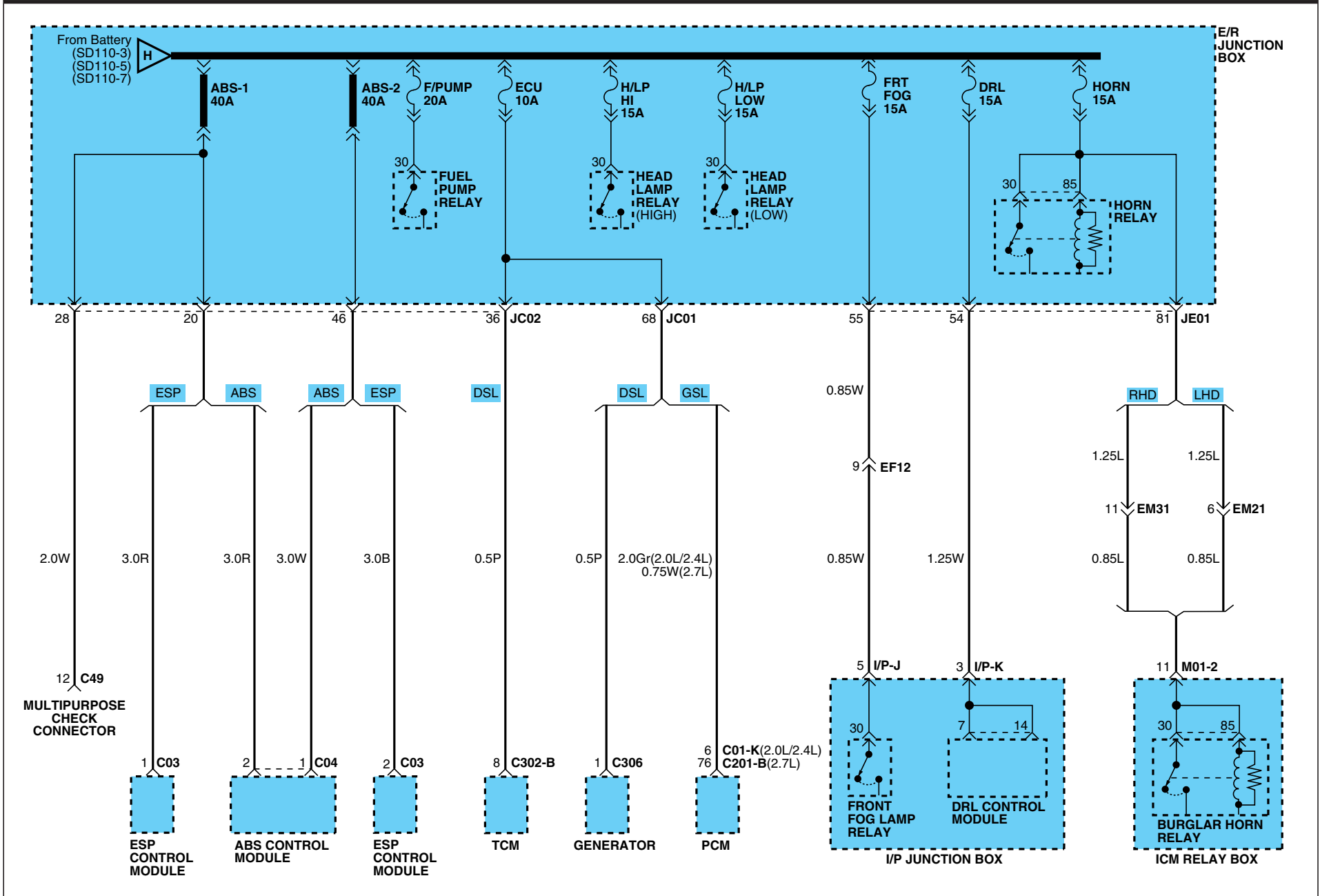

# POWER DISTRIBUTION

## Power Distribution (9)

SD110-9

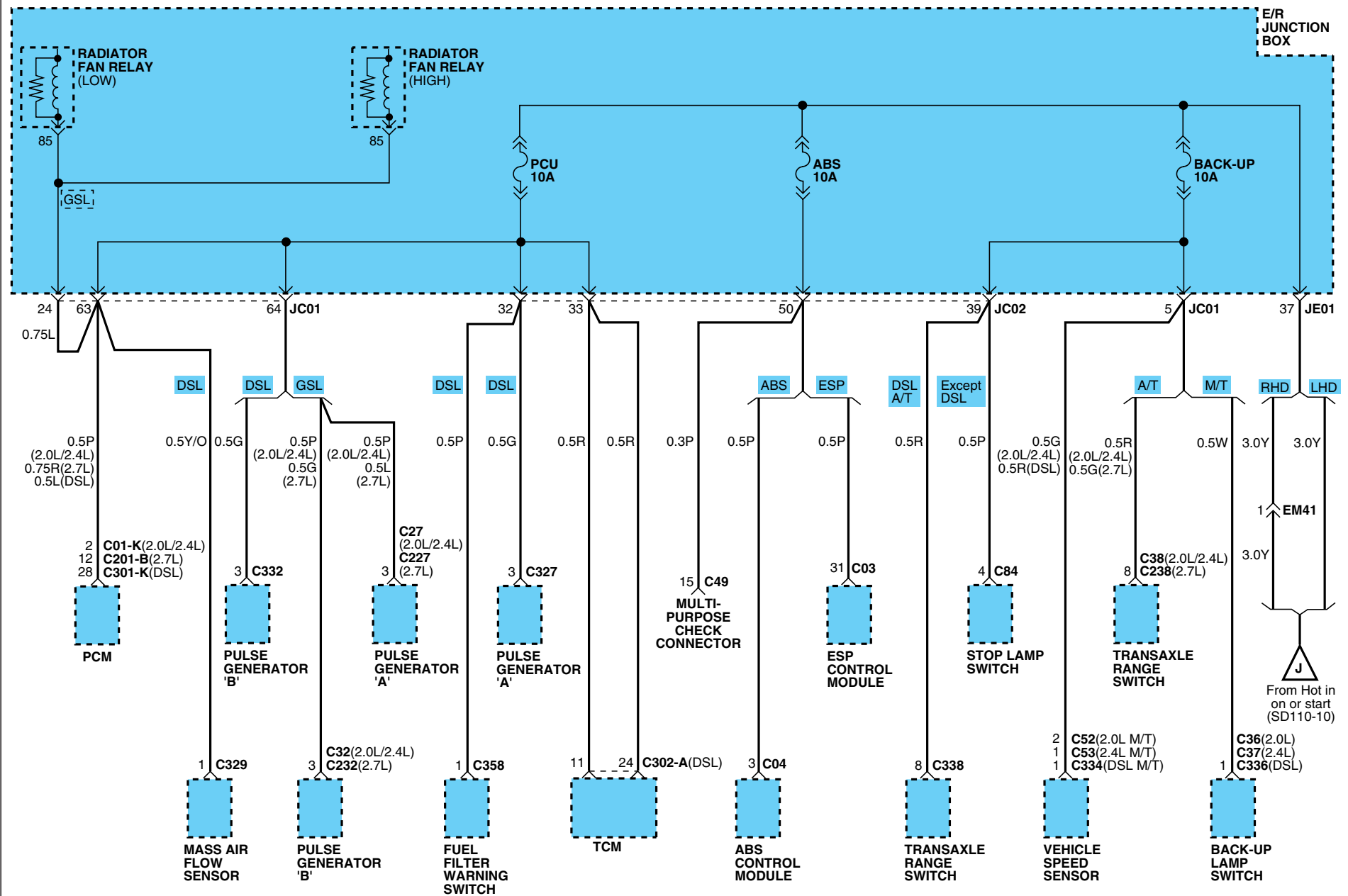

# POWER DISTRIBUTION

## Power Distribution (10)

SD110-10

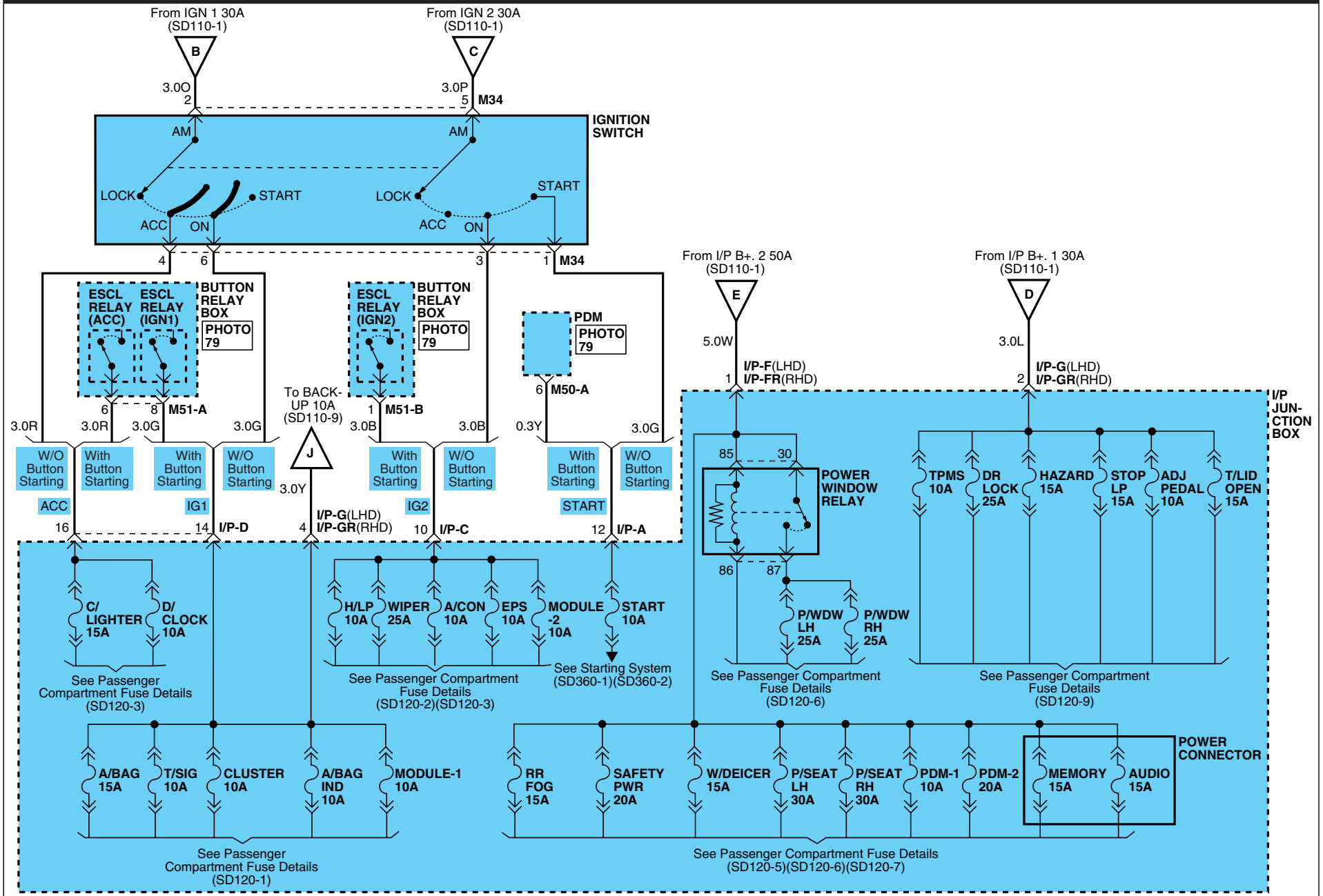

PASSENGER COMPARTMENT FUSE DETAILS ECE534C9

Passenger Compartment Fuse Details (1)

SD120-1

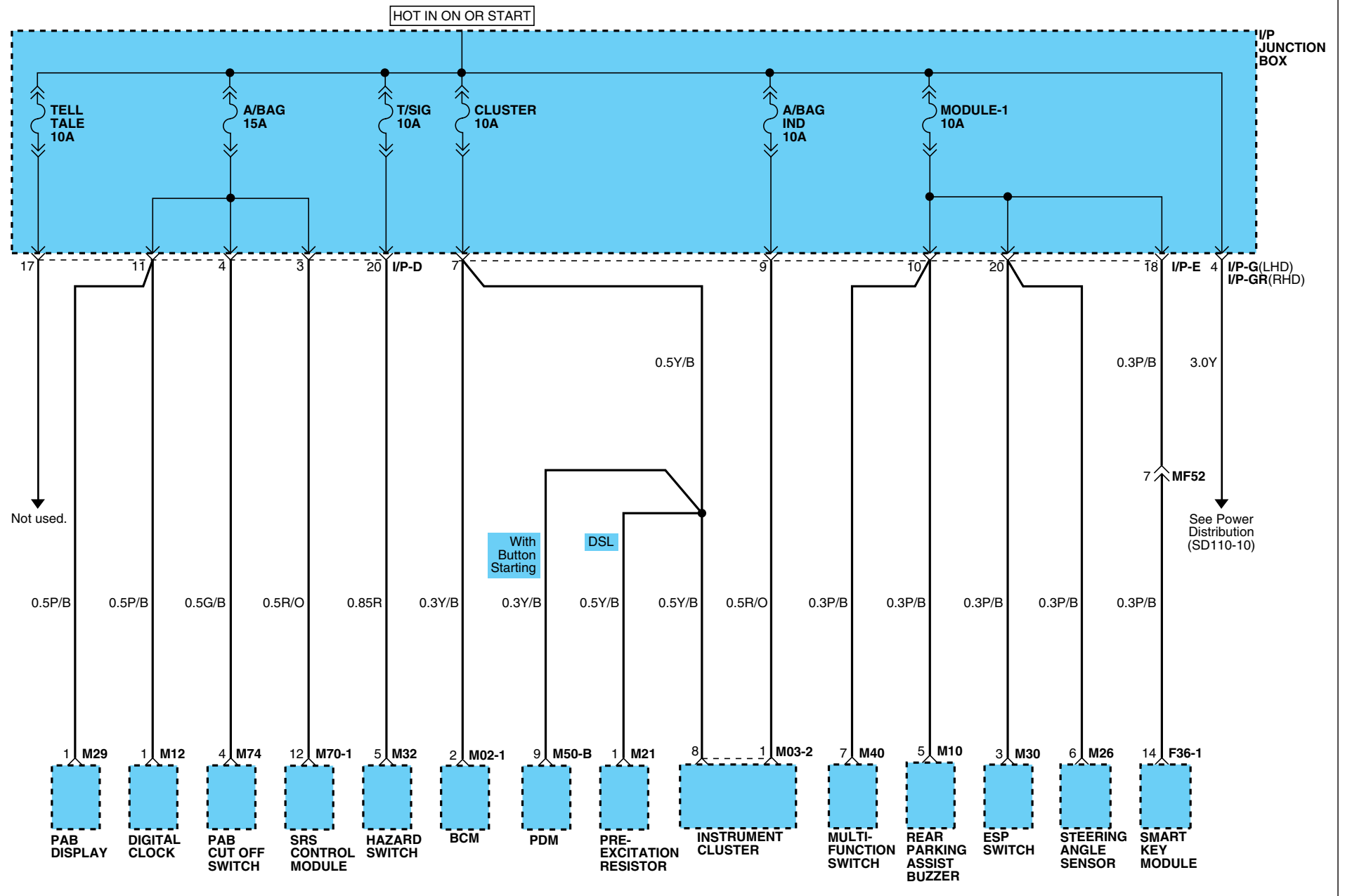



# PASSENGER COMPARTMENT FUSE DETAILS

## Passenger Compartment Fuse Details (2)

SD120-2

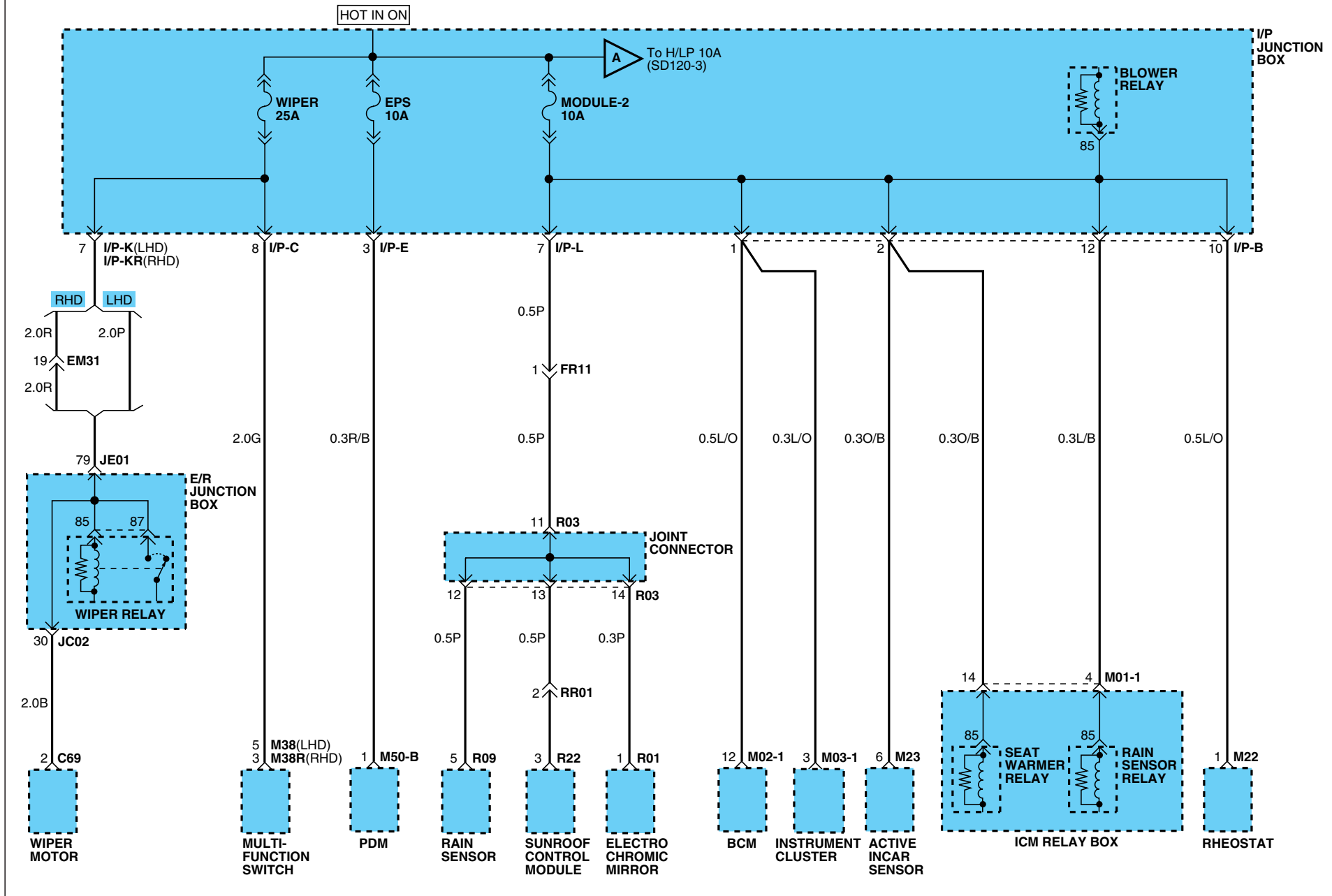

# PASSENGER COMPARTMENT FUSE DETAILS

## Passenger Compartment Fuse Details (3)

SD120-3

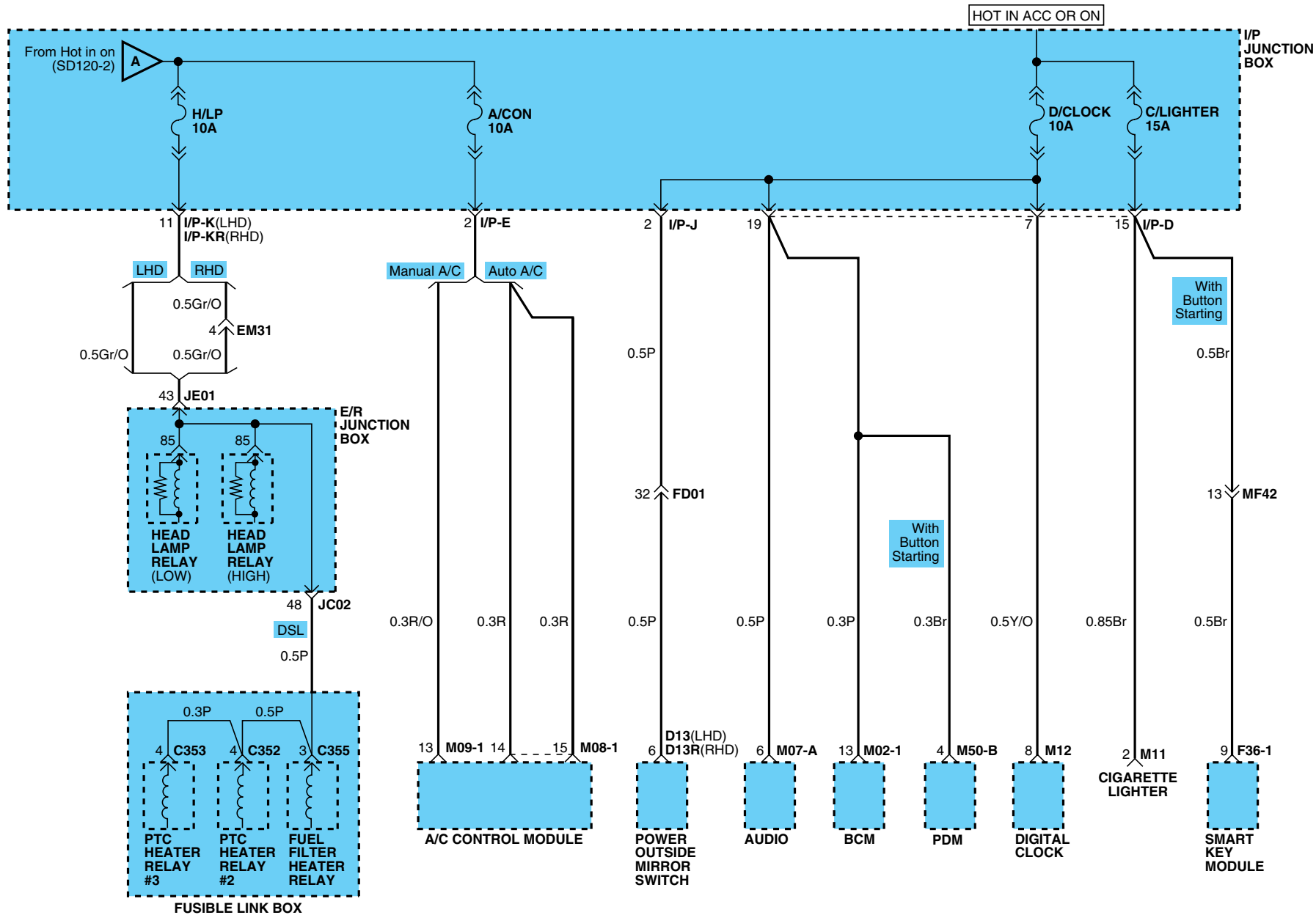

# PASSENGER COMPARTMENT FUSE DETAILS

## Passenger Compartment Fuse Details (4)

SD120-4

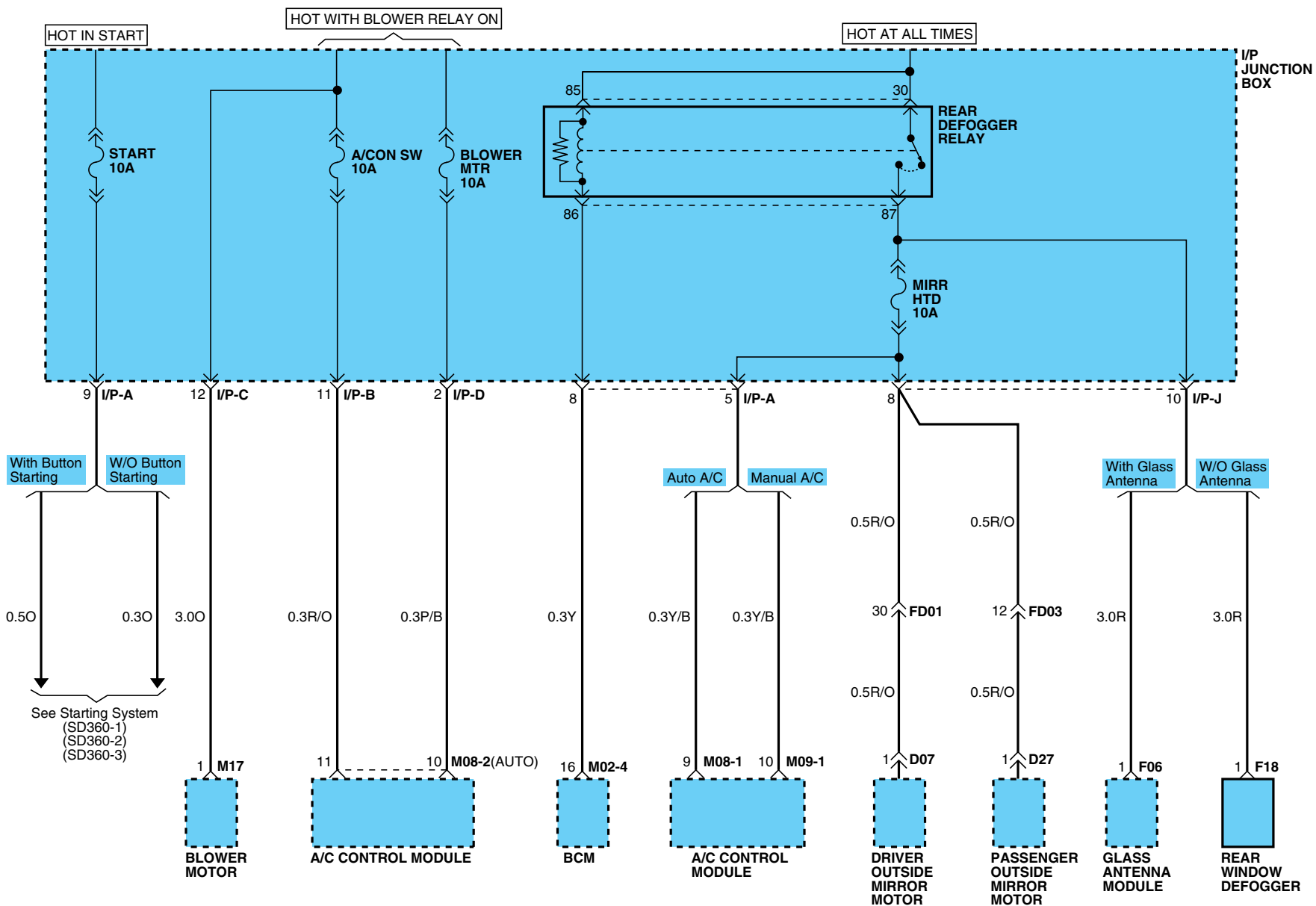

# PASSENGER COMPARTMENT FUSE DETAILS

## Passenger Compartment Fuse Details (5)

SD120-5

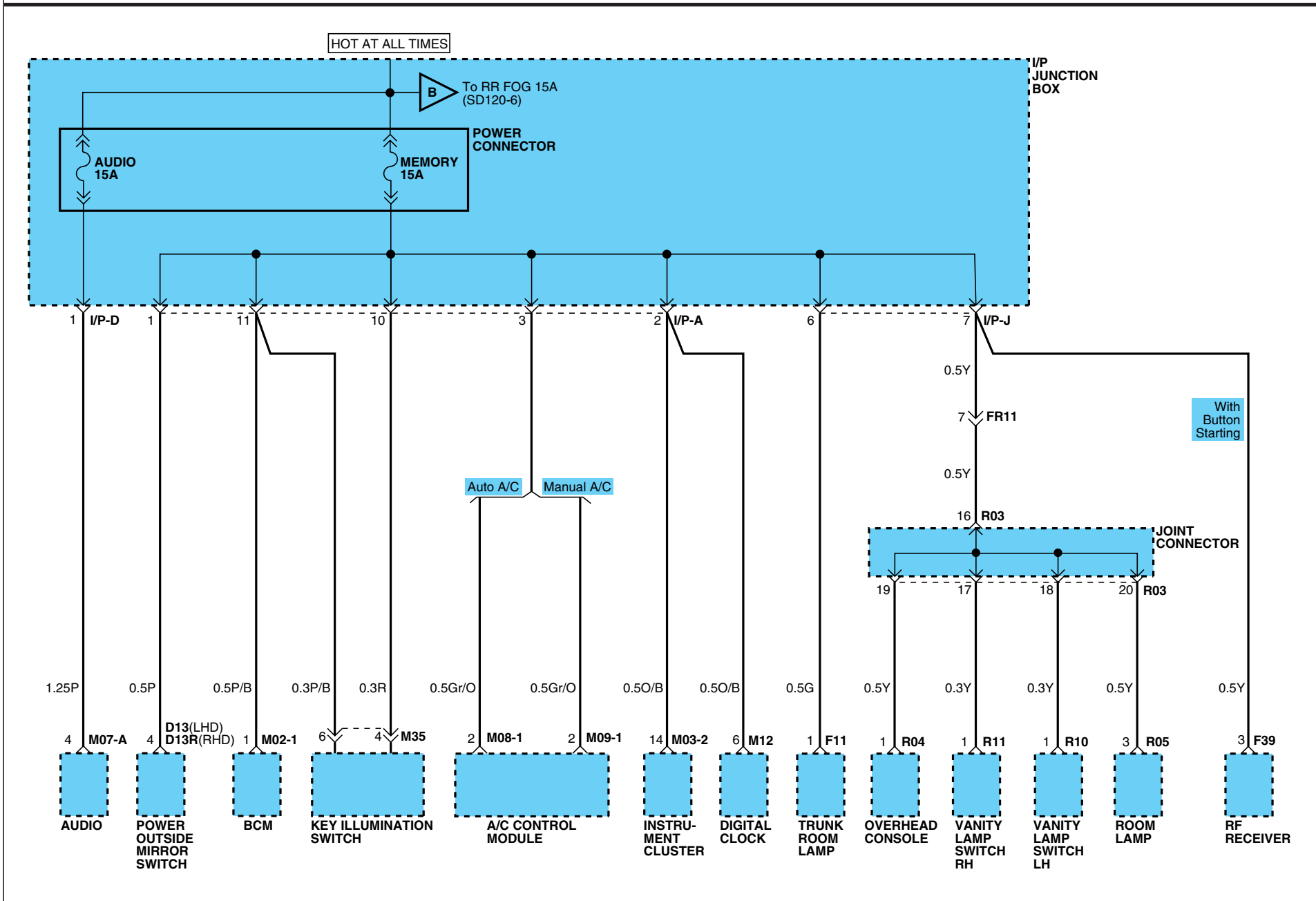

# PASSENGER COMPARTMENT FUSE DETAILS

## Passenger Compartment Fuse Details (6)

SD120-6

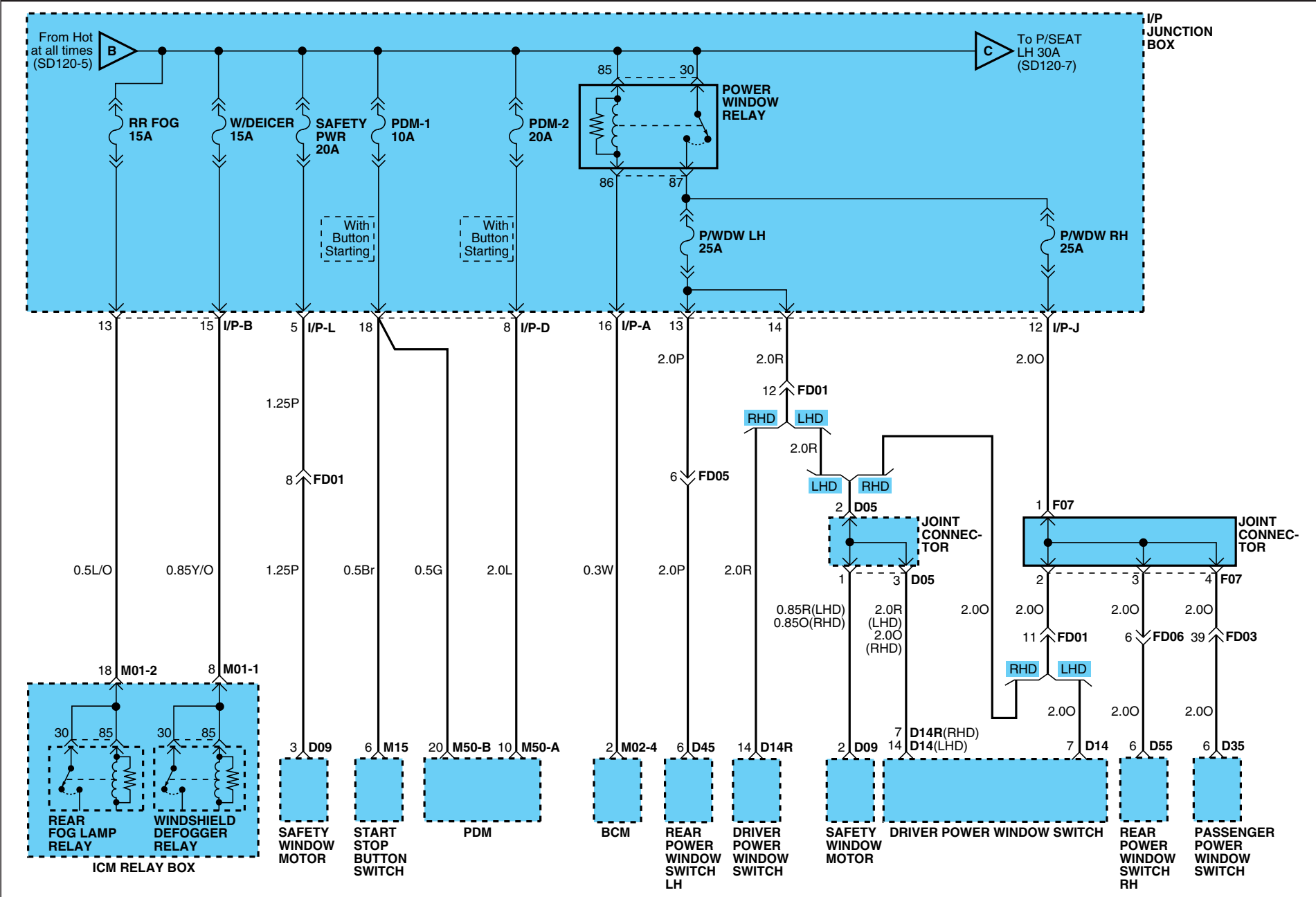

# PASSENGER COMPARTMENT FUSE DETAILS

## Passenger Compartment Fuse Details (7)

SD120-7

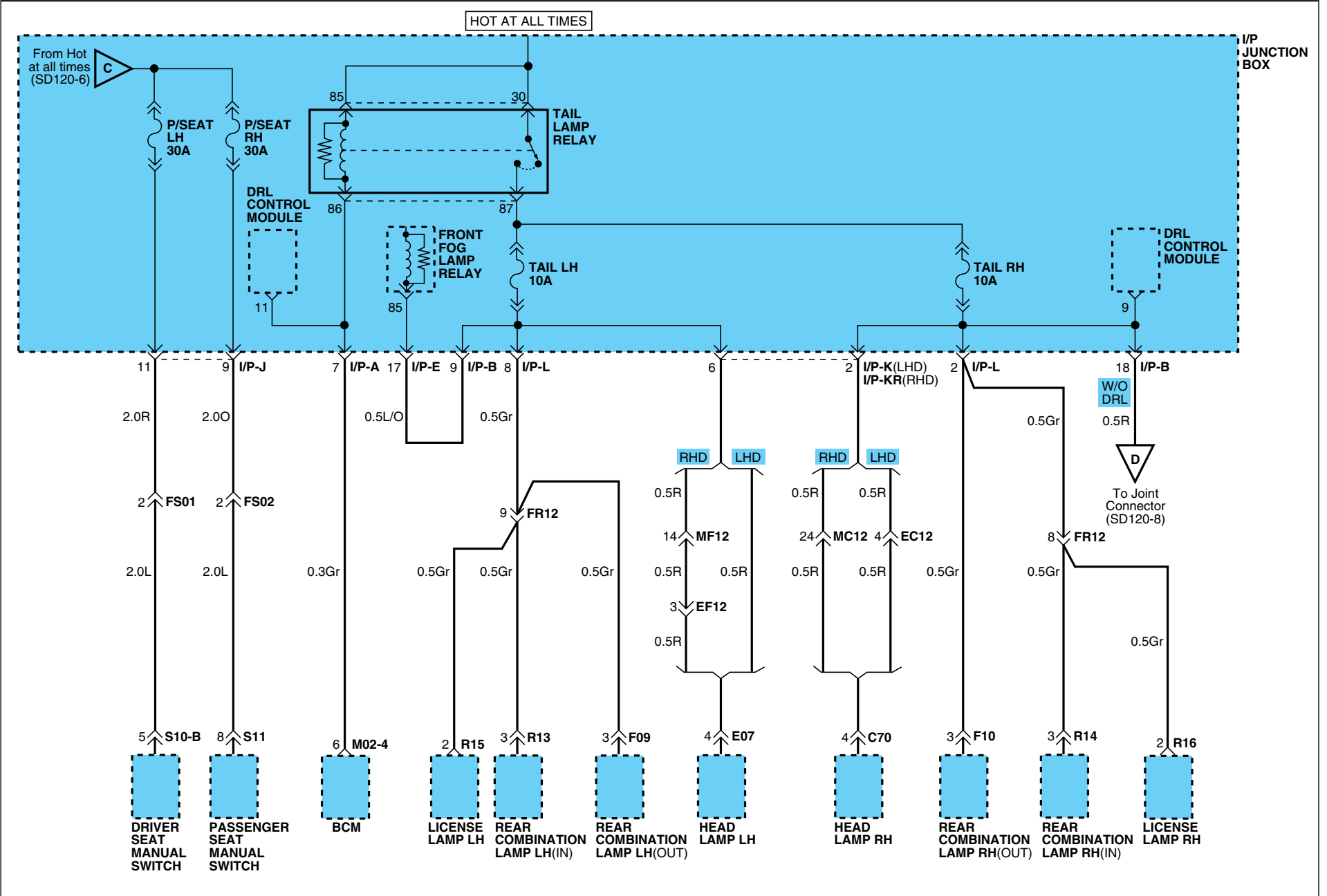

# PASSENGER COMPARTMENT FUSE DETAILS

## Passenger Compartment Fuse Details (8)

SD120-8

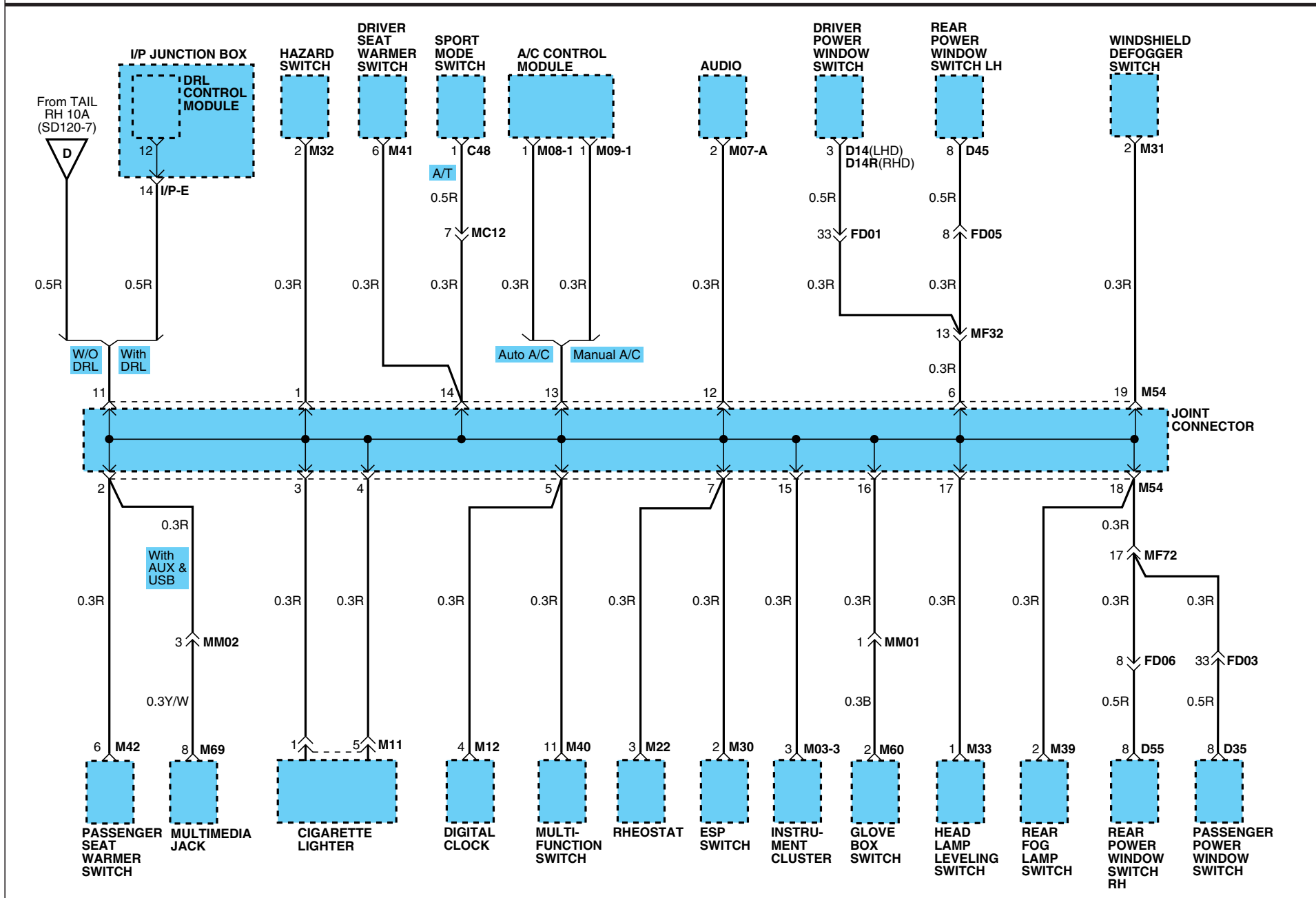

# PASSENGER COMPARTMENT FUSE DETAILS

## Passenger Compartment Fuse Details (9)

SD120-9

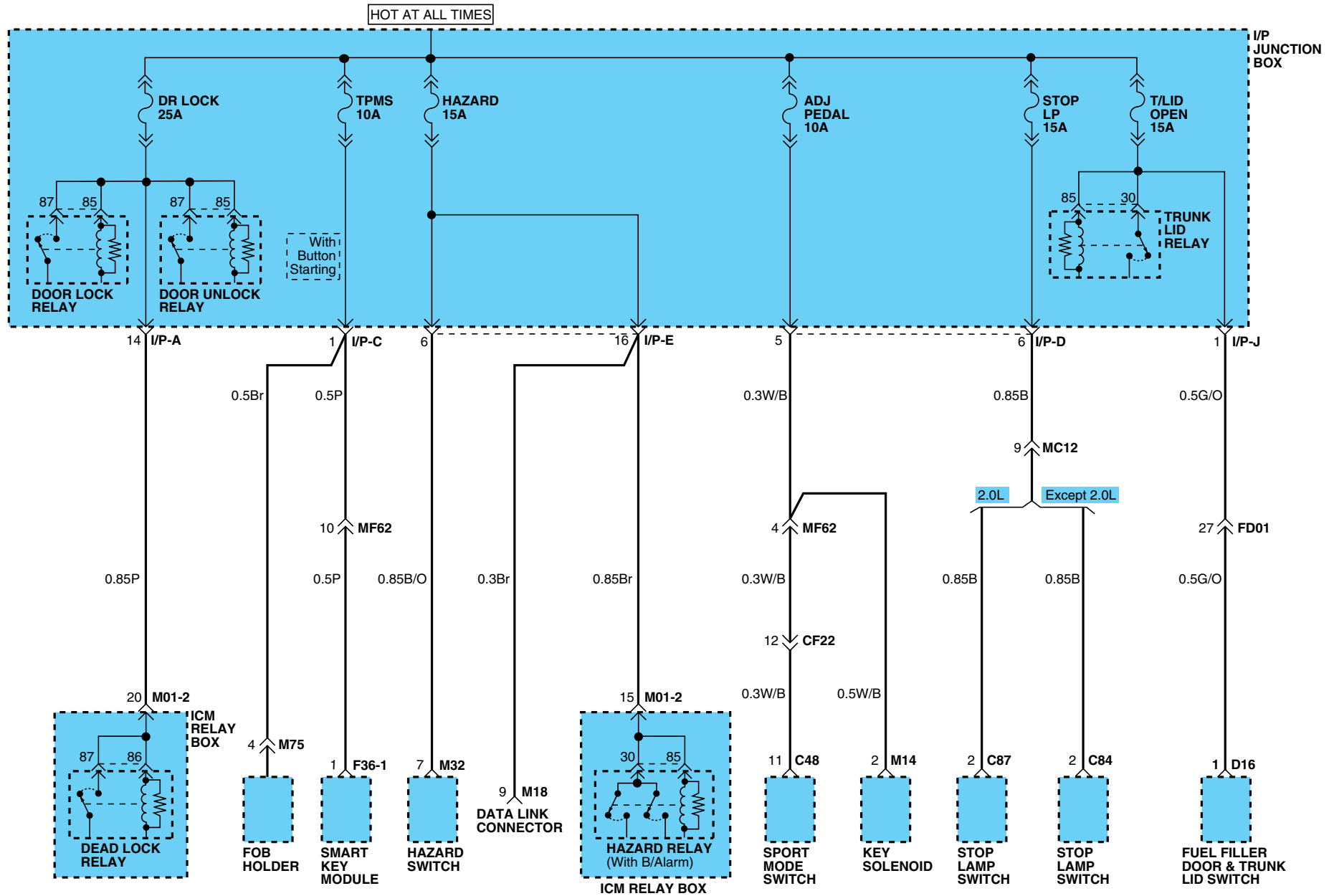



**PASSENGER COMPARTMENT FUSE DETAILS**

Passenger Compartment Fuse Details (10)

**SD120-10**

**MEMO**

# GROUND DISTRIBUTION

E4D345F3

## Ground Distribution (1)

SD130-1

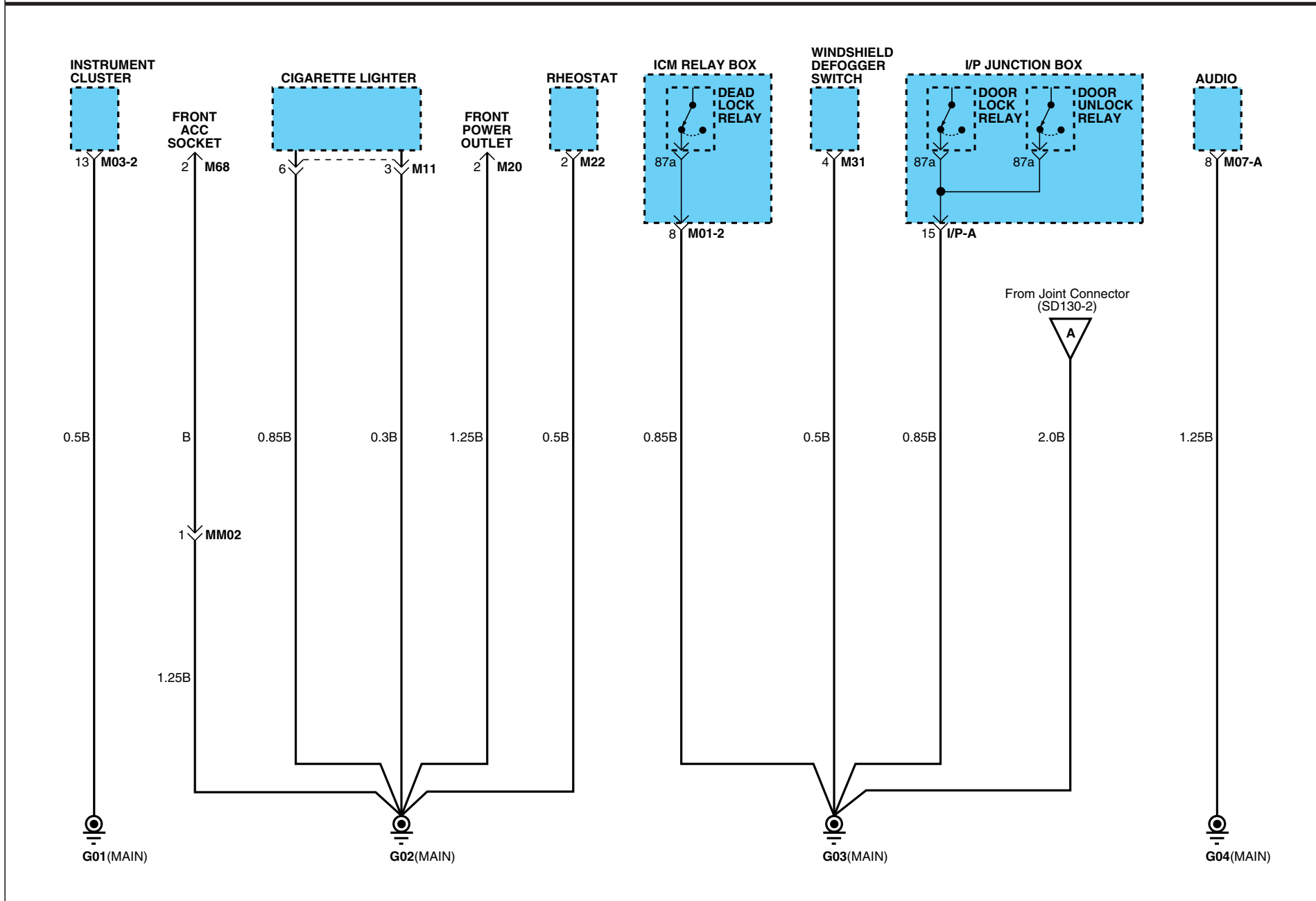

# GROUND DISTRIBUTION

## Ground Distribution (2)

SD130-2

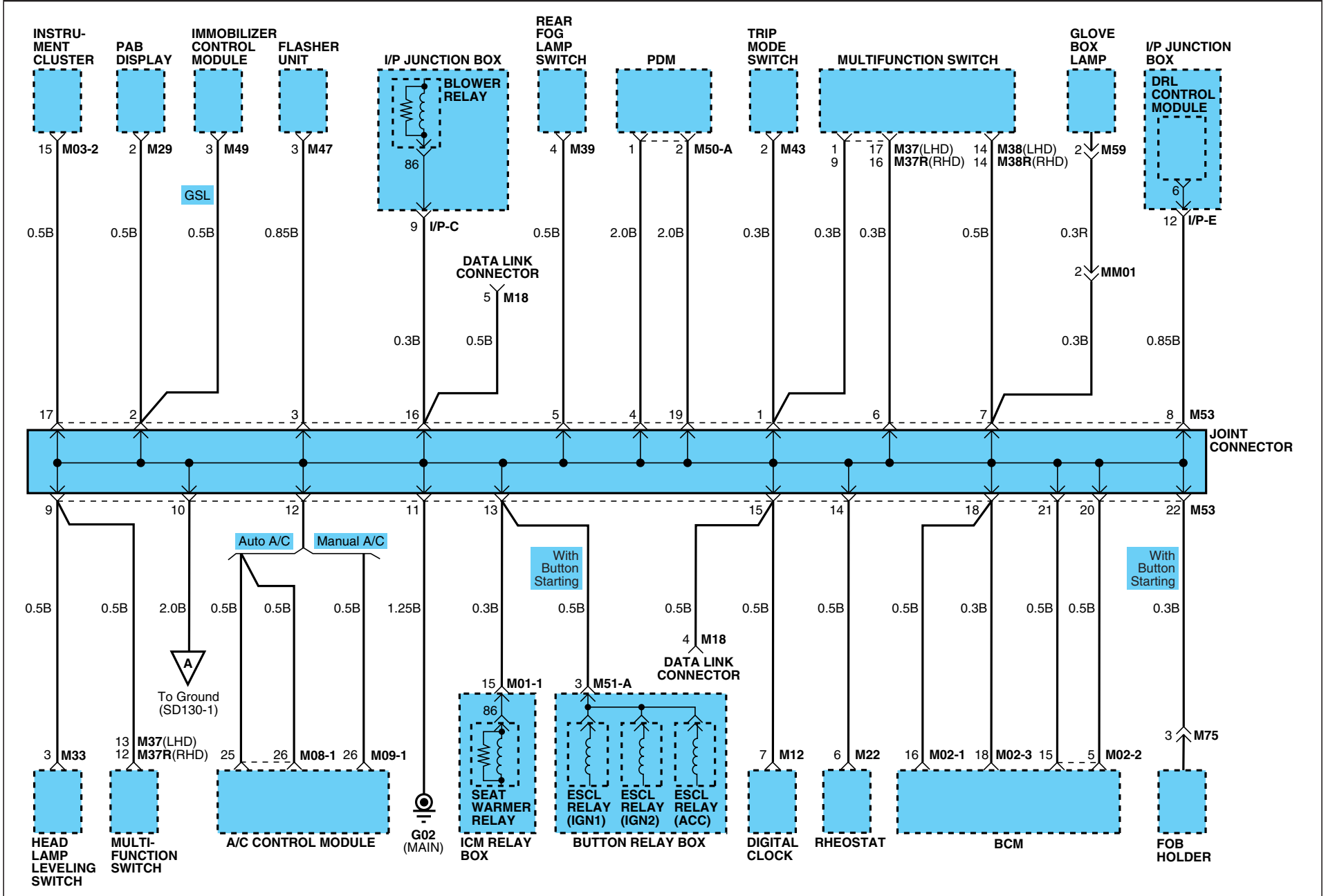

# GROUND DISTRIBUTION

## Ground Distribution (3)

SD130-3

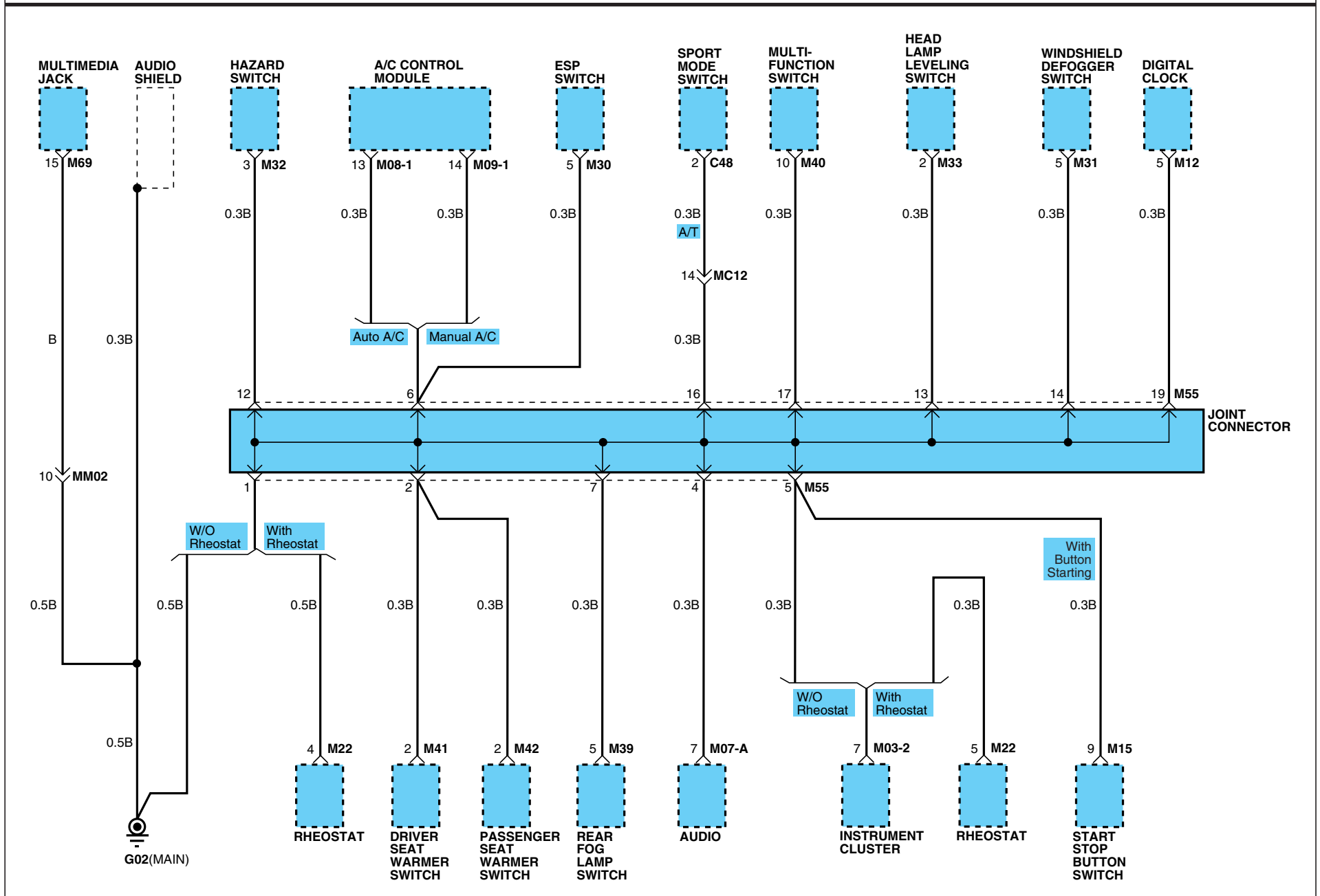

# GROUND DISTRIBUTION

## Ground Distribution (4)

SD130-4

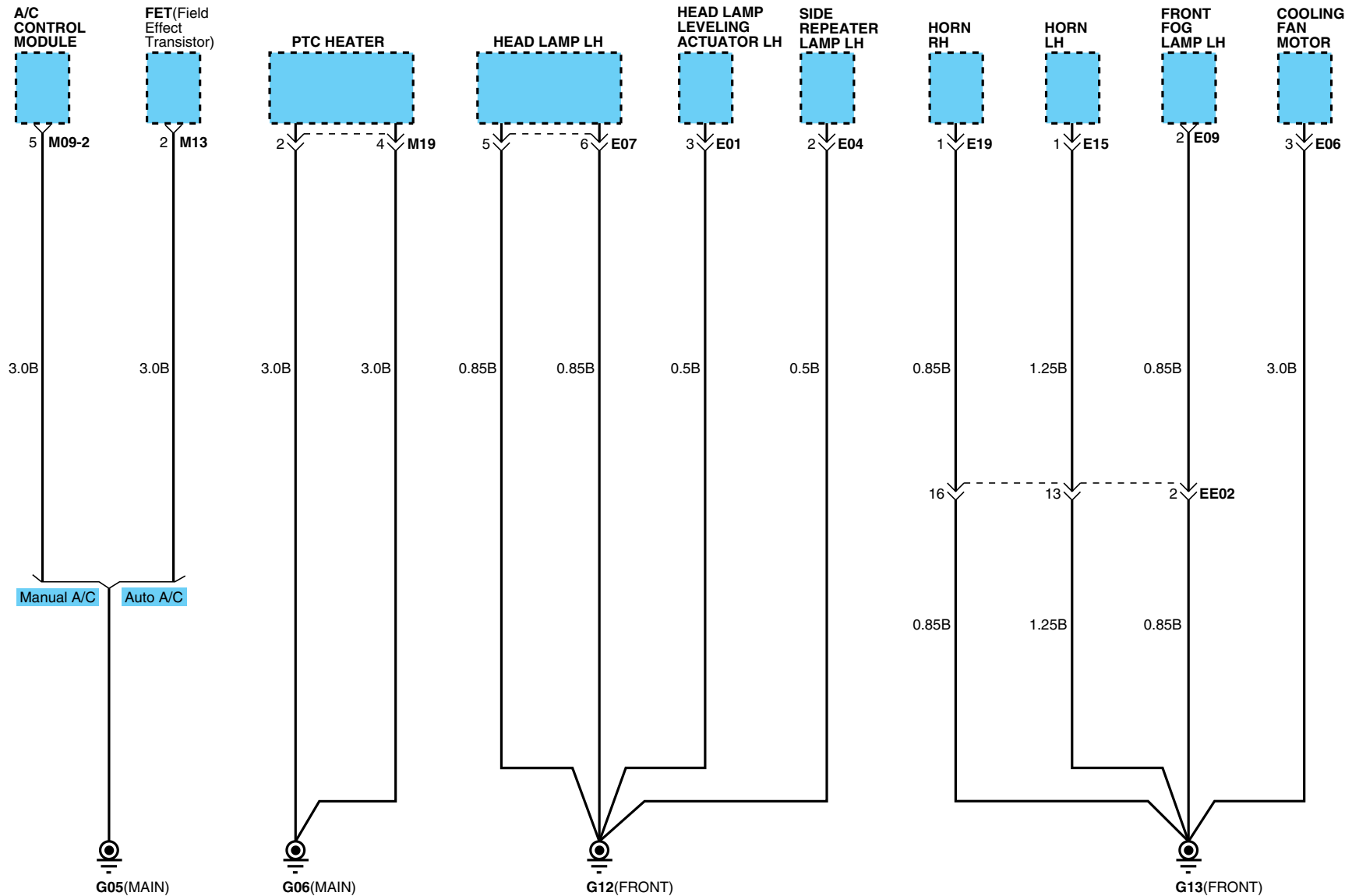

# GROUND DISTRIBUTION

## Ground Distribution (5)

SD130-5

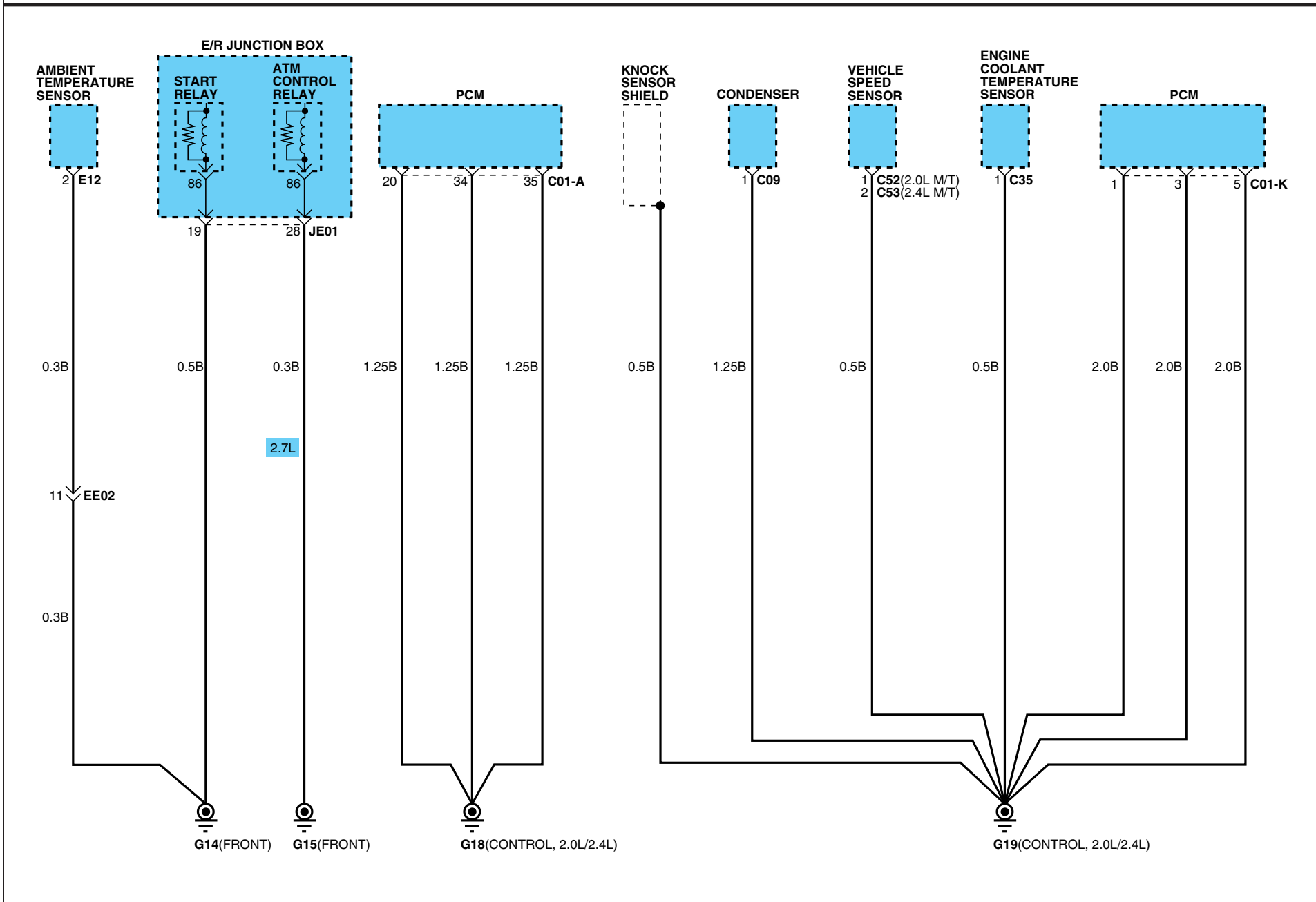

# GROUND DISTRIBUTION

## Ground Distribution (6)

SD130-6

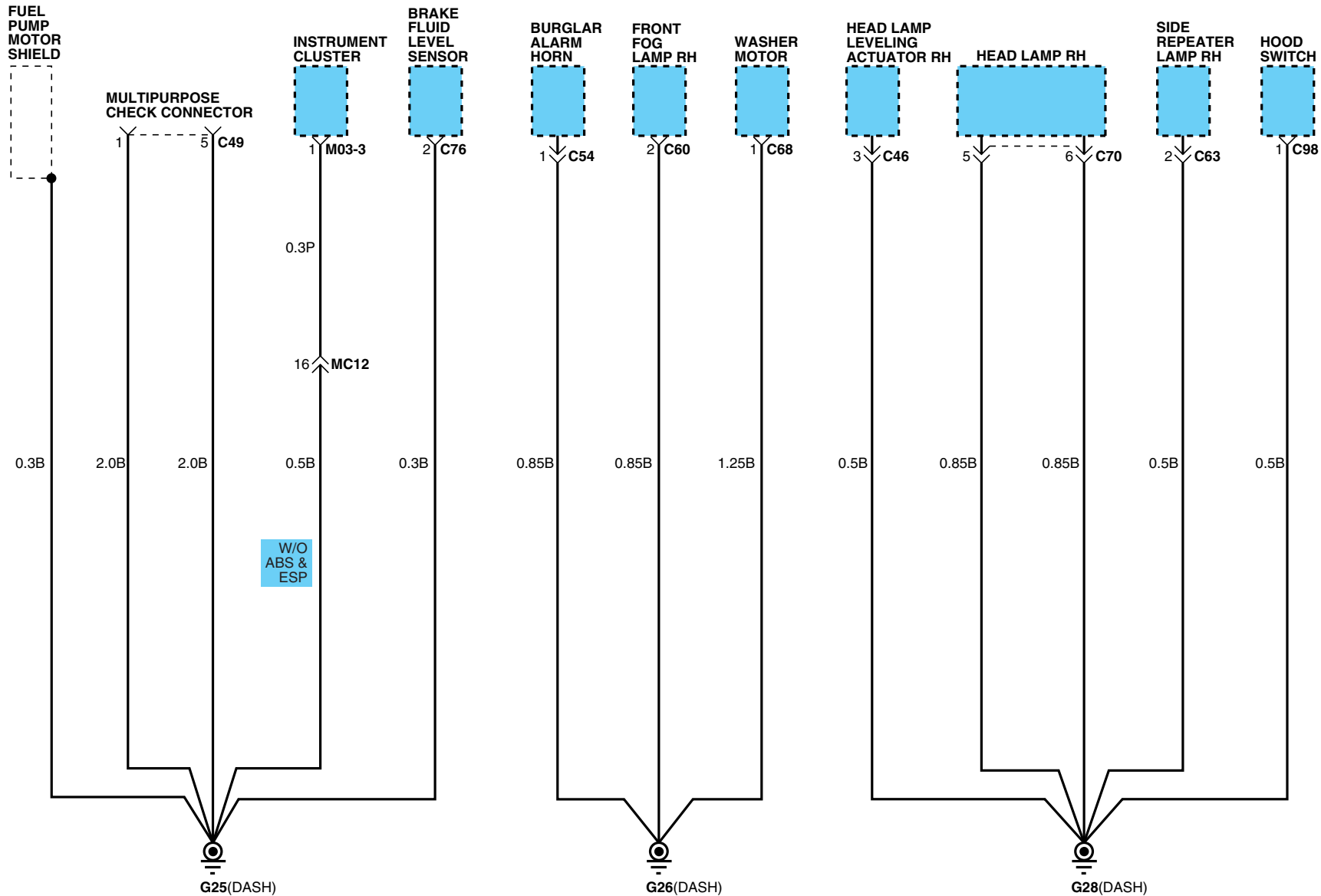

# GROUND DISTRIBUTION

## Ground Distribution (7)

SD130-7

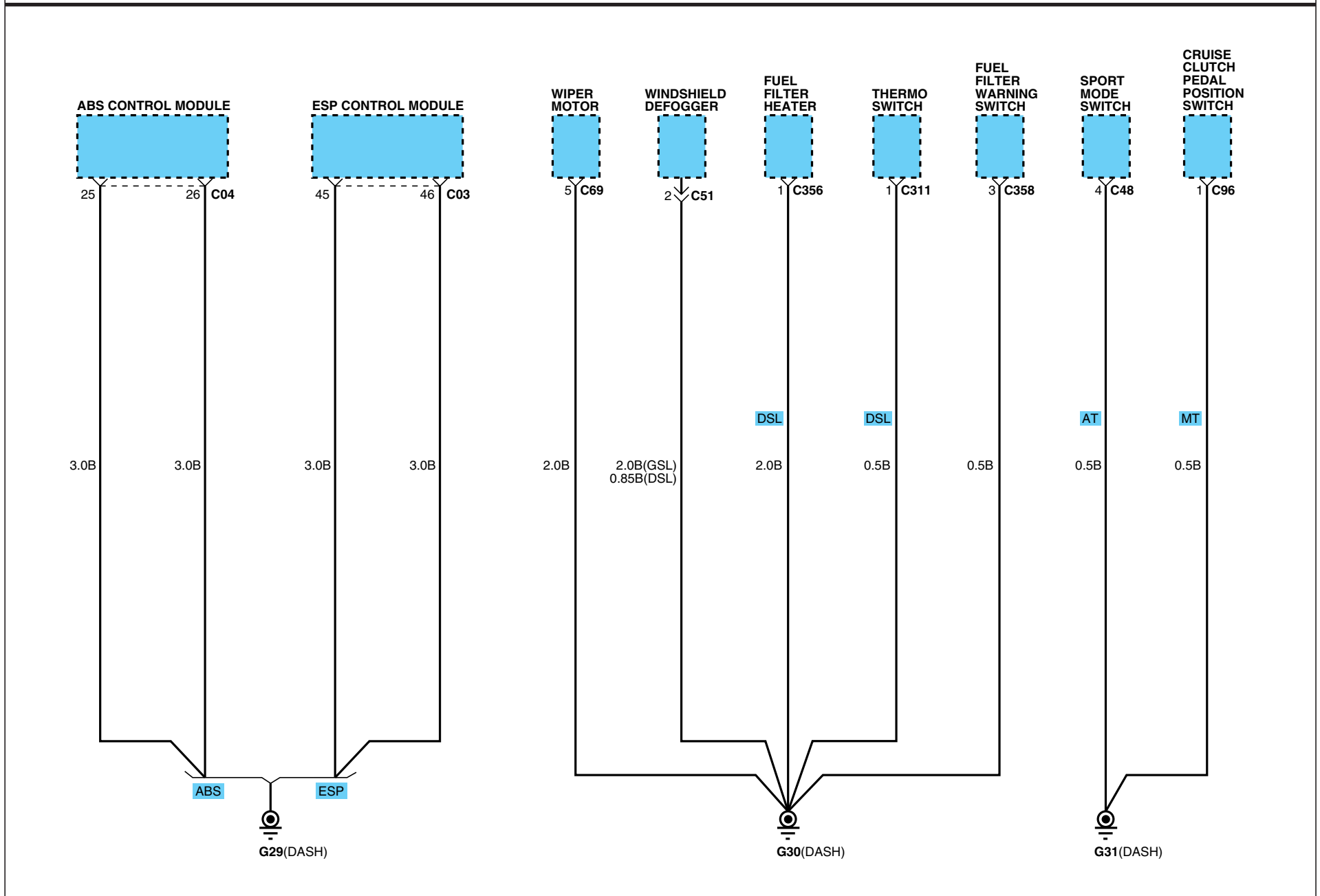



# GROUND DISTRIBUTION

## Ground Distribution (8)

SD130-8

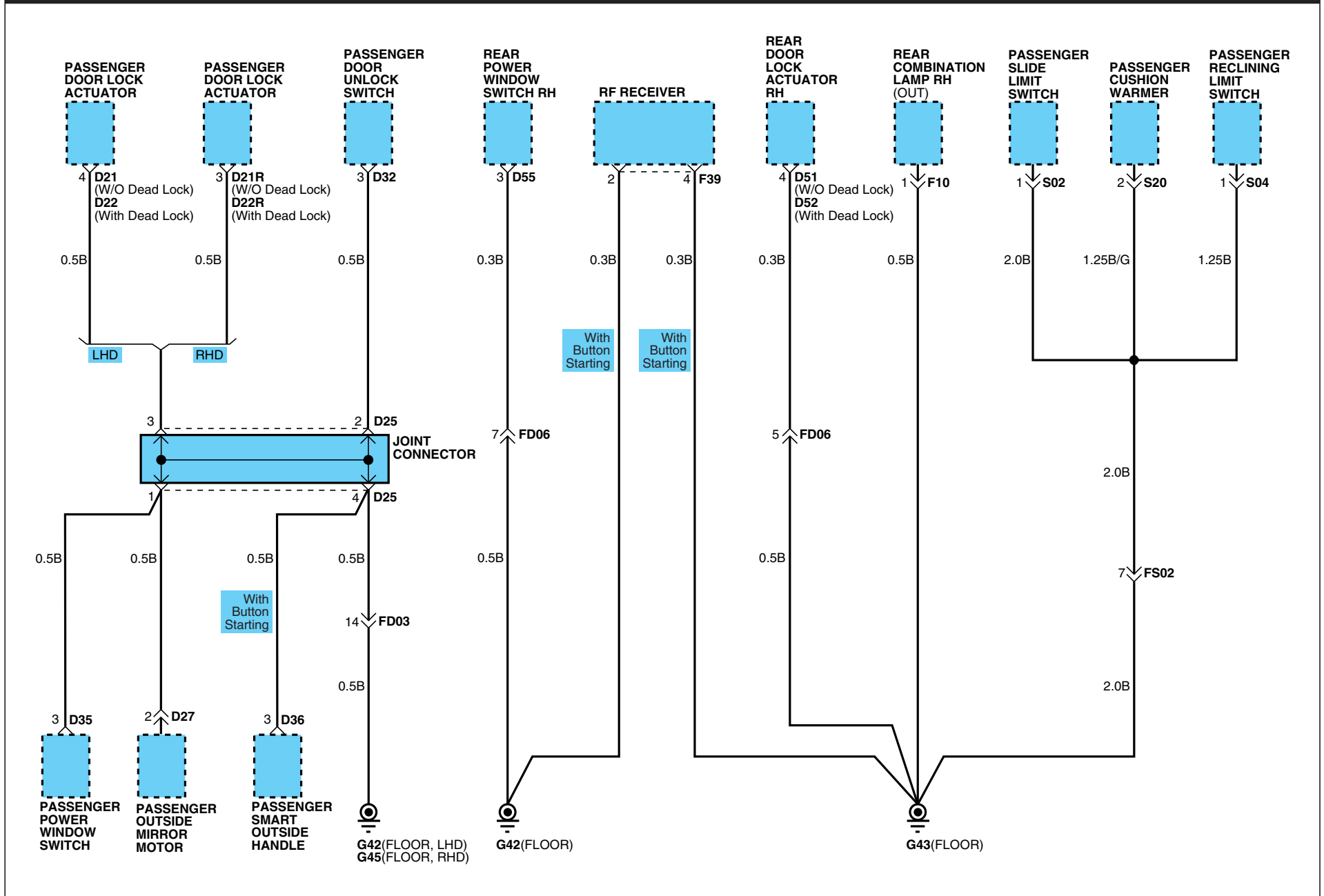

# GROUND DISTRIBUTION

## Ground Distribution (9)

SD130-9

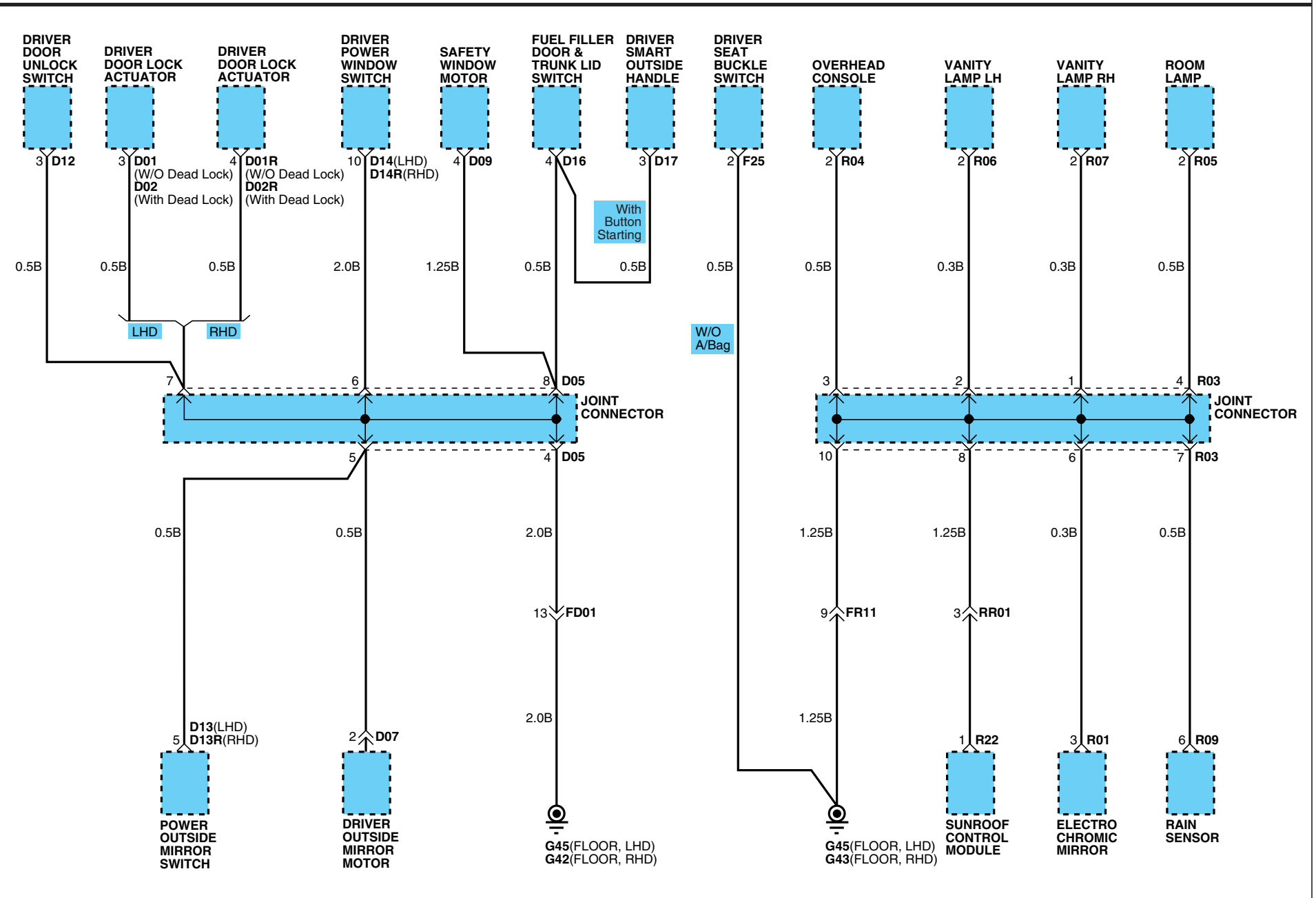

# GROUND DISTRIBUTION

## Ground Distribution (10)

SD130-10

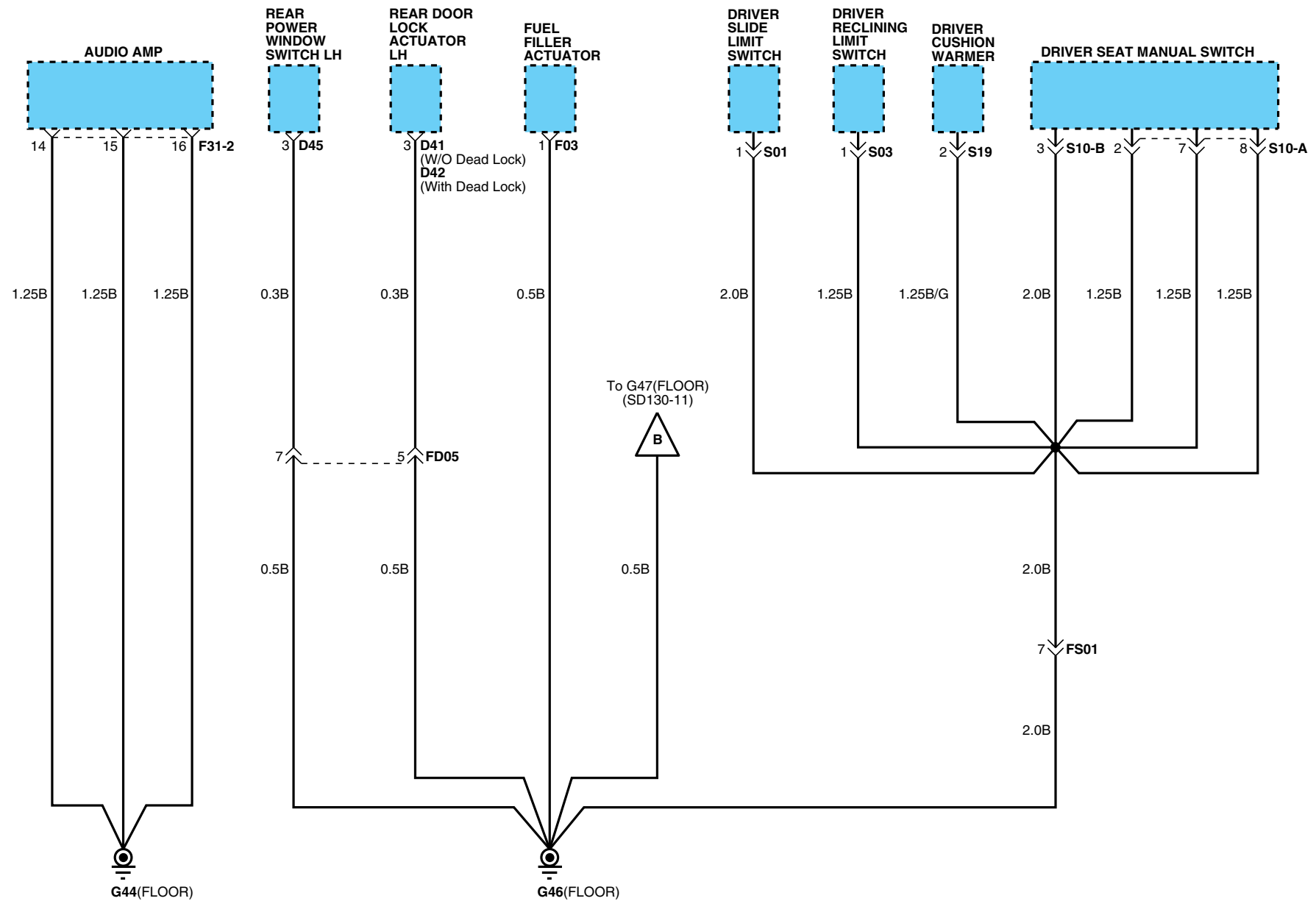

# GROUND DISTRIBUTION

## Ground Distribution (11)

SD130-11

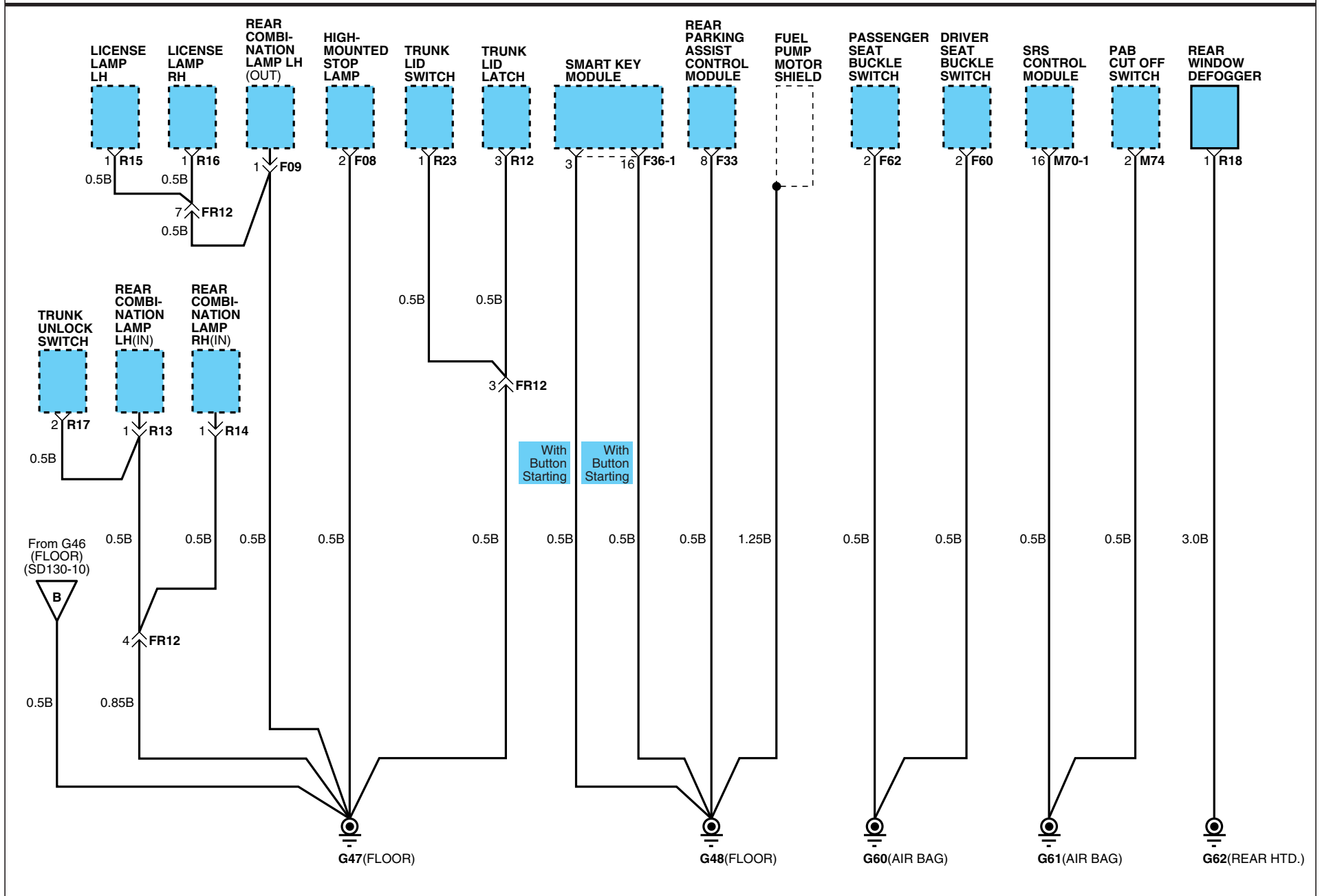

# GROUND DISTRIBUTION

## Ground Distribution (12)

SD130-12

### 2.7L

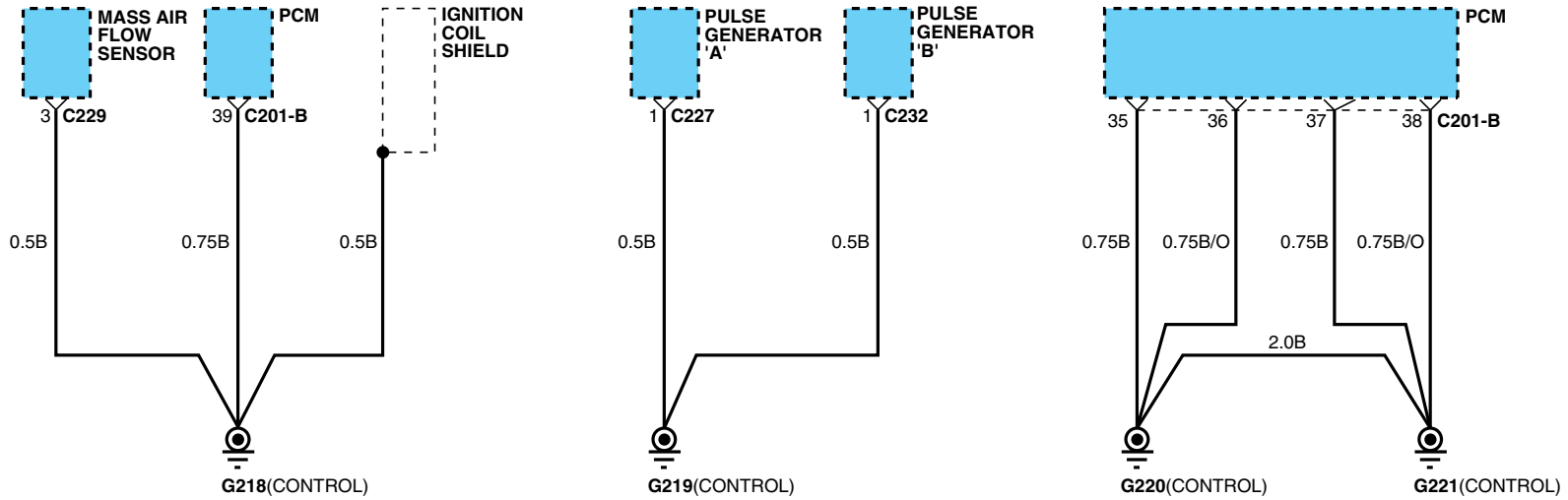

### DSL

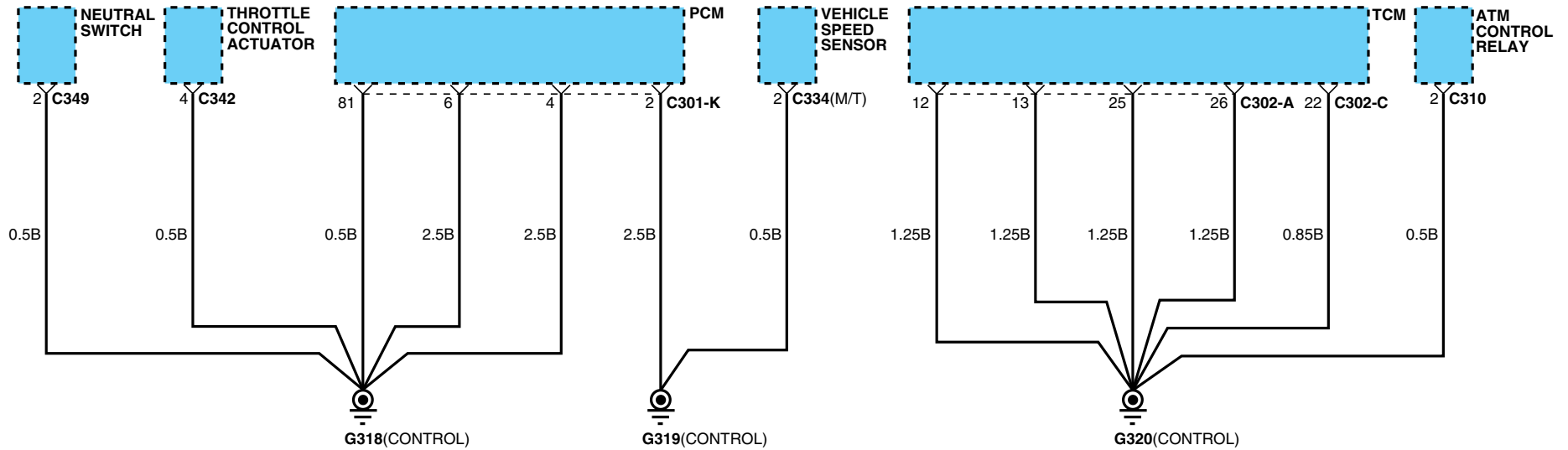

Data Link Details (1)

SD200-1

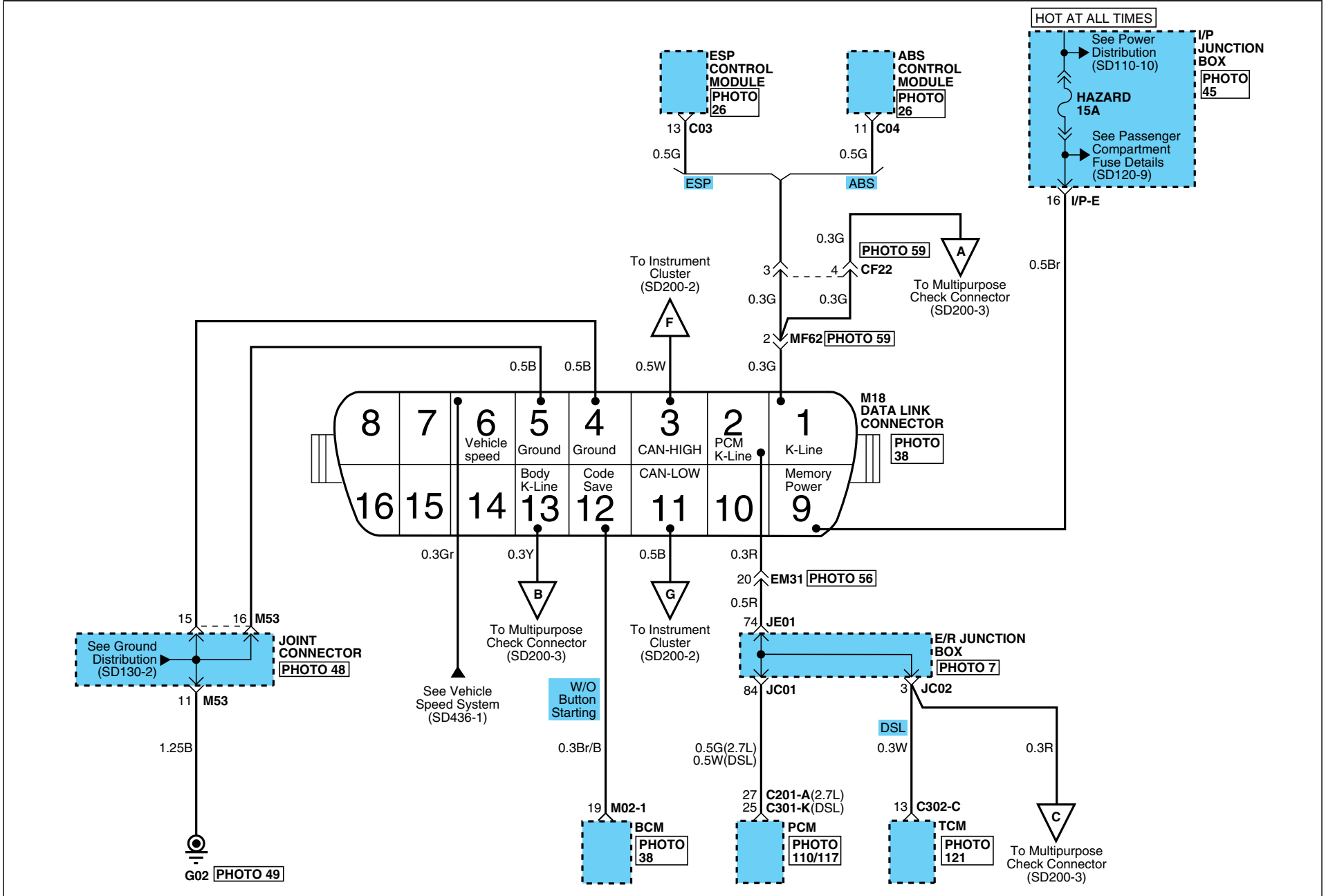

# DATA LINK DETAILS

## Data Link Details (2)

SD200-2

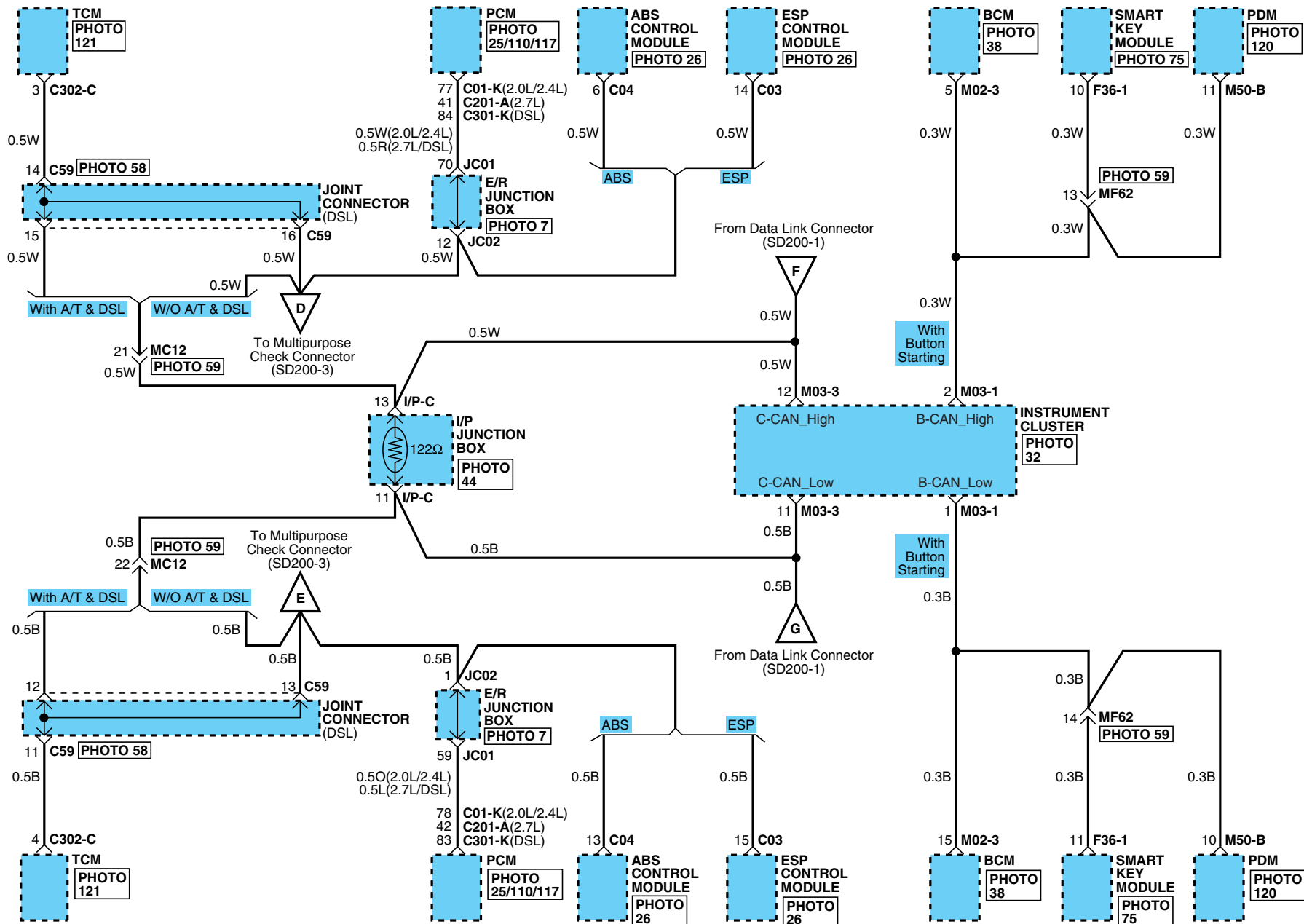

# DATA LINK DETAILS

## Data Link Details (3)

SD200-3

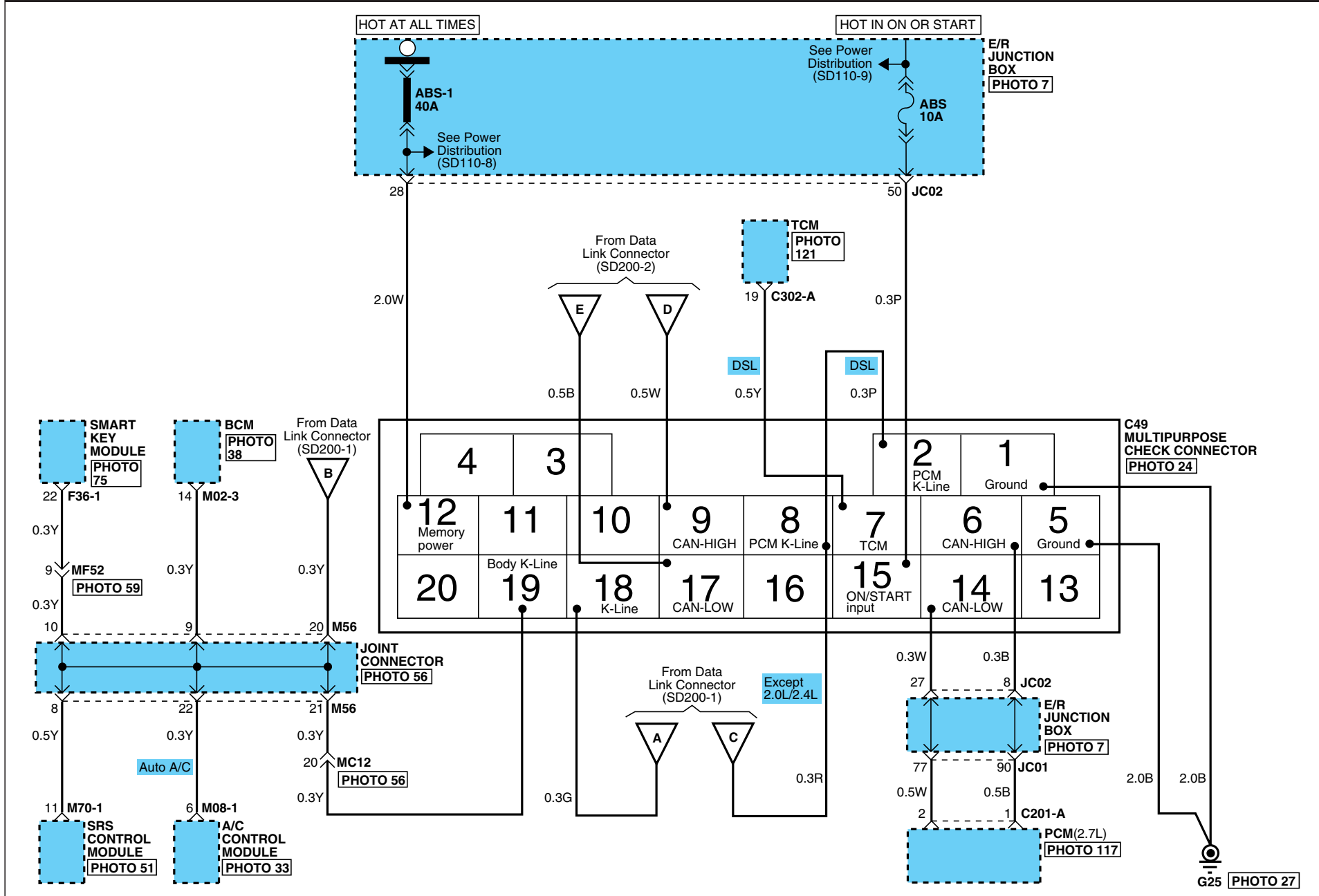



# DATA LINK DETAILS

## Data Link Details (4)

SD200-4

**C01-K**

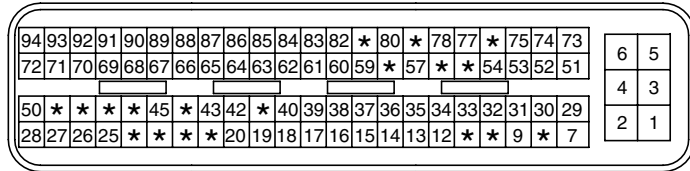

AMP\_PCU\_94F\_B\_SIE

**C03**

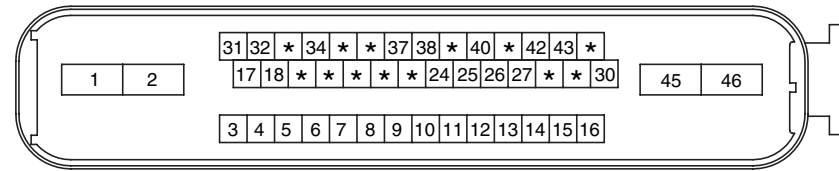

AMP\_ESP\_46F\_B

**C04**

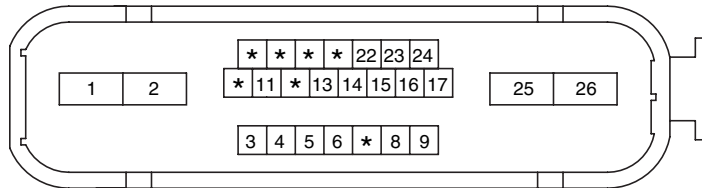

AMP\_ABS\_26F\_B

**C301-K**

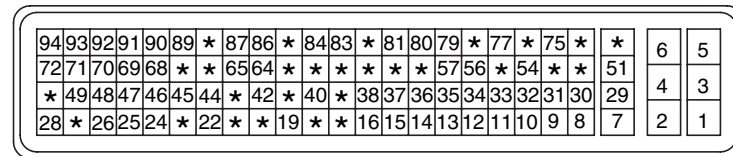

AMP\_PCU\_94F\_B\_SIE

**C49**

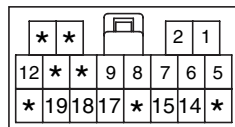

KET\_070\_20F\_B\_CHK

**C302-A**

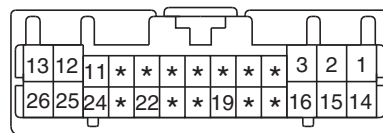

KET\_0407\_26F\_W

**C201-A**

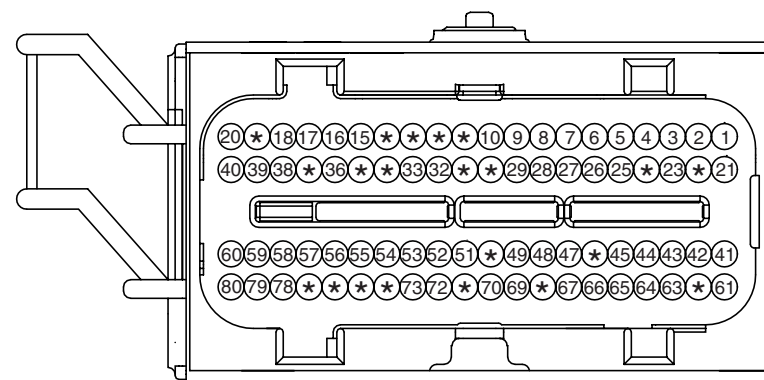

PKD\_ECU\_80F\_GR\_1

**C302-C**

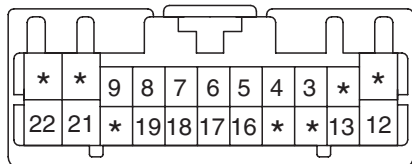

KET\_0407\_22F\_W

**F36-1**

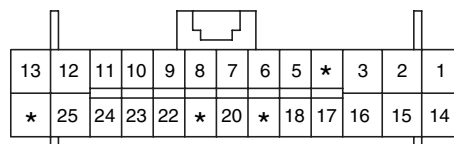

AMP\_0407\_26F\_W\_HD

**M02-1**

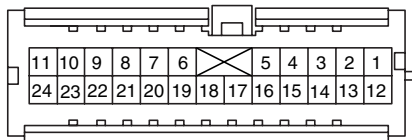

KET\_040III\_24F\_W

**M02-3**

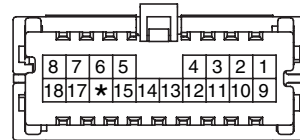

KET\_040III\_18F\_W

**M03-1**

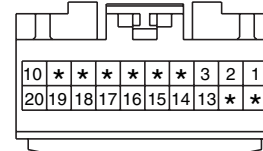

MLX\_040III\_20F\_Gr

**M03-3**

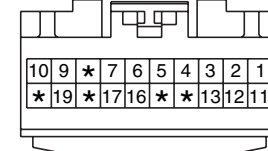

MLX\_040III\_20F\_Gr

# DATA LINK DETAILS

## Data Link Details (5)

SD200-5

**M08-1**

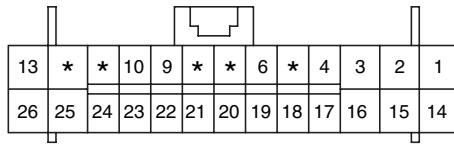

AMP\_0407\_26F\_W\_HD

**M18**

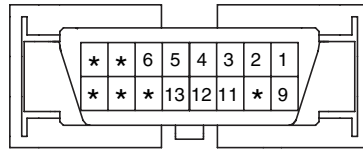

MLX\_OBDII\_16F\_B\_SIN

**M50-B**

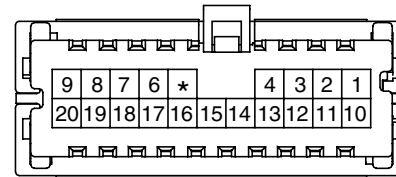

KET\_040III\_20F

**M70-1**



AMP\_ACU\_24F

**DATA LINK DETAILS**

Data Link Details (6)

**SD200-6**

**MEMO**

Cooling System (1)

SD253-1

2.0L/2.4L

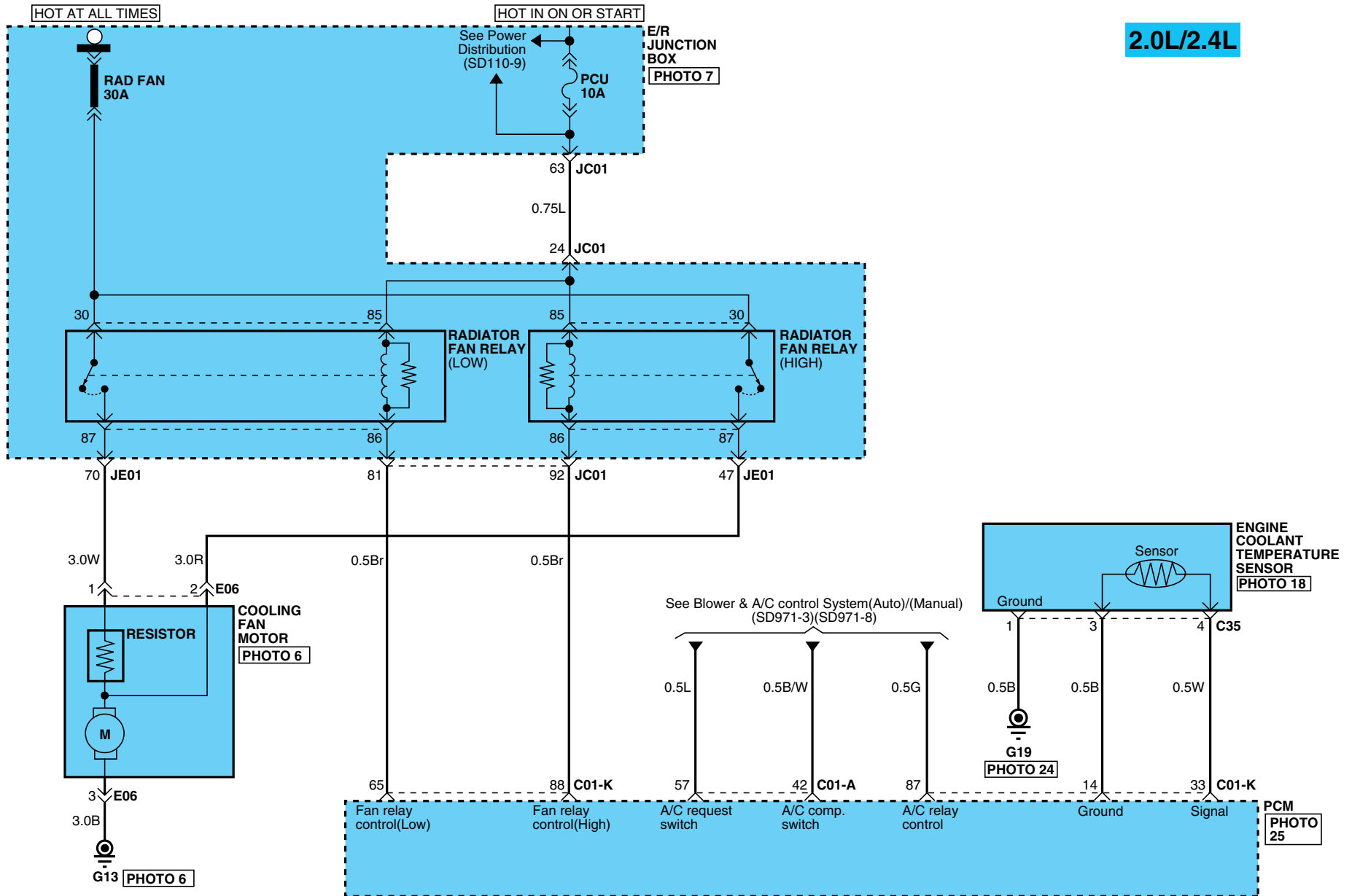

# COOLING SYSTEM

## Cooling System (2)

SD253-2

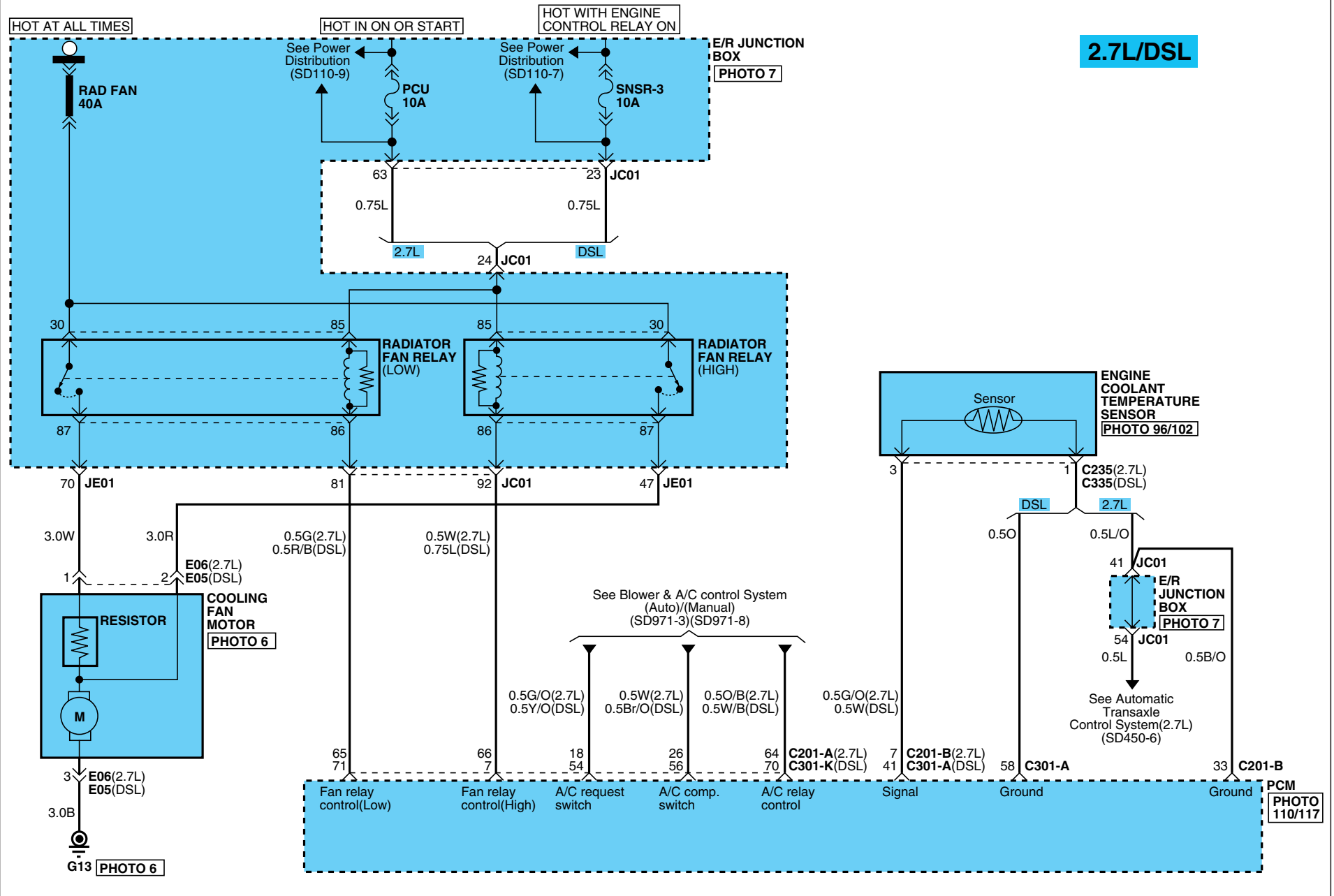

# COOLING SYSTEM

## Cooling System (3)

SD253-3

**C01-A**

*	*	58	57	*	55	54	53	52	51	50	49	48	47	46
*	44	43	42	*	40	39	38	*	36	35	34	33	32	31
30	29	*	*	26	25	24	*	*	*	20	19	18	17	16
15	14	*	12	11	10	9	*	*	*	5	4	3	2	1

AMP\_TCU\_60F\_B\_SIE

**C01-K**

94	93	92	91	90	89	88	87	86	85	84	83	82	*	80	*	78	77	*	75	74	73	6	5
72	71	70	69	68	67	66	65	64	63	62	61	60	59	*	57	*	*	54	53	52	51	4	3
50	*	*	*	*	45	*	43	42	*	40	39	38	37	36	35	34	33	32	31	30	29	2	1
28	27	26	25	*	*	*	*	20	19	18	17	16	15	14	13	12	*	*	9	*	7		

AMP\_PCU\_94F\_B\_SIE

**C201-A**

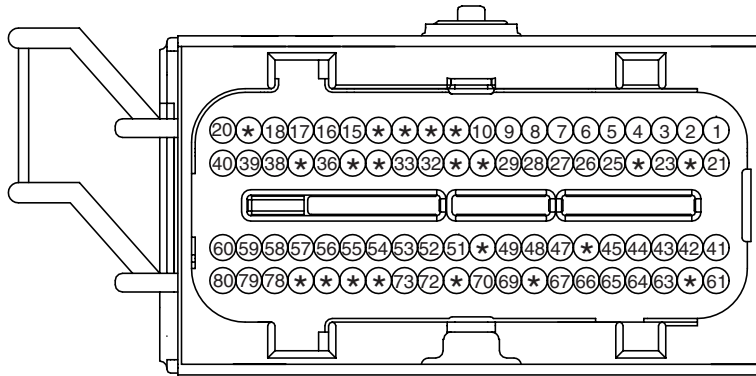

PKD\_ECU\_80F\_GR\_1

**C201-B**

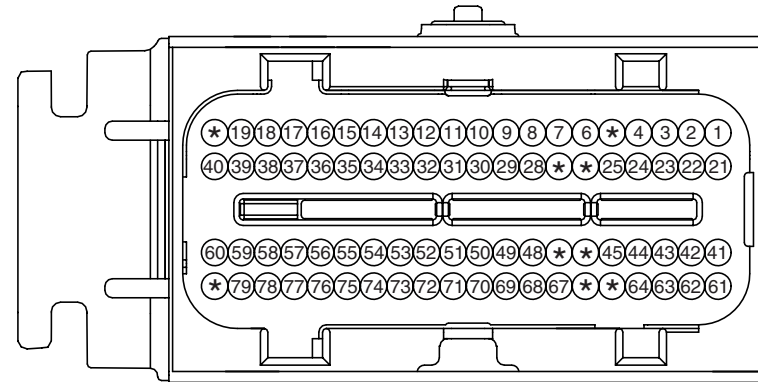

PKD\_ECU\_80F\_B\_2

**C35**



AMP\_EJWP\_04F\_B

**C235/C335**

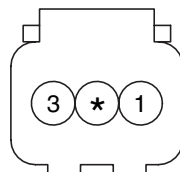

KUM\_WTS\_03F\_B

**C301-A**

60	59	58	*	56	*	*	53	*	*	50	49	*	47	46
45	44	43	42	41	40	*	*	37	*	*	34	33	*	31
30	*	28	27	26	*	*	23	*	*	20	19	*	17	16
*	*	13	12	*	*	*	8	7	6	*	4	*	2	1

AMP\_TCU\_60F\_B\_SIE

**C301-K**

94	93	92	91	90	89	*	87	86	*	84	83	*	81	80	79	*	77	*	75	*	*	6	5
72	71	70	69	68	*	*	65	64	*	*	*	*	*	57	56	*	54	*	*	51		4	3
*	49	48	47	46	45	44	*	42	*	40	*	38	37	36	35	34	33	32	31	30	29	2	1
28	*	26	25	24	*	22	*	*	19	*	*	16	15	14	13	12	11	10	9	8	7		

AMP\_PCU\_94F\_B\_SIE

**E05**

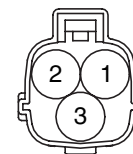

KET\_312IWP\_03\_F

**E06**

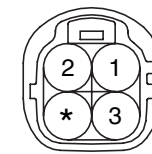

KET\_187IWP\_04F\_B

**COOLING SYSTEM**

**Cooling System (4)**

**SD253-4**

**MEMO**

MFI Control System (G4KD/G4KE-GSL 2.0L/2.4L) (1)

SD313-1

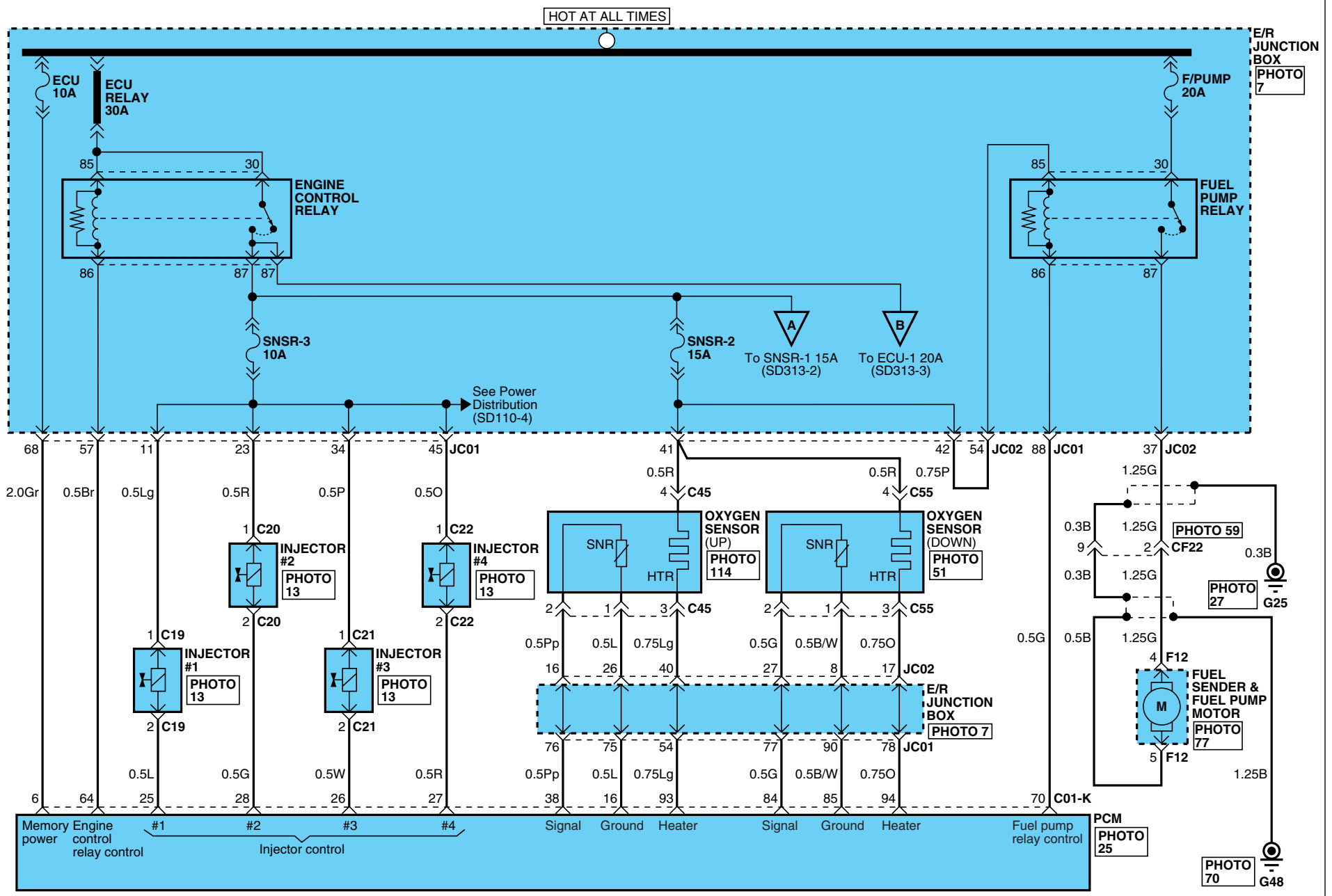



# MFI CONTROL SYSTEM

## MFI Control System (G4KD/G4KE-GSL 2.0L/2.4L) (2)

SD313-2

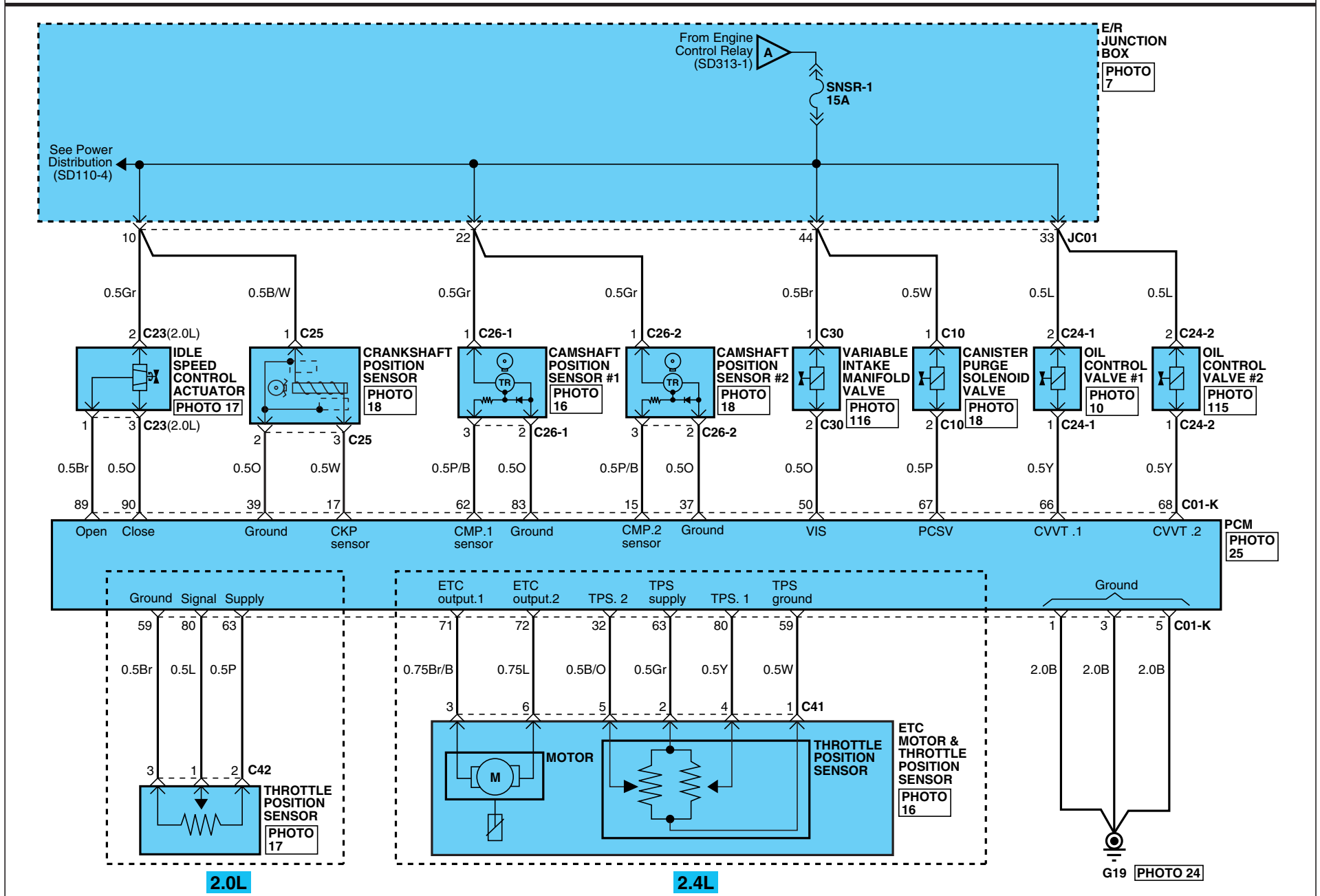

# MFI CONTROL SYSTEM

## MFI Control System (G4KD/G4KE-GSL 2.0L/2.4L) (3)

SD313-3

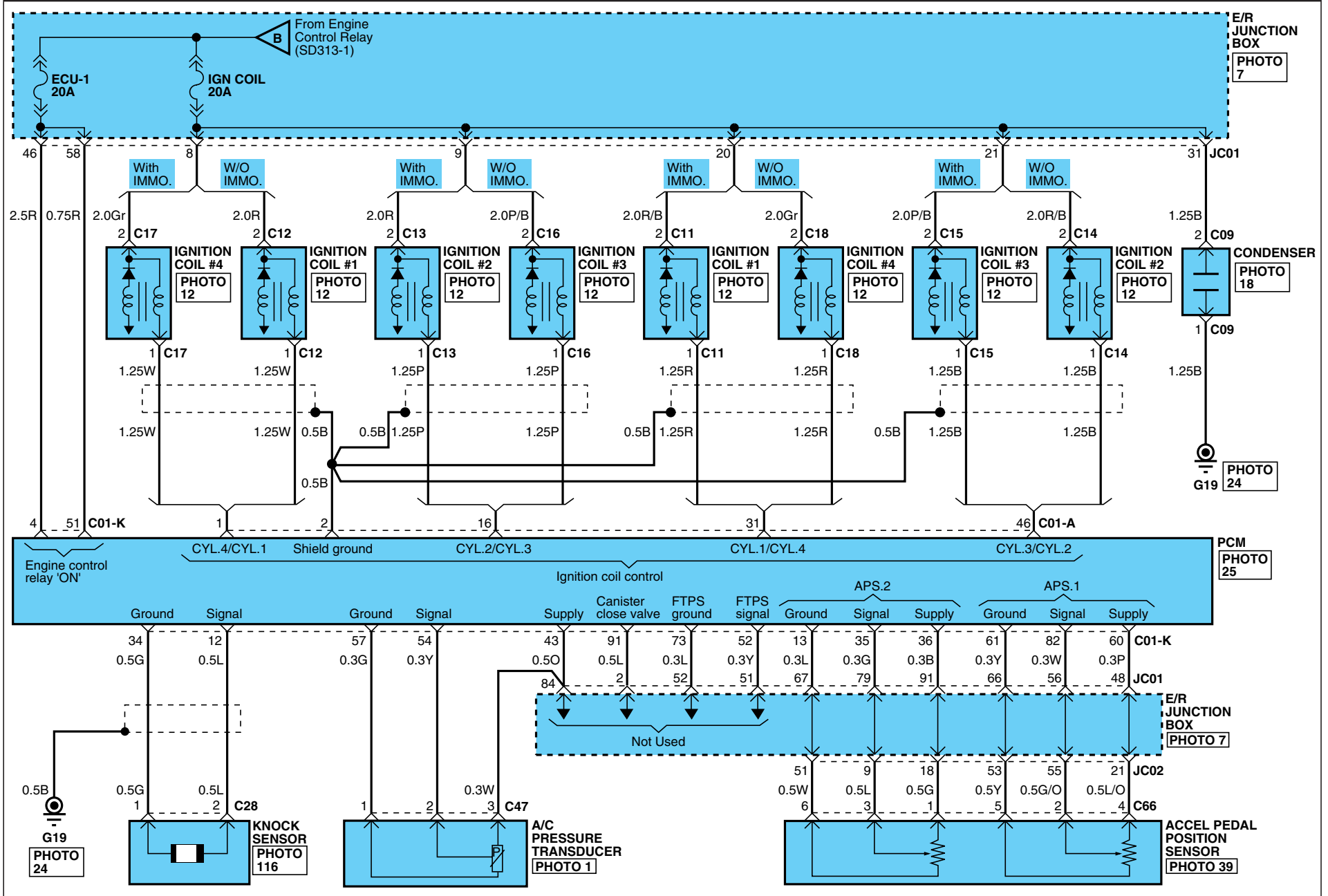

# MFI CONTROL SYSTEM

## MFI Control System (G4KD/G4KE-GSL 2.0L/2.4L) (4)

SD313-4

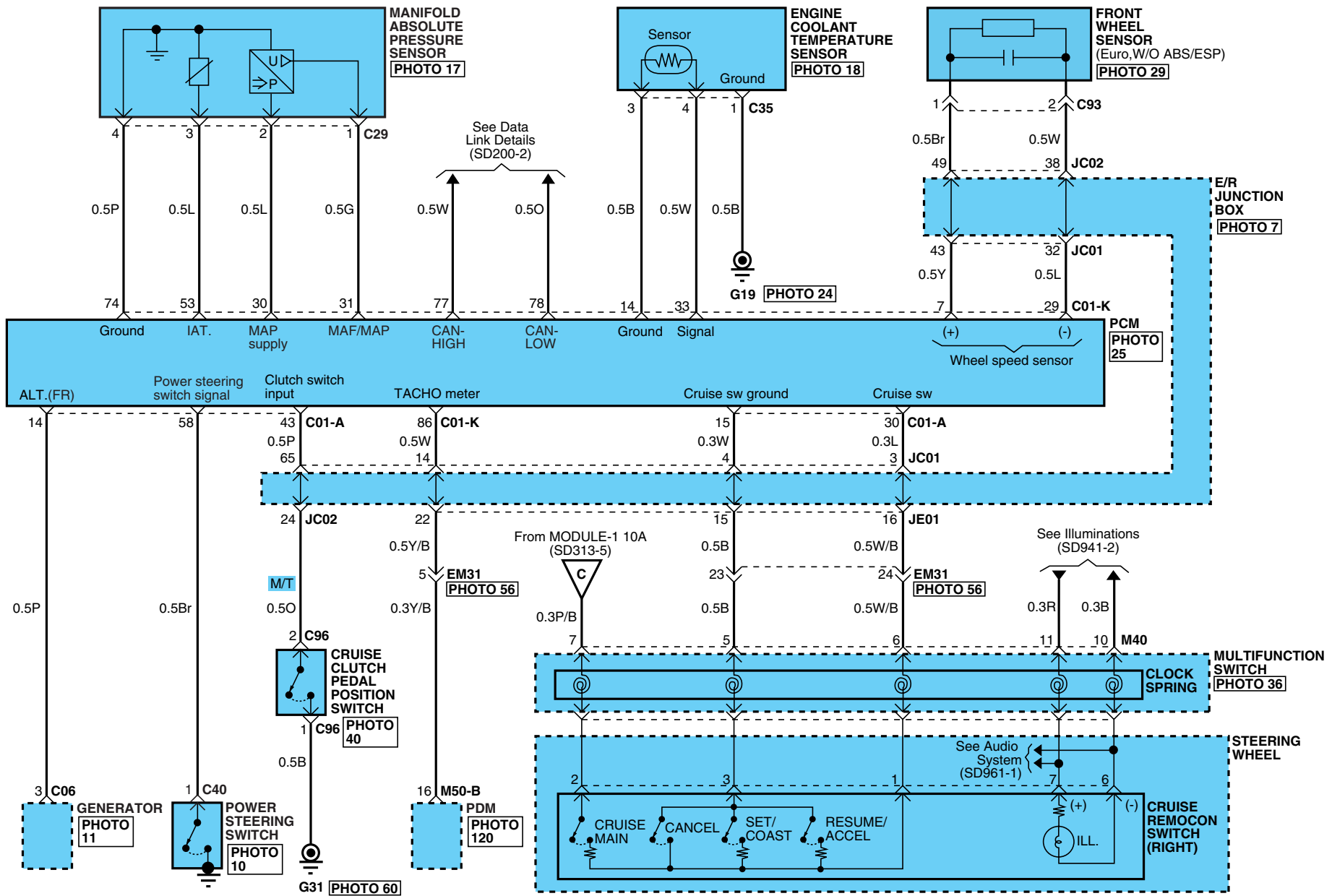

# MFI CONTROL SYSTEM

## MFI Control System (G4KD/G4KE-GSL 2.0L/2.4L) (5)

SD313-5

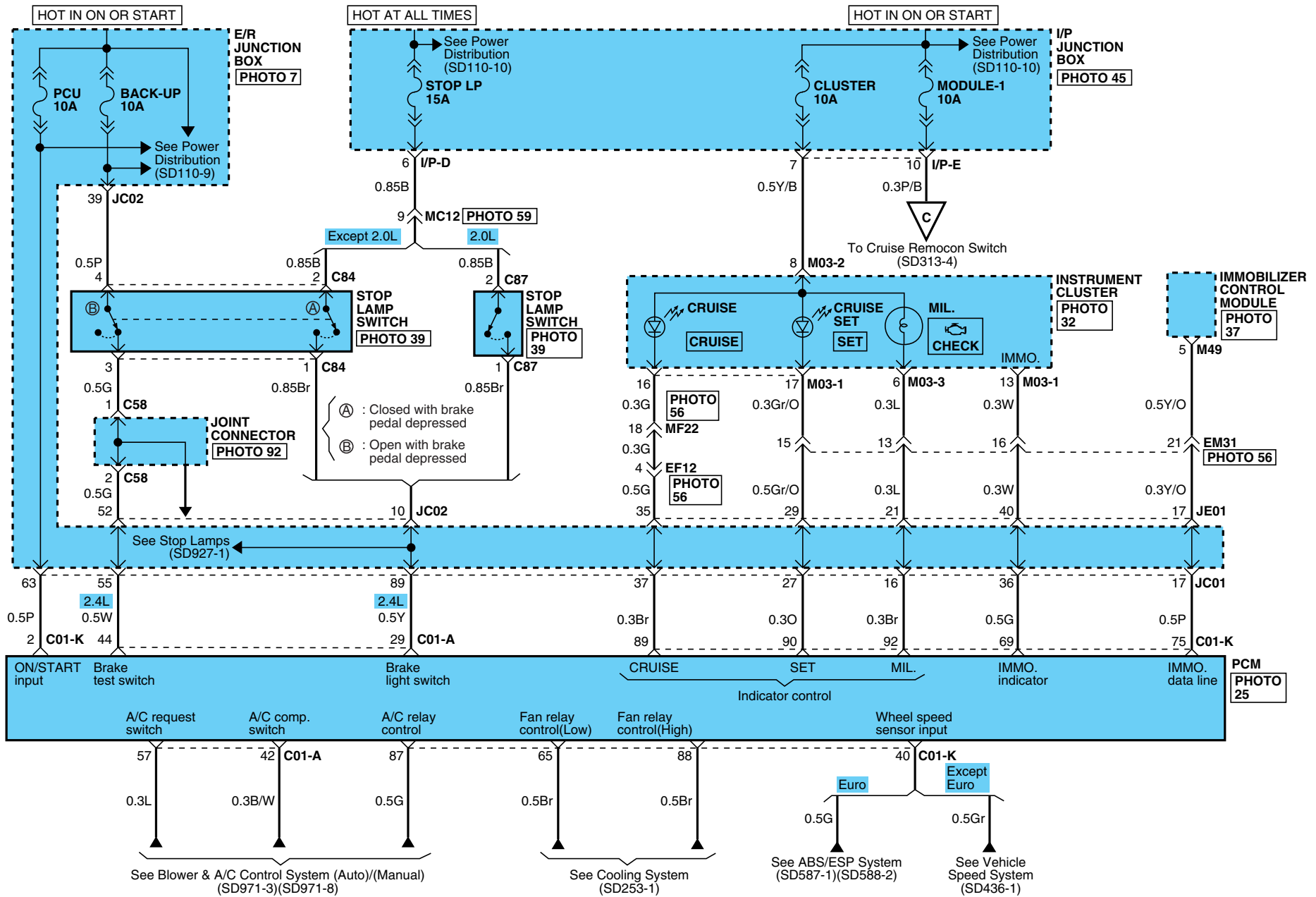

# MFI CONTROL SYSTEM

## MFI Control System (G4KD/G4KE-GSL 2.0L/2.4L) (6)

SD313-6

**C01-A**

*	*	58	57	*	55	54	53	52	51	50	49	48	47	46
*	44	43	42	*	40	39	38	*	36	35	34	33	32	31
30	29	*	*	26	25	24	*	*	*	20	19	18	17	16
15	14	*	12	11	10	9	*	*	*	5	4	3	2	1

AMP\_TCU\_60F\_B\_SIE

**C01-K**

94	93	92	91	90	89	88	87	86	85	84	83	82	*	80	*	78	77	*	75	74	73	6	5
72	71	70	69	68	67	66	65	64	63	62	61	60	59	*	57	*	*	54	53	52	51	4	3
50	*	*	*	*	45	*	43	42	*	40	39	38	37	36	35	34	33	32	31	30	29	2	1
28	27	26	25	*	*	*	*	20	19	18	17	16	15	14	13	12	*	*	9	*	7		

AMP\_PCU\_94F\_B\_SIE

**C06**

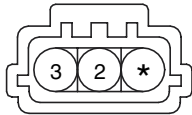

KET\_090IWP\_03F\_B

**C09**



MLX\_090CIGAR\_02F\_B

**C10**

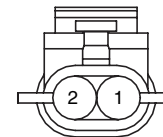

PKD\_MP150\_02F\_B

**C11/C13/C15/C17**

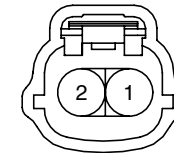

KET\_090IWP\_02F\_B

**C12/C14/C16/C18**

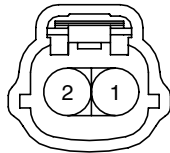

KET\_090IWP\_02F\_B

**C19/C20/C21/C22**

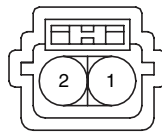

KUM\_NDWP\_02F\_GR

**C23**

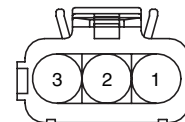

AMP\_JPT\_03F\_B\_BOSCH

**C24-1/C24-2**



KET\_090WP\_02F\_B\_L

**C25**

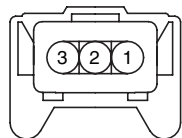

AMP\_JPT\_03F\_B\_S2

**C26-1/C26-2**

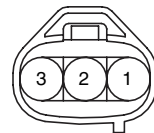

SUM\_090IWP\_03F\_GR\_R

**C28**

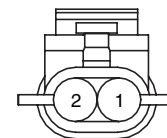

PKD\_MP150\_02F\_GR

**C29**

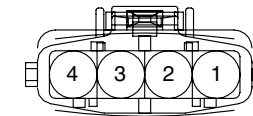

AMP\_JPT\_04F\_B\_BOSCH

**C30**

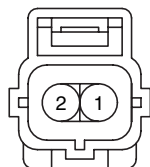

AMP\_EJWP\_02F\_B

**C35**



AMP\_EJWP\_04F\_B

**C40**

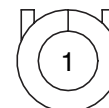

MOLEX\_35012\_0101

**C41**

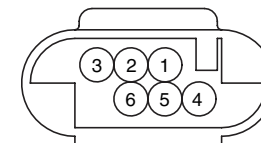

AMP\_MQSWP\_06F\_B\_1

# MFI CONTROL SYSTEM

## MFI Control System (G4KD/G4KE-GSL 2.0L/2.4L) (7)

SD313-7

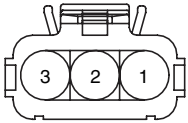
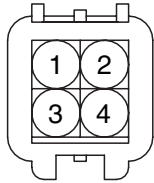
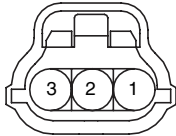
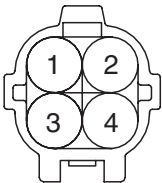
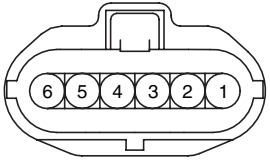
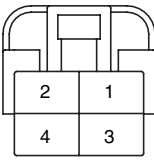
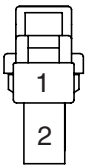
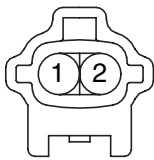
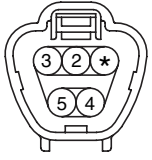
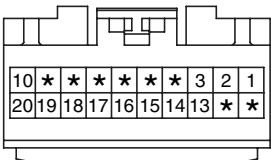
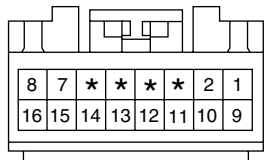
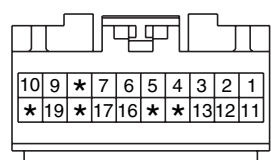
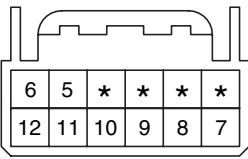
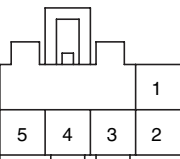
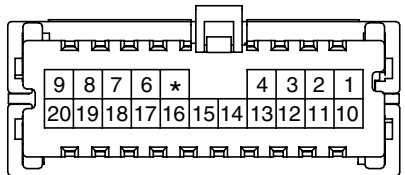
<p><b>C42</b></p>  <p>AMP_JPT_03F_B_BOSCH</p>	<p><b>C45</b></p>  <p>KUM_NMWP_04M_B</p>	<p><b>C47</b></p>  <p>KET_040WP_03F_B</p>	<p><b>C55</b></p>  <p>KET_SWP_04M_B</p>
<p><b>C66</b></p>  <p>AMP_070WP_06F_B</p>	<p><b>C84</b></p>  <p>KET_250DL_04F_W</p>	<p><b>C87/C96</b></p>  <p>KET_250DL_02F_W</p>	<p><b>C93</b></p>  <p>KET_090IWP_02M_B</p>
<p><b>F12</b></p>  <p>KET_090IWP_05F_Gr_2</p>	<p><b>M03-1</b></p>  <p>MLX_040III_20F_Gr</p>	<p><b>M03-2</b></p>  <p>MLX_040III_16F_Gr</p>	<p><b>M03-3</b></p>  <p>MLX_040III_20F_Gr</p>
<p><b>M40</b></p>  <p>AMP_025_12F_W</p>	<p><b>M49</b></p>  <p>KUM_CDR_05F_W</p>	<p><b>M50-B</b></p>  <p>KET_040III_20F</p>	<p><b>BLANK</b></p>

## MFI CONTROL SYSTEM

MFI Control System (G4KD/G4KE-GSL 2.0L/2.4L) (8)

SD313-8

MEMO

MFI Control System (G6EA-GSL 2.7L) (1)

SD313-9

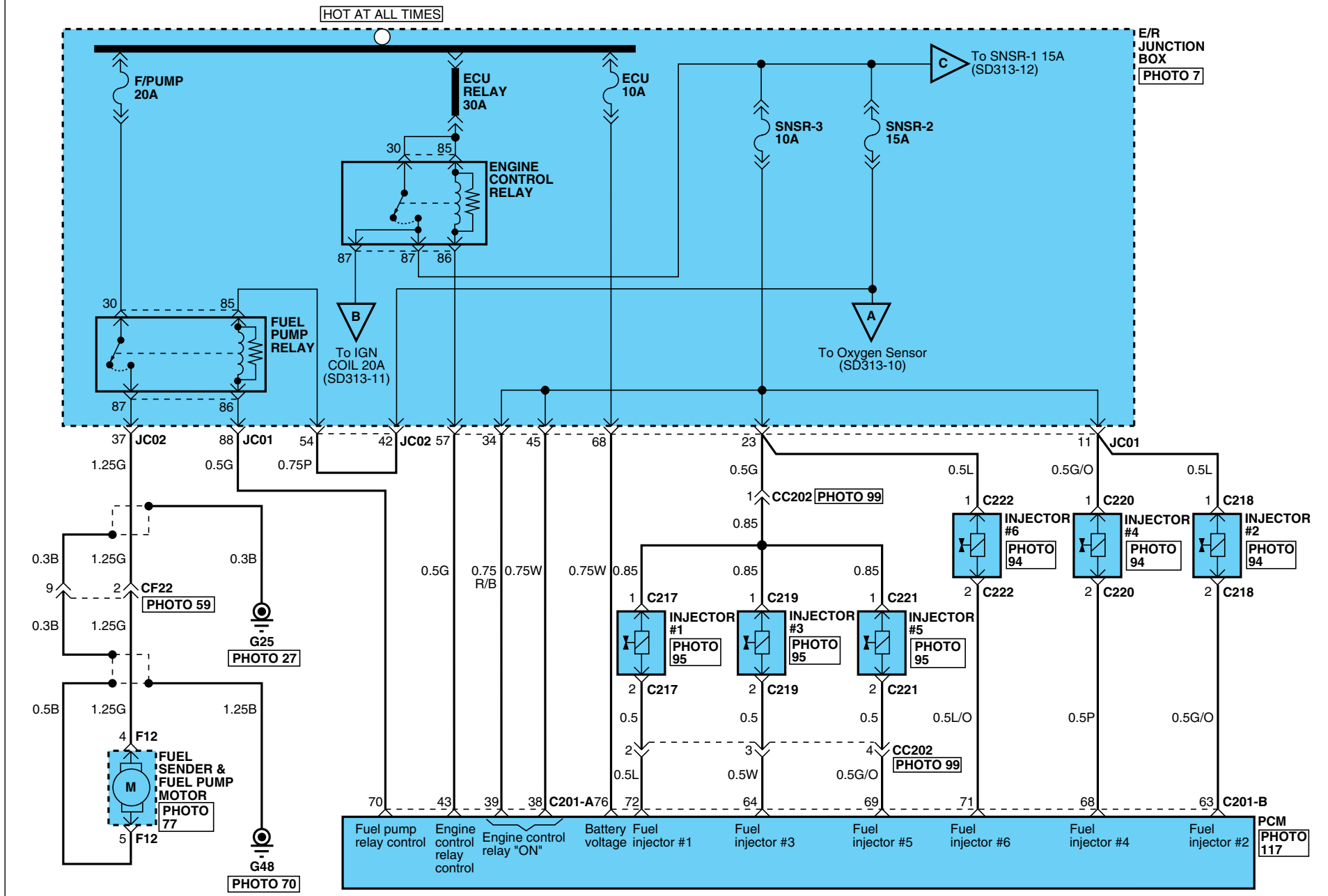



# MFI CONTROL SYSTEM

## MFI Control System (G6EA-GSL 2.7L) (2)

SD313-10

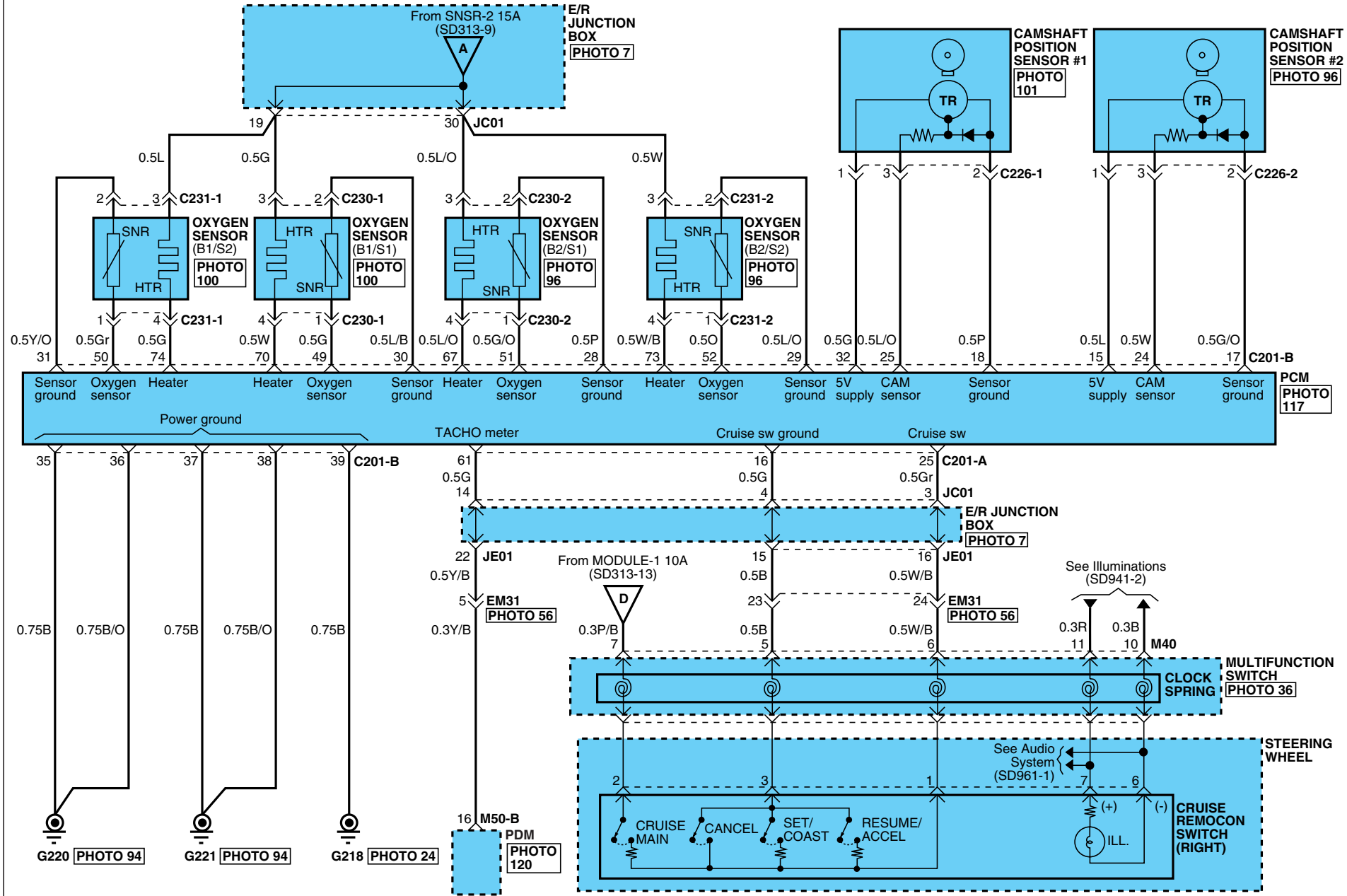

# MFI CONTROL SYSTEM

## MFI Control System (G6EA-GSL 2.7L) (3)

SD313-11

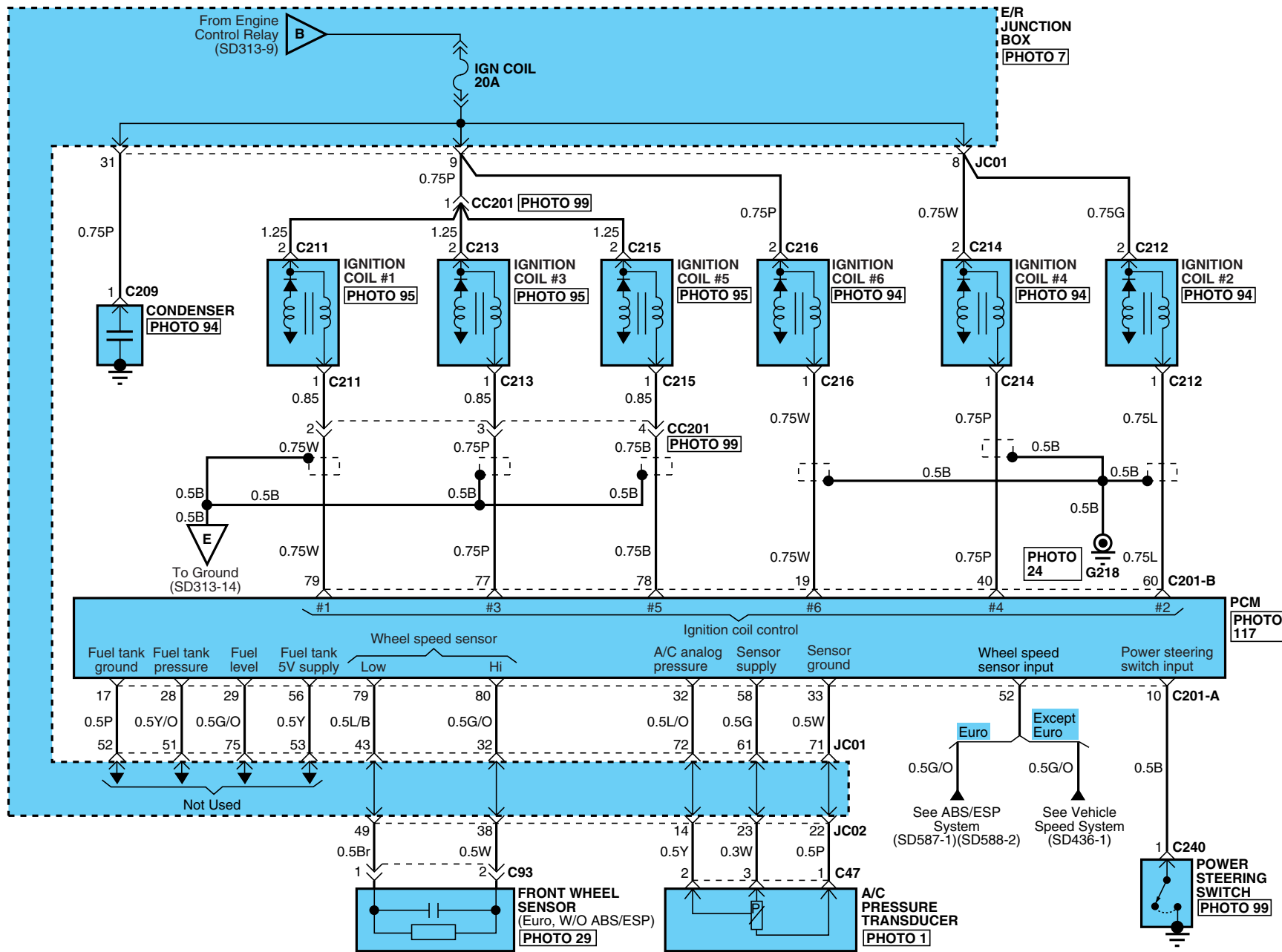

# MFI CONTROL SYSTEM

## MFI Control System (G6EA-GSL 2.7L) (4)

SD313-12

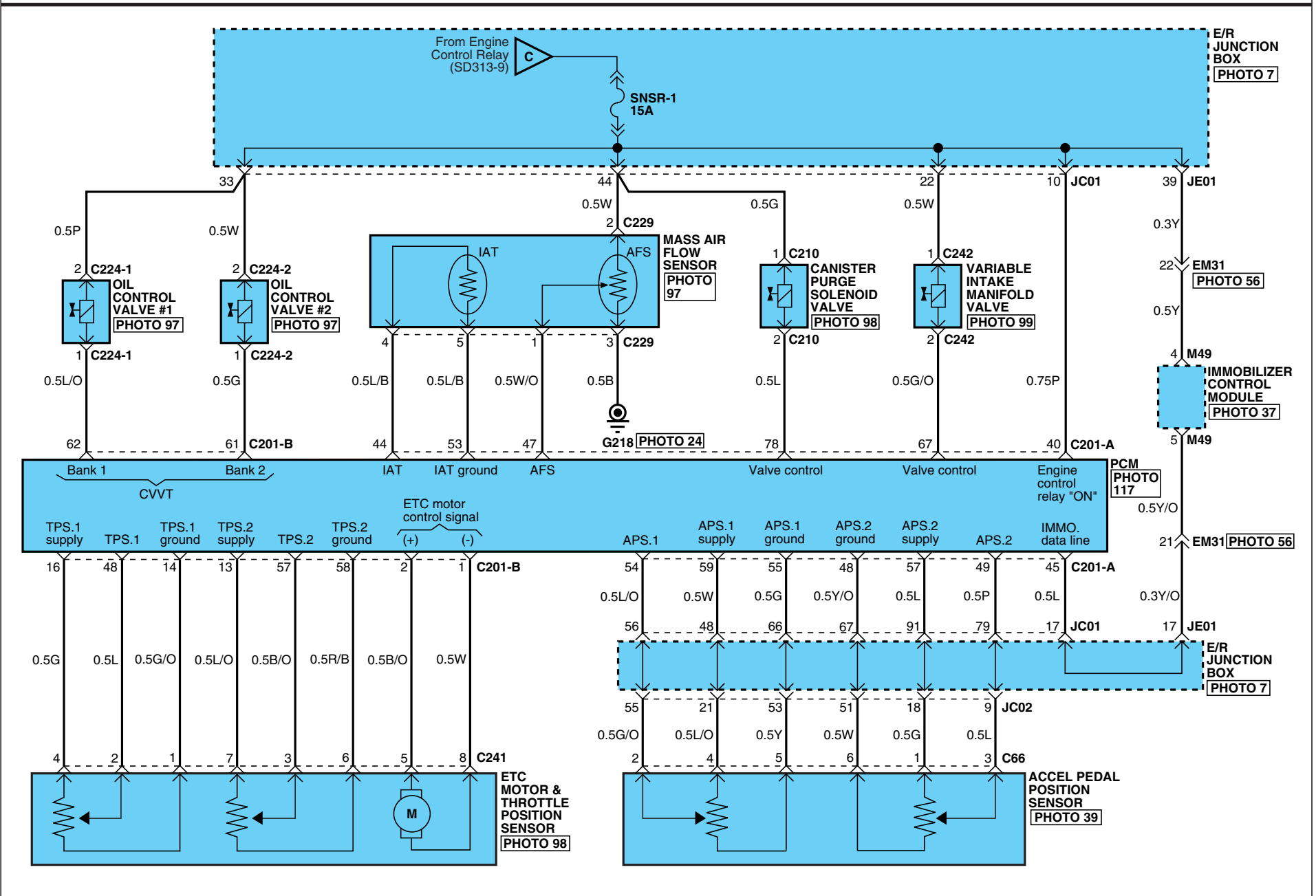

# MFI CONTROL SYSTEM

## MFI Control System (G6EA-GSL 2.7L) (5)

SD313-13

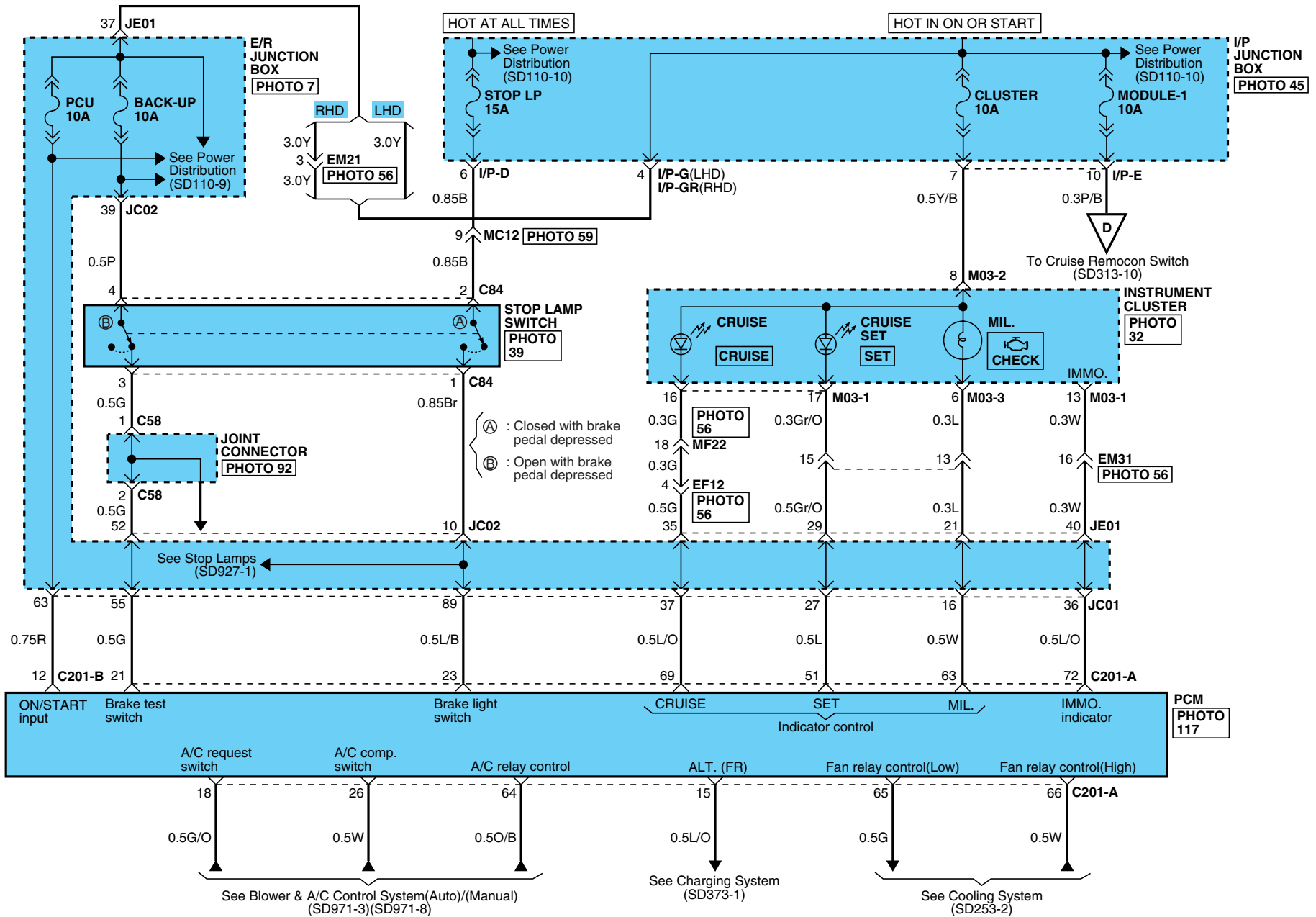

# MFI CONTROL SYSTEM

## MFI Control System (G6E-GSL 2.7L) (6)

SD313-14

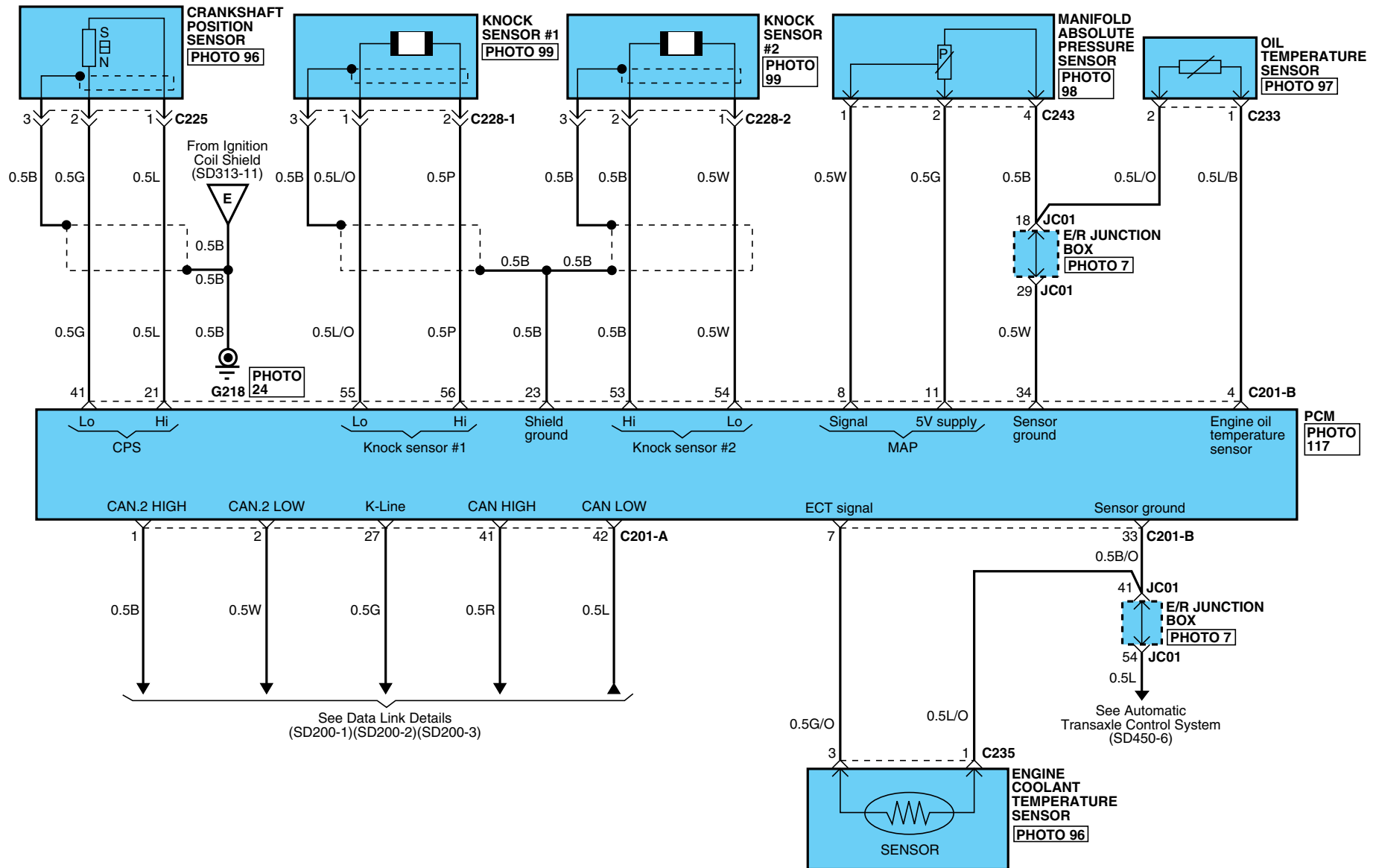

# MFI CONTROL SYSTEM

## MFI Control System (G6EA-GSL 2.7L) (7)

SD313-15

**C47**

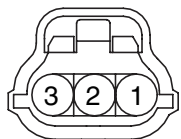

KET\_040WP\_03F\_B

**C66**

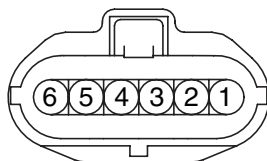

AMP\_070WP\_06F\_B

**C84**

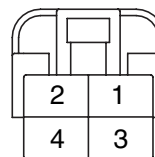

KET\_250DL\_04F\_W

**C93**

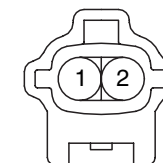

KET\_090IWP\_02M\_B

**C201-A**

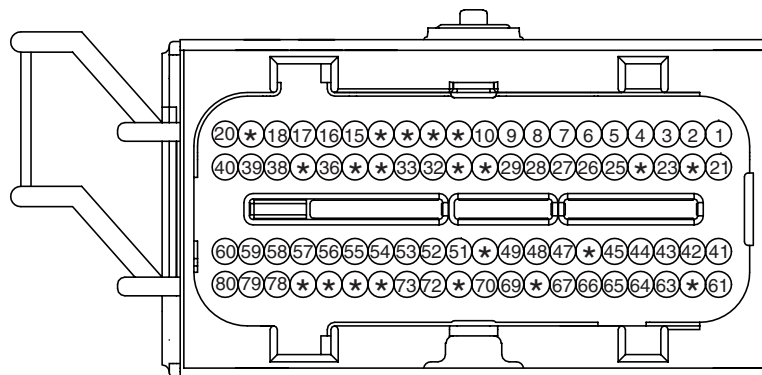

PKD\_ECU\_80F\_GR\_1

**C201-B**

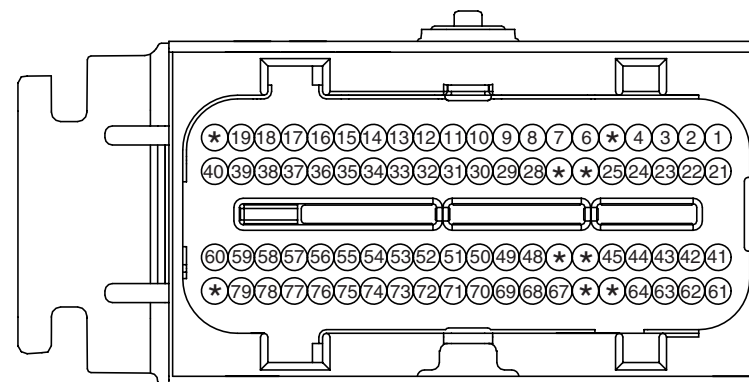

PKD\_ECU\_80F\_B\_2

**C209**

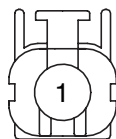

KET\_58X\_01F\_B

**C210**

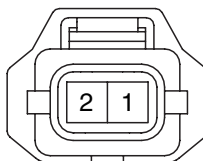

AMP\_2.8WP\_02F\_B

**C211/C213/C215**



MLX\_090CIGAR\_02F\_B

**C212/C214/C216**



MLX\_090CIGAR\_02F\_B

**C217/C219/C221**

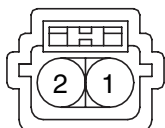

KUM\_NDWP\_02F\_B

**C218/C220/C222**

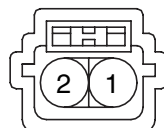

KUM\_NDWP\_02F\_B

**C224-1**

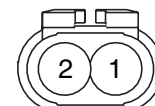

PKD\_GT150\_02F\_GR\_1

**C224-2**







PKD\_GT150\_02F\_B\_1

# MFI CONTROL SYSTEM

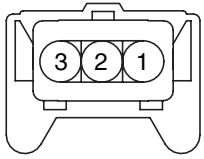
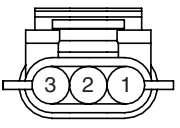
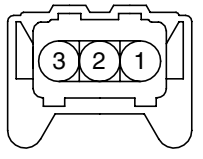
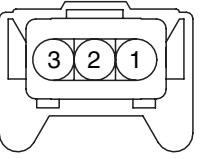
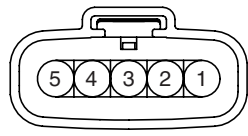
## MFI Control System (G6EA-GSL 2.7L) (8)

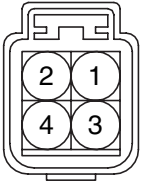
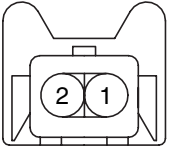
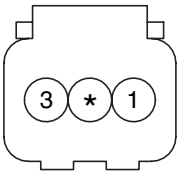
SD313-16

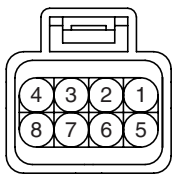
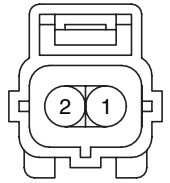
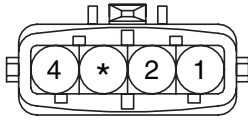
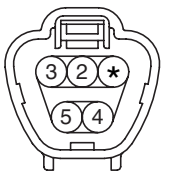
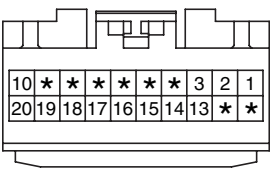
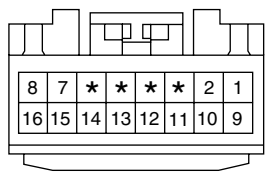
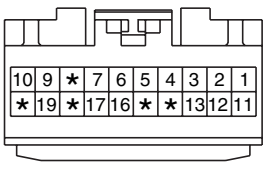
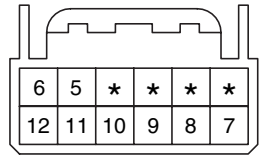
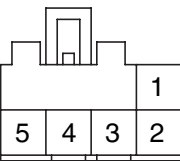
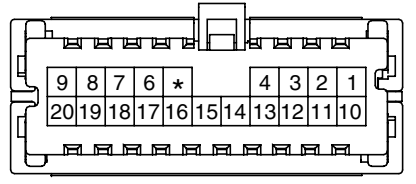
<p><b>C225</b></p>  <p>AMP_JPT_03F_B_S1</p>	<p><b>C226-1/2</b></p>  <p>PKD_150WP_03F_B_L</p>	<p><b>C228-1</b></p>  <p>AMP_JPT_03F_Gr_R2</p>	<p><b>C228-2</b></p>  <p>AMP_JPT_03F_B_S2</p>
<p><b>C229</b></p>  <p>PKD_GT150_05F_B</p>	<p><b>C230-1/2</b></p>  <p>KUM_KNWMP_04F_B</p>	<p><b>C231-1/2</b></p>  <p>KUM_NMWP_04F_Gr</p>	<p><b>C233</b></p>  <p>AMP_JPT_02F_B</p>
<p><b>C235</b></p>  <p>KUM_WTS_03F_B</p>	<p><b>C240</b></p>  <p>AMP_EJWP_01F_B</p>	<p><b>C241</b></p>  <p>PKD_GT150_08F_B</p>	<p><b>C242</b></p>  <p>AMP_EJWP_02F_B</p>
<p><b>C243</b></p>  <p>AMP_JPT_04F_B_BOSCH</p>	<p><b>F12</b></p>  <p>KET_090IWP_05F_Gr_2</p>	<p><b>M03-1</b></p>  <p>MLX_040III_20F_Gr</p>	<p><b>M03-2</b></p>  <p>MLX_040III_16F_Gr</p>
<p><b>M03-3</b></p>  <p>MLX_040III_20F_Gr</p>	<p><b>M40</b></p>  <p>AMP_Q25_12F_W</p>	<p><b>M49</b></p>  <p>KUM_CDR_05F_W</p>	<p><b>M50-B</b></p>  <p>KET_040III_20F</p>

MFI Control System (D4EA-DSL 2.0L) (1)

SD313-17

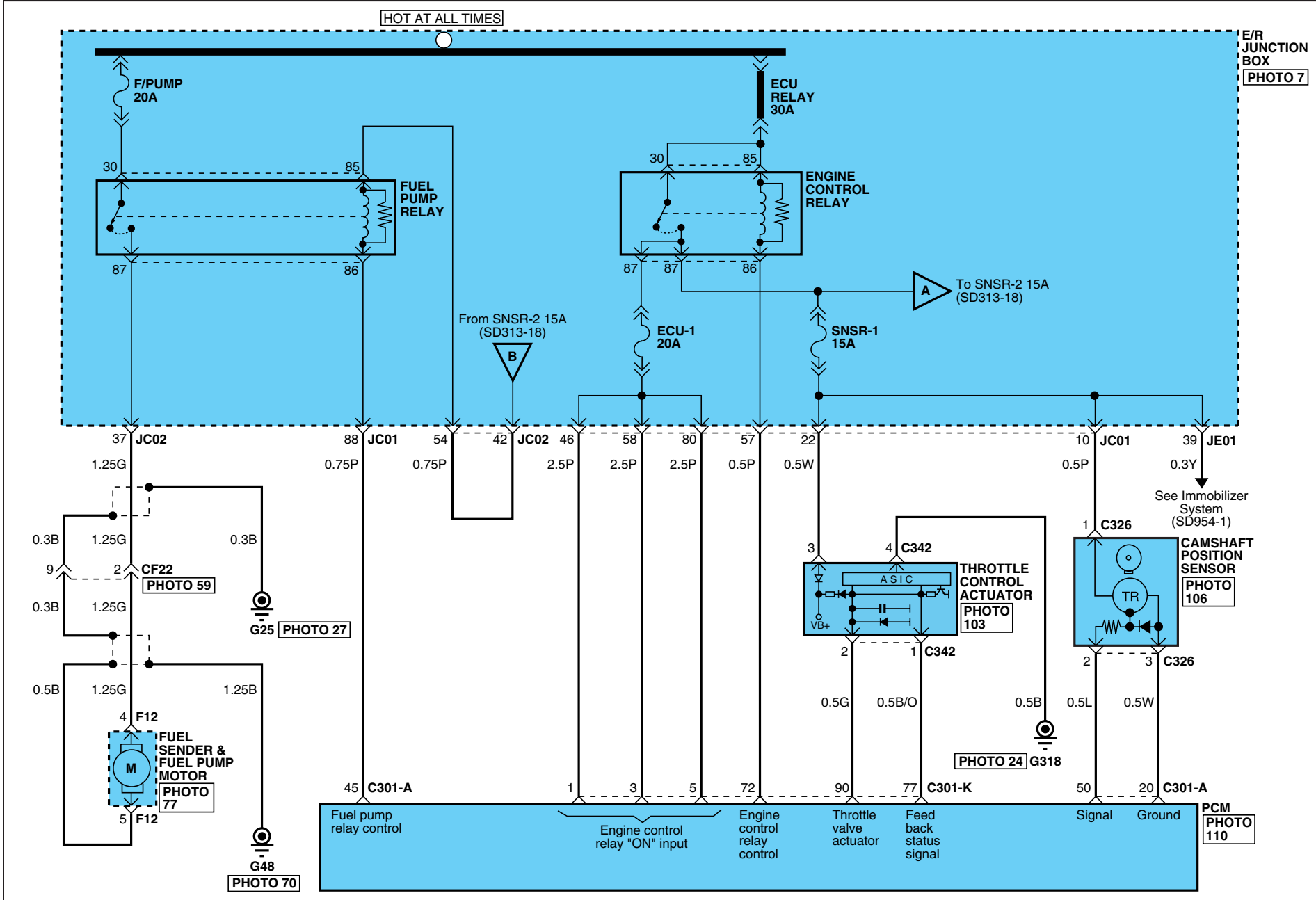



# MFI CONTROL SYSTEM

## MFI Control System (D4EA-DSL 2.0L) (2)

SD313-18

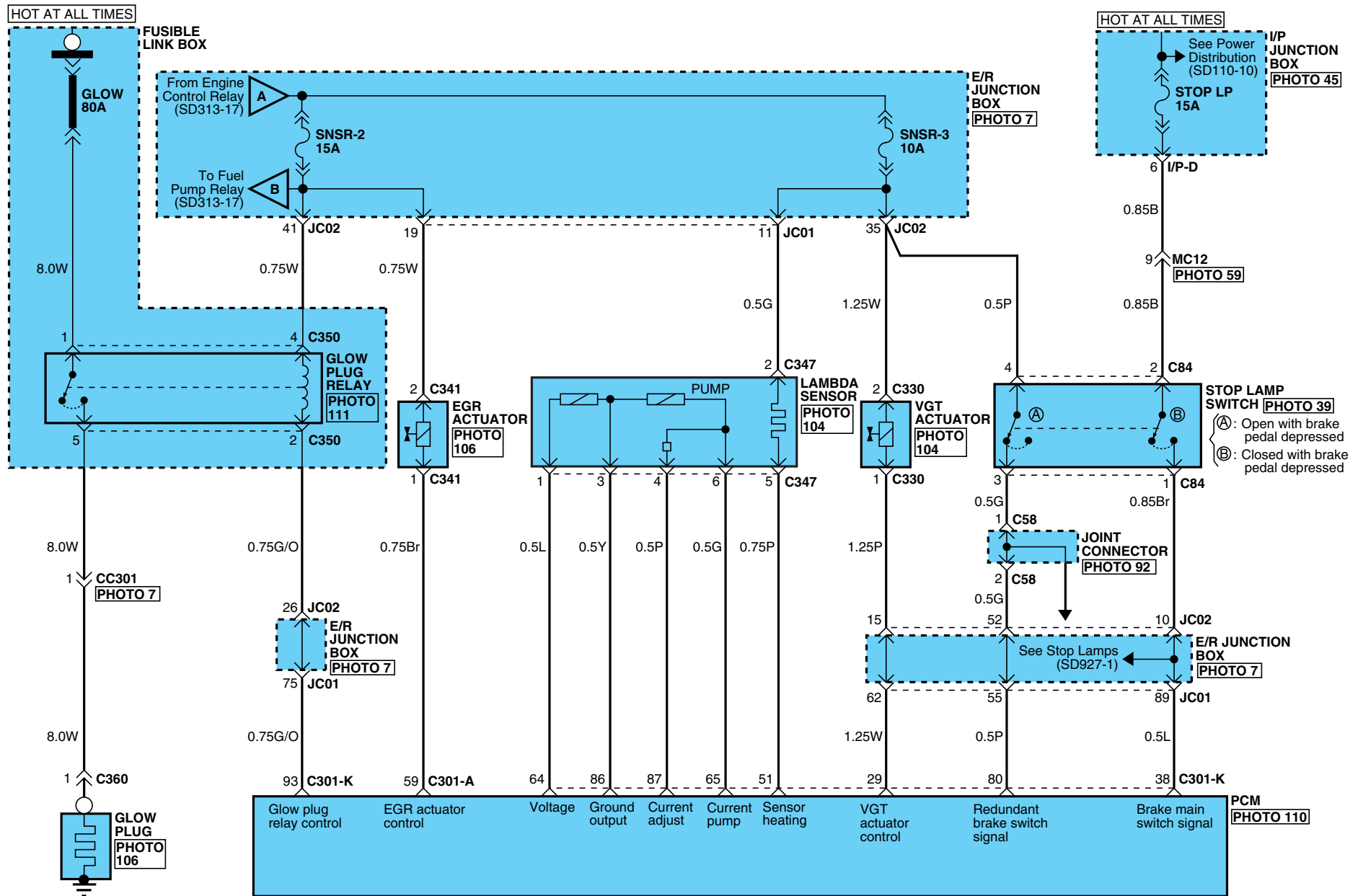

# MFI CONTROL SYSTEM

## MFI Control System (D4EA-DSL 2.0L) (3)

SD313-19

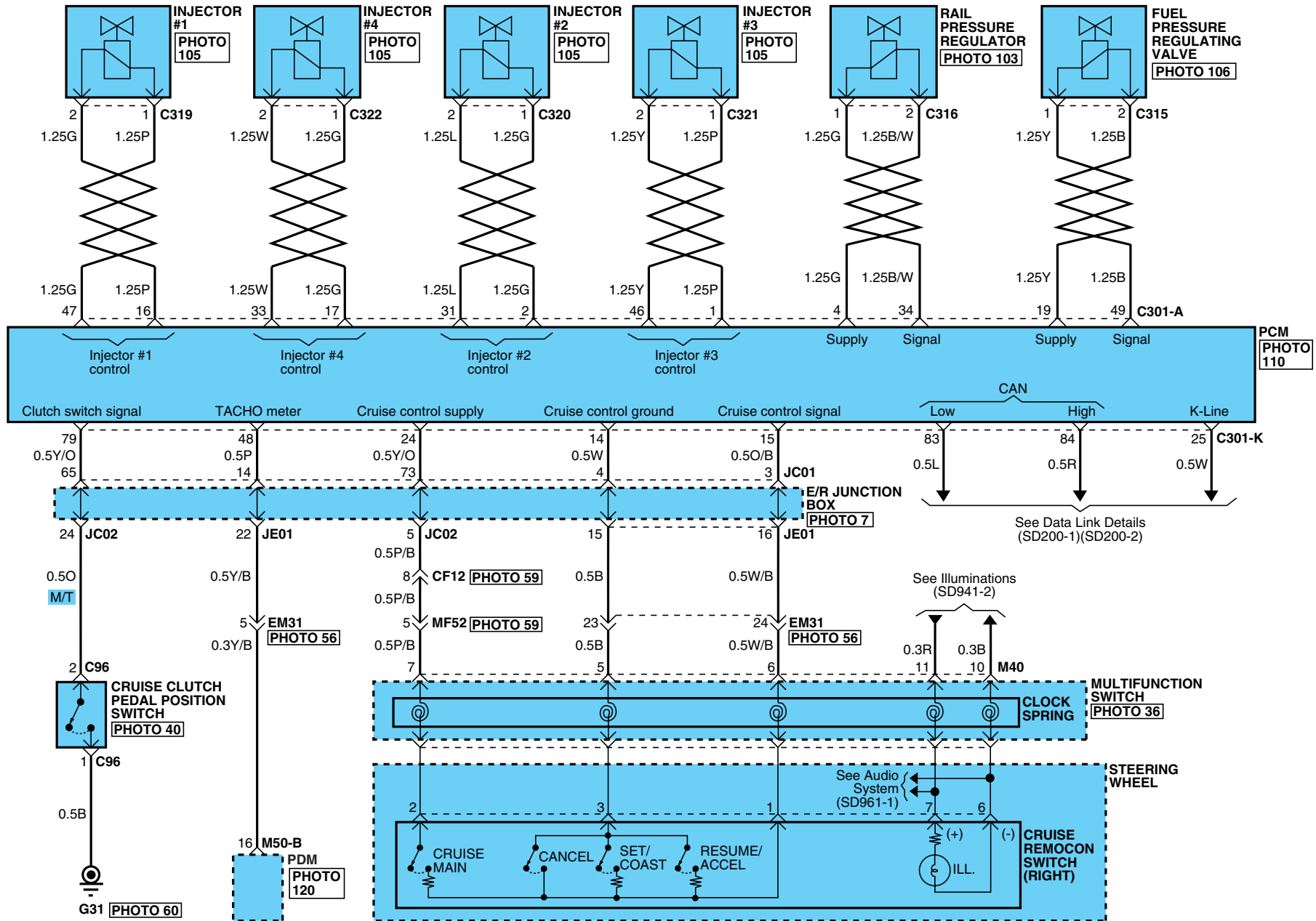

# MFI CONTROL SYSTEM

## MFI Control System (D4EA-DSL 2.0L) (4)

SD313-20

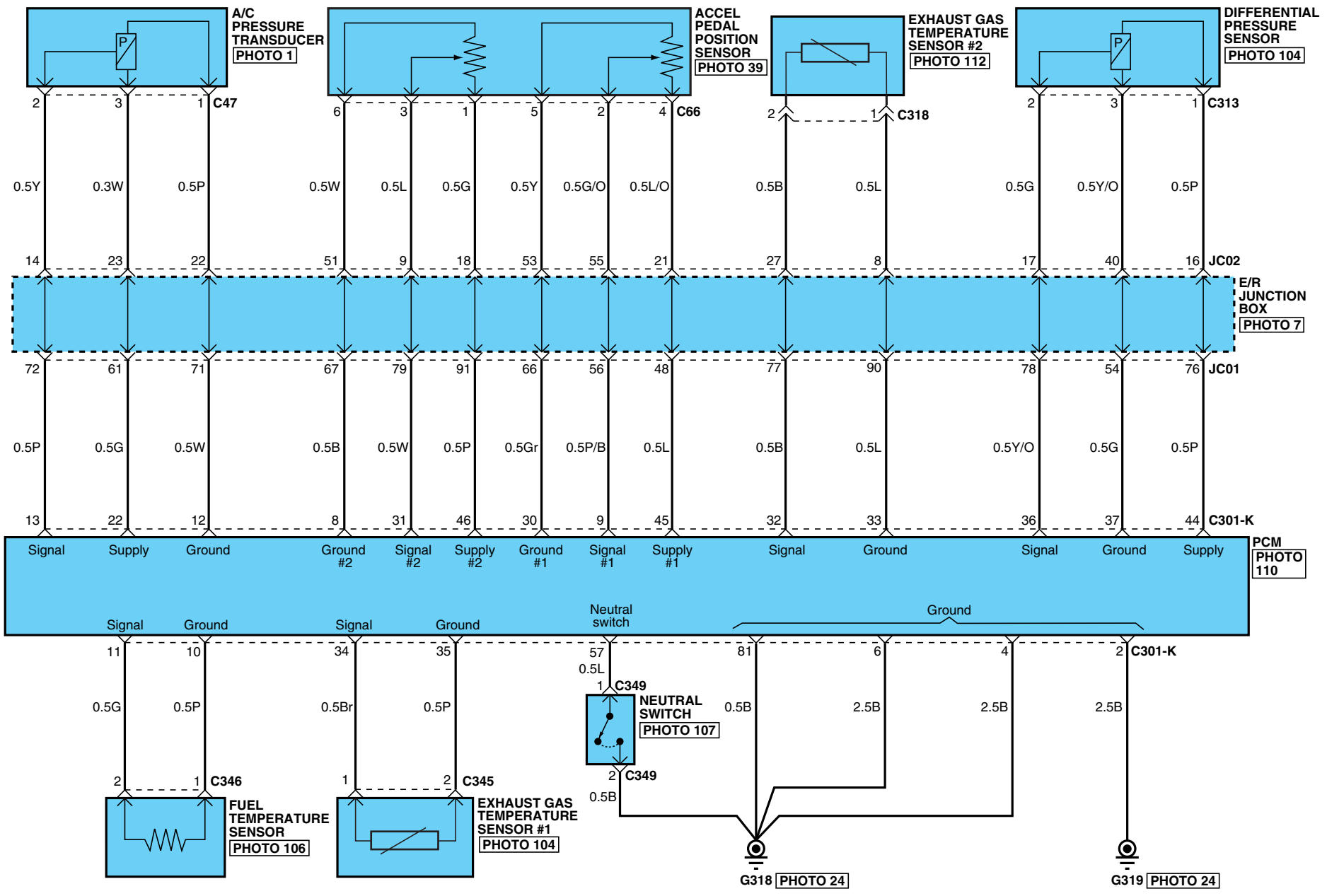

# MFI CONTROL SYSTEM

## MFI Control System (D4EA-DSL 2.0L) (5)

SD313-21

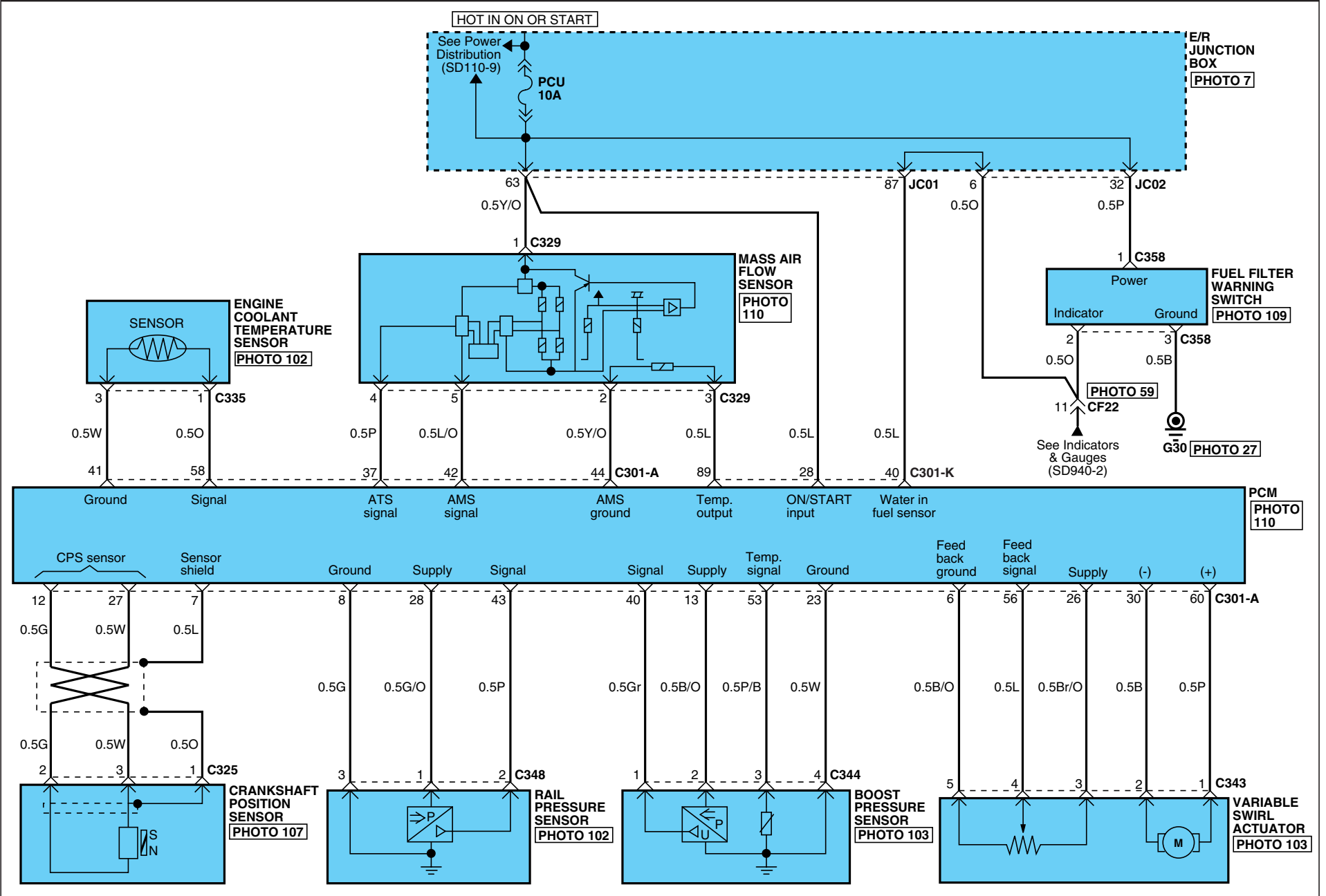

# MFI CONTROL SYSTEM

## MFI Control System (D4EA-DSL 2.0L) (6)

SD313-22

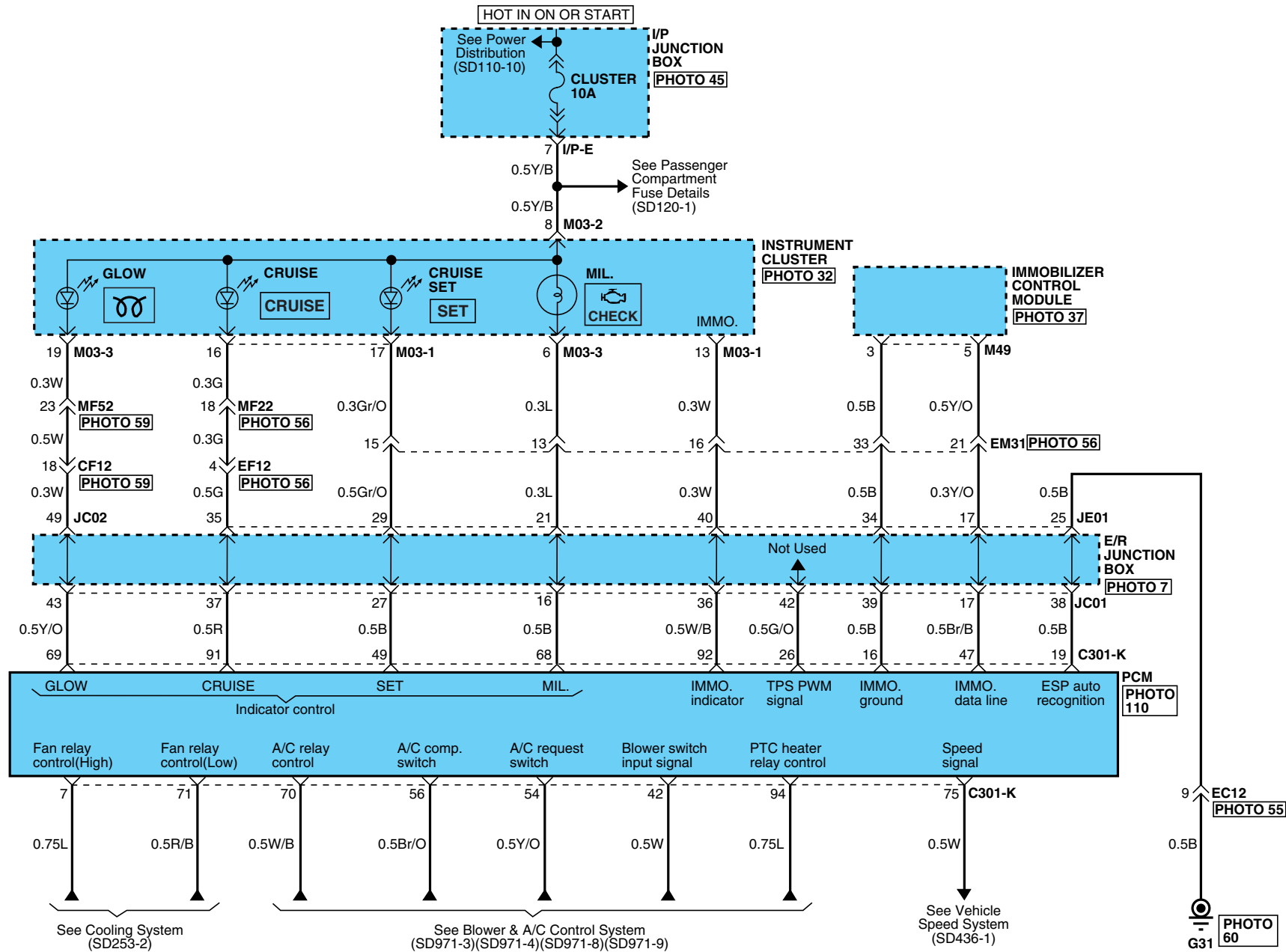

# MFI CONTROL SYSTEM

## MFI Control System (D4EA-DSL 2.0L) (7)

SD313-23

**C47**

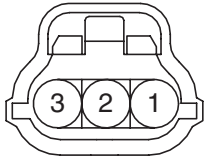

KET\_040WP\_03F\_B

**C66**

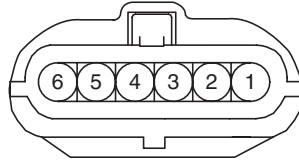

AMP\_070WP\_06F\_B

**C84**

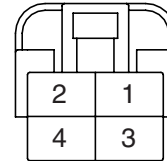

KET\_250DL\_04F\_W

**C96**

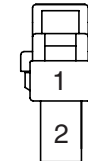

KET\_250DL\_02F\_W

**C301-A**

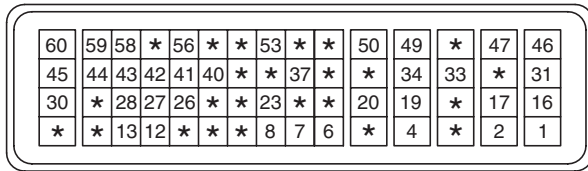

AMP\_TCU\_60F\_B\_SIE

**C301-K**

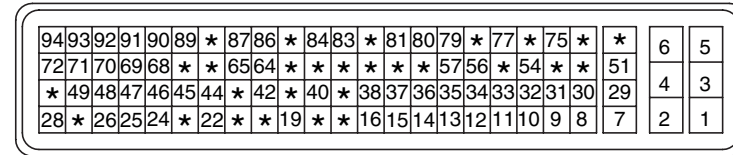

AMP\_PCU\_94F\_B\_SIE

**C313**

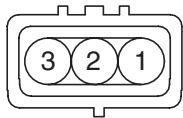

SUM\_WP\_03F\_B

**C315**

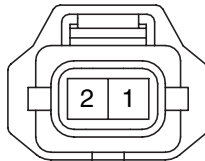

AMP\_INJ\_02F\_B

**C316**

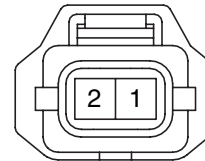

AMP\_INJ\_02F\_B

**C318**

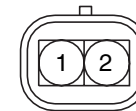

SUM\_SENSOR\_02M\_W

**C319/C320/C321/C322**

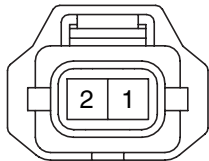

AMP\_INJ\_02F\_B

**C325**



AMP\_EMS\_03F\_B\_1

**C326**



BSH\_EMS\_03F\_B\_1

**C329**

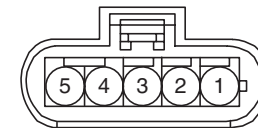

HSM\_SENSOR\_05F\_B

**C330**

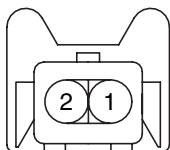

AMP\_JPT\_02F\_B

**C335**

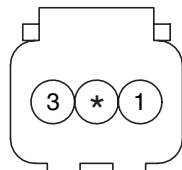

KUM\_WTS\_03F\_B

**C341**

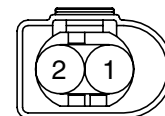

AMP\_INJ\_02F\_B

**C342**

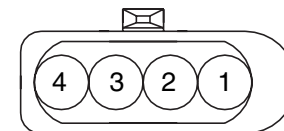





FEP\_NFDSL\_04F\_N

**MFI CONTROL SYSTEM**

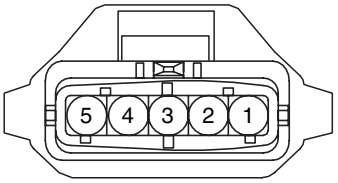
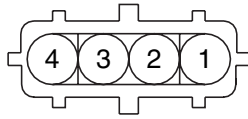
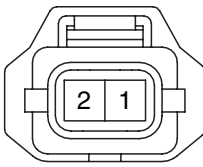
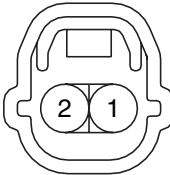
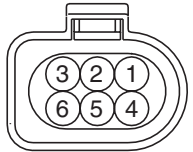
**MFI Control System (D4EA-DSL 2.0L) (8)**

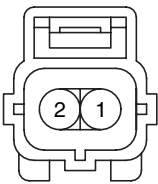
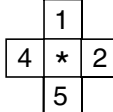
**SD313-24**

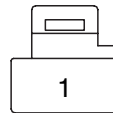
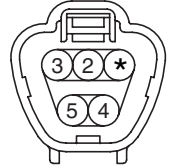
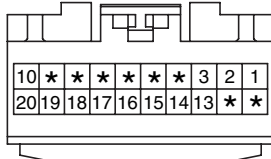
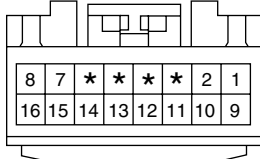
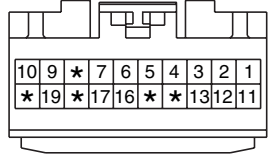
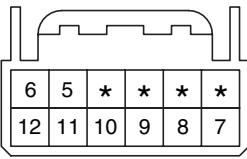
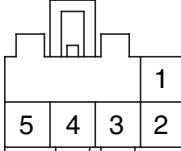
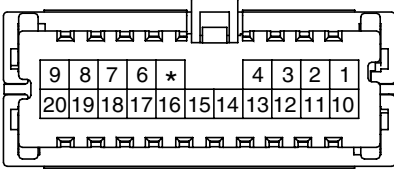
<p><b>C343</b></p>  <p>AMP_JPT_05F_B_SET</p>	<p><b>C344</b></p>  <p>BSH_SENSOR_04F_B_DSL</p>	<p><b>C345</b></p>  <p>AMP_INJ_02F_B</p>	<p><b>C346</b></p>  <p>KET_SSD_02F_B</p>
<p><b>C347</b></p>  <p>BSH_SENSOR_06F_B_NF</p>	<p><b>C348</b></p>  <p>BSH_EMS_03F_B_2</p>	<p><b>C349</b></p>  <p>AMP_EJWP_02F_B</p>	<p><b>C350</b></p>  <p>CR05F019</p>
<p><b>C358</b></p>  <p>AMP_090WP_03F_B</p>	<p><b>C360</b></p>  <p>KET_58L_01F_B</p>	<p><b>F12</b></p>  <p>KET_090IWP_05F_Gr_2</p>	<p><b>M03-1</b></p>  <p>MLX_040III_20F_Gr</p>
<p><b>M03-2</b></p>  <p>MLX_040III_16F_Gr</p>	<p><b>M03-3</b></p>  <p>MLX_040III_20F_Gr</p>	<p><b>M40</b></p>  <p>AMP_025_12F_W</p>	<p><b>M49</b></p>  <p>KUM_CDR_05F_W</p>
<p><b>M50-B</b></p>  <p>KET_040III_20F</p>	<p><b>BLANK</b></p>	<p><b>BLANK</b></p>	<p><b>BLANK</b></p>

Starting System (1)

SD360-1

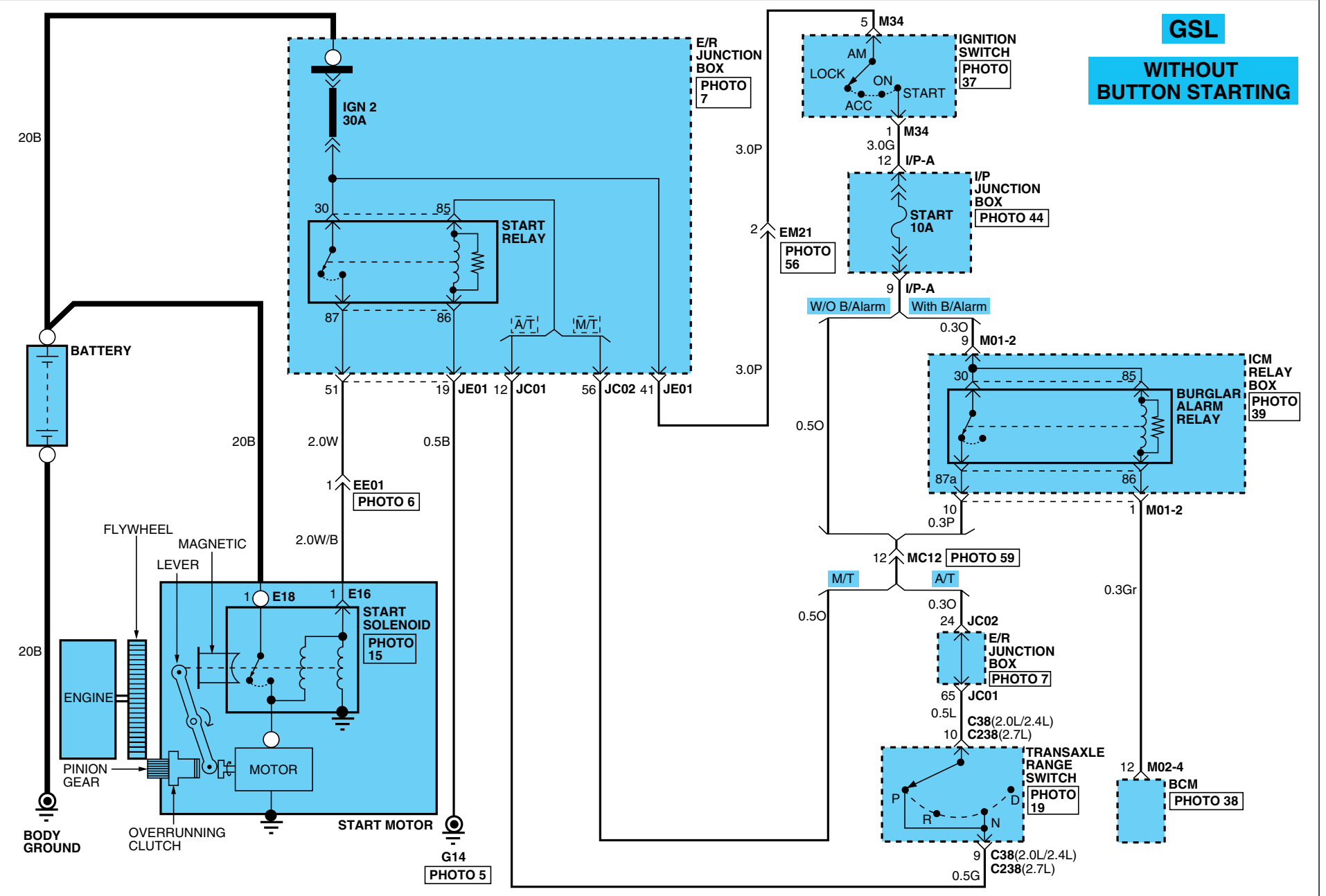



# STARTING SYSTEM

## Starting System (2)

SD360-2

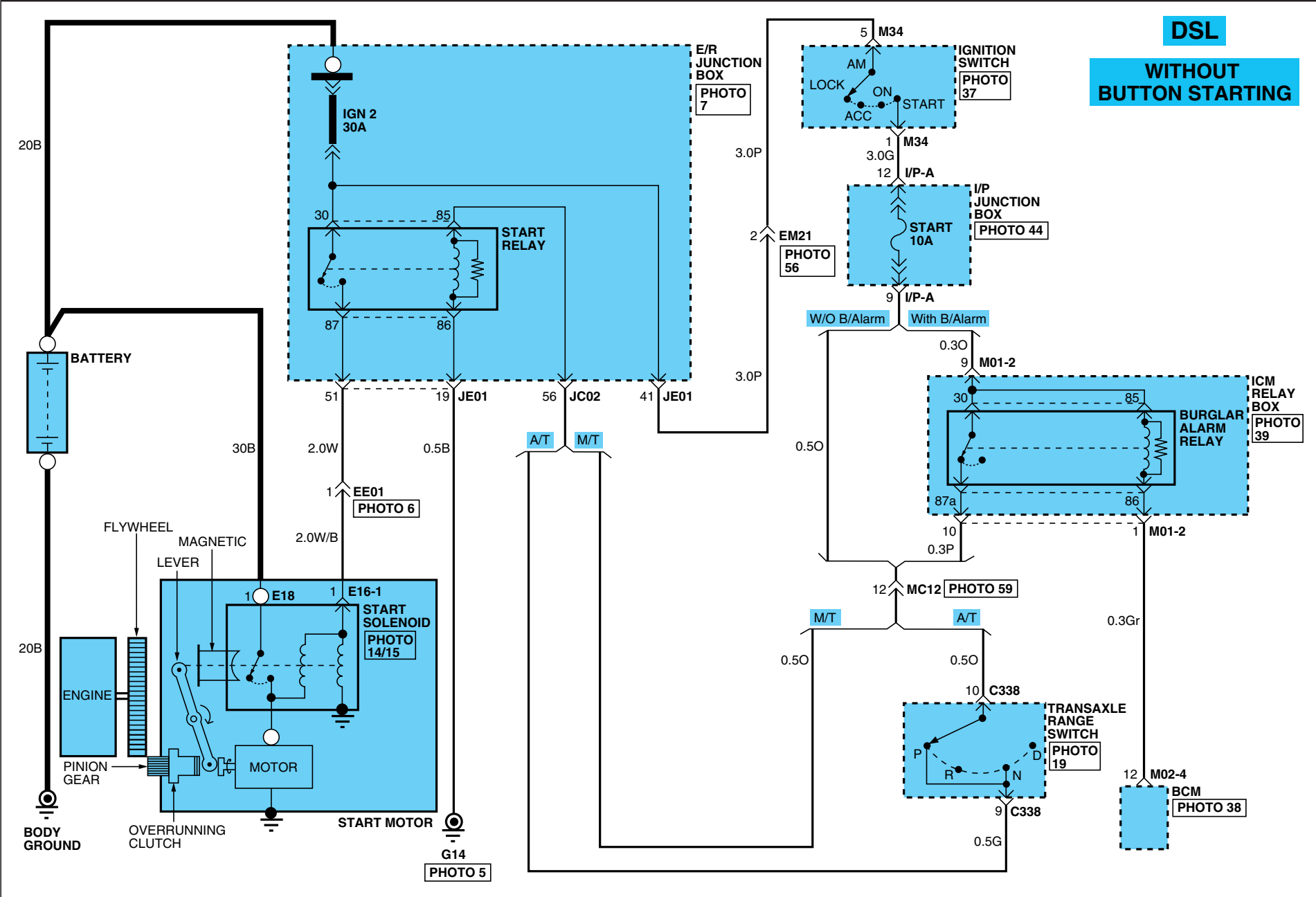

**DSL**  
**WITHOUT**  
**BUTTON**  
**STARTING**

# STARTING SYSTEM

## Starting System (3)

SD360-3

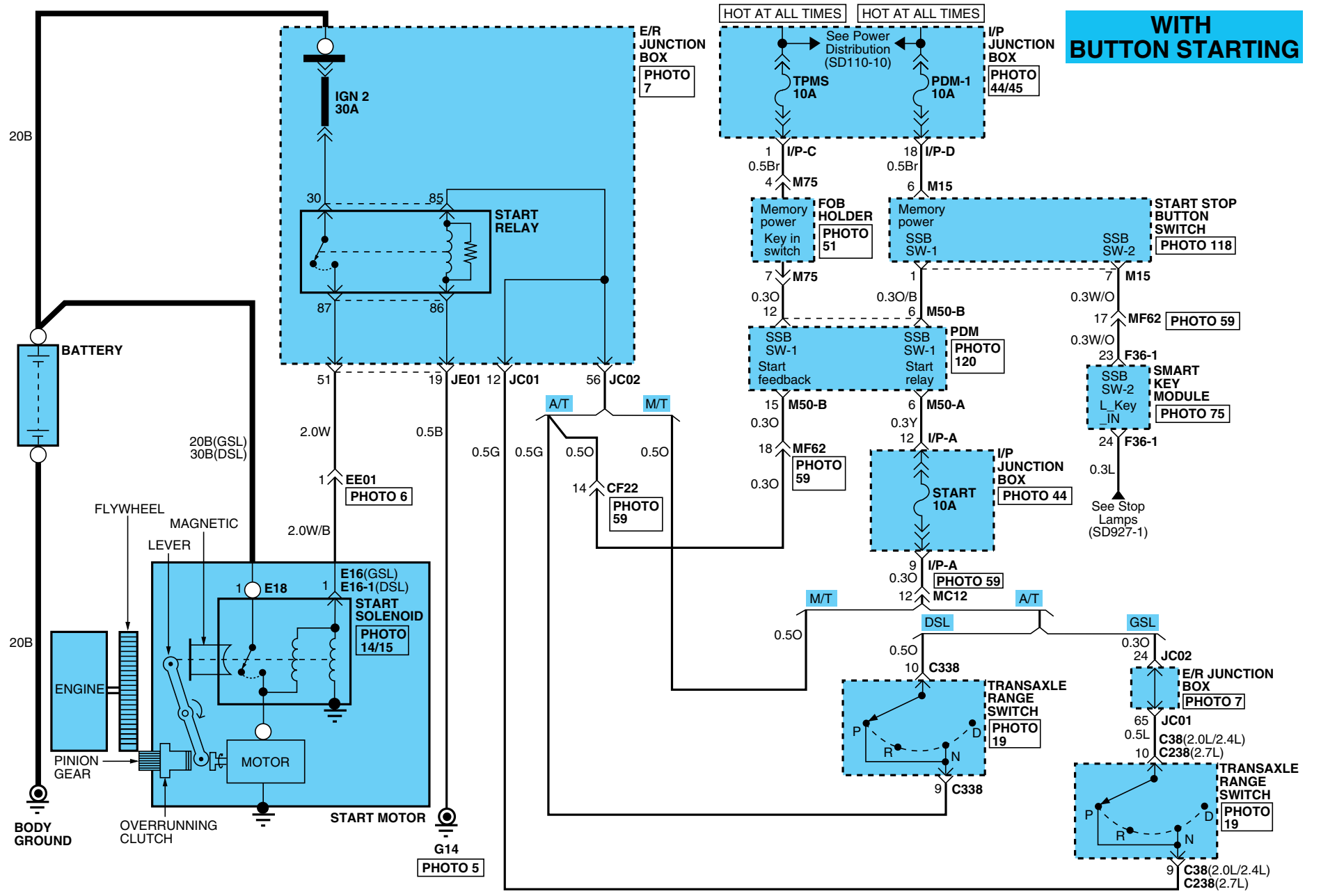

# STARTING SYSTEM

## Starting System (4)

SD360-4

**C38/C238/C338**



KET\_SSD\_10F\_B\_A

**E16**

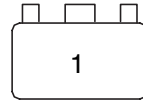

KET\_250WP\_01F\_Gr

**E16-1**

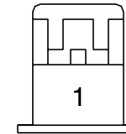

KUM\_DSD\_1F(B)

**E18**

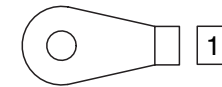

**M01-2**

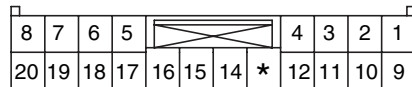

AMP\_0925\_20F\_W

**M02-4**

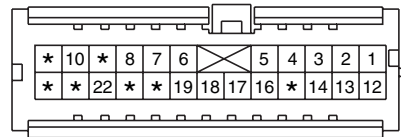

KET\_040III\_24F\_Gr

**M15**

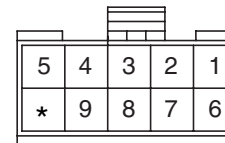

MLX\_025\_10F\_B

**M34**

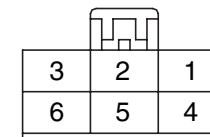

KUM\_DSD\_06F\_B

**M50-A**

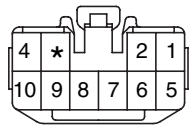

KET\_090II\_10F\_B

**M50-B**

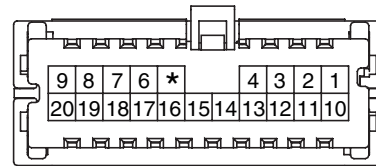

KET\_040III\_20F\_W

**M75**

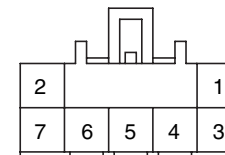

KUM\_CDR\_07F

**BLANK**

Fuel Filter Heating System (D4EA-DSL 2.0L) (1)

SD361-1

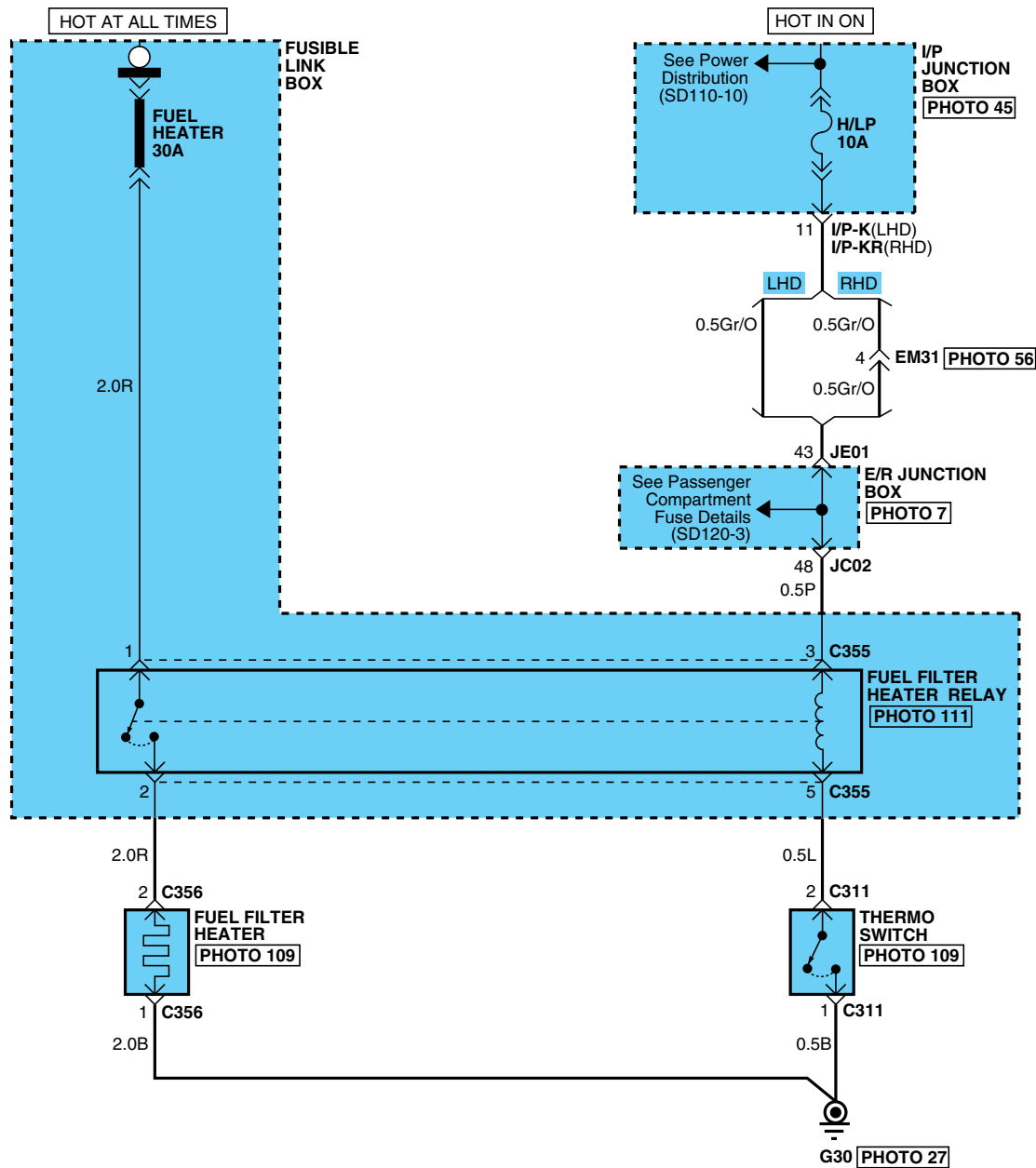

# FUEL FILTER HEATING SYSTEM

Fuel Filter Heating System (D4EA-DSL 2.0L) (2)

SD361-2

C311



KUM\_NMWP\_02F\_B

C355

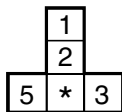

CR05F011

C356

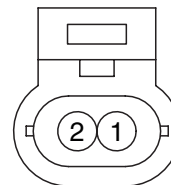

PKD\_280WP\_02F\_B\_1

BLANK

Charging System (1)

SD373-1

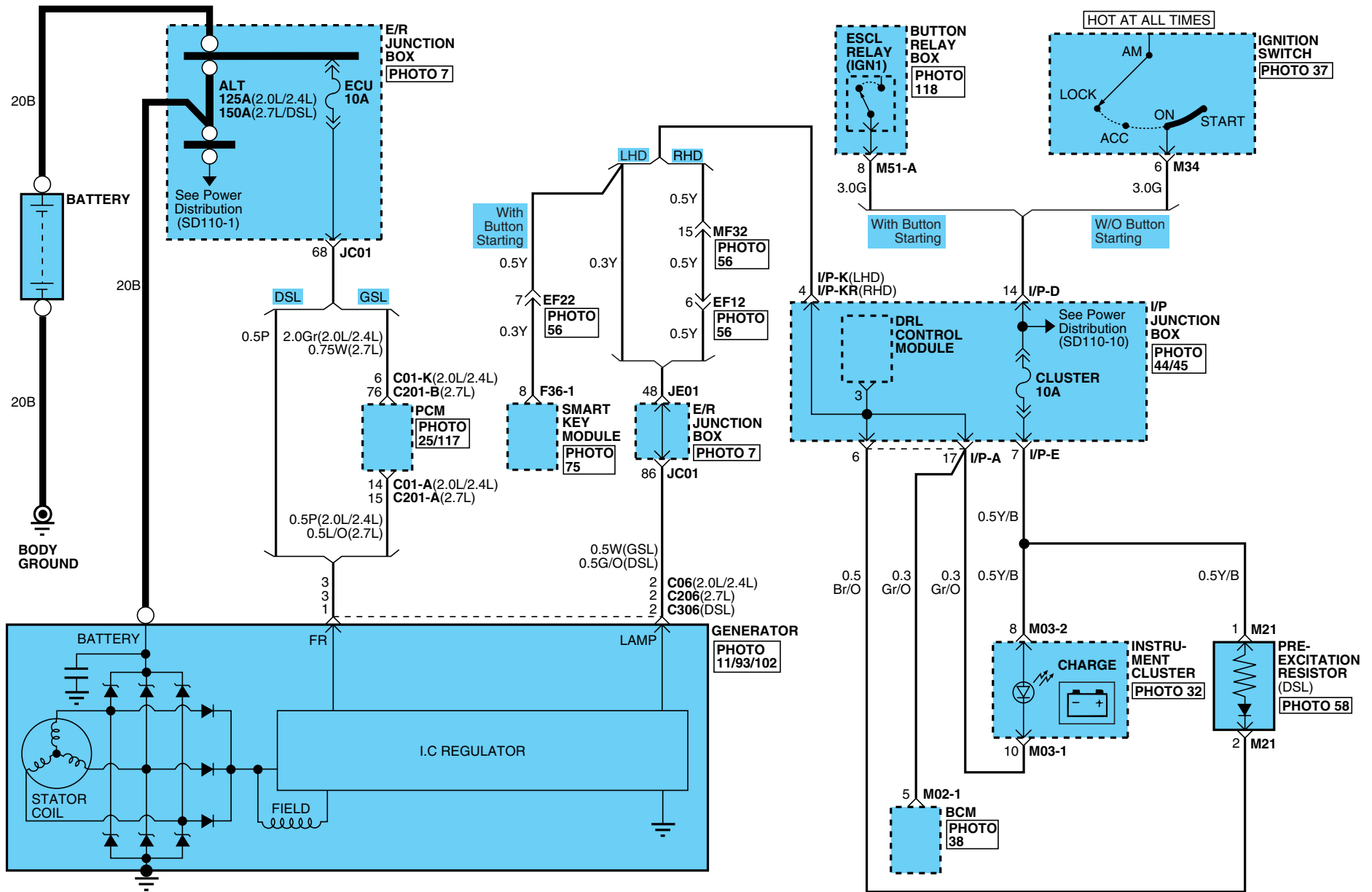

# CHARGING SYSTEM

## Charging System (2)

SD373-2

**C01-A**

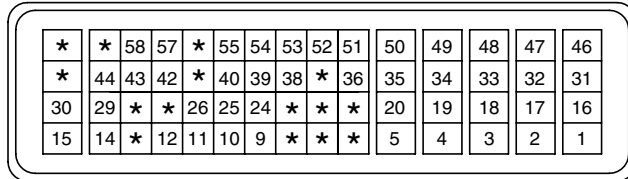

AMP\_TCU\_60F\_B\_SIE

**C01-K**

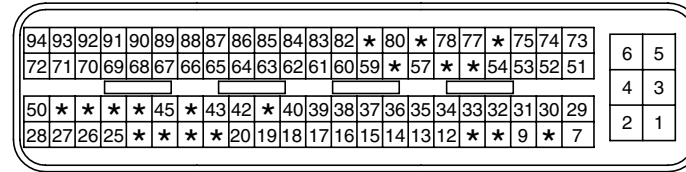

AMP\_PCU\_94F\_B\_SIE

**C201-A**

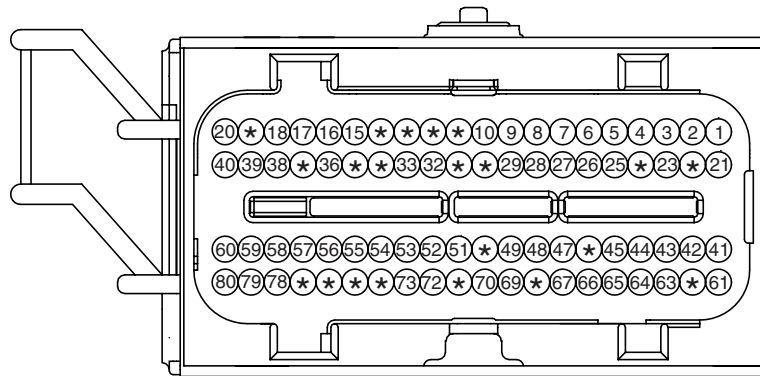

PKD\_ECU\_80F\_GR\_1

**C201-B**

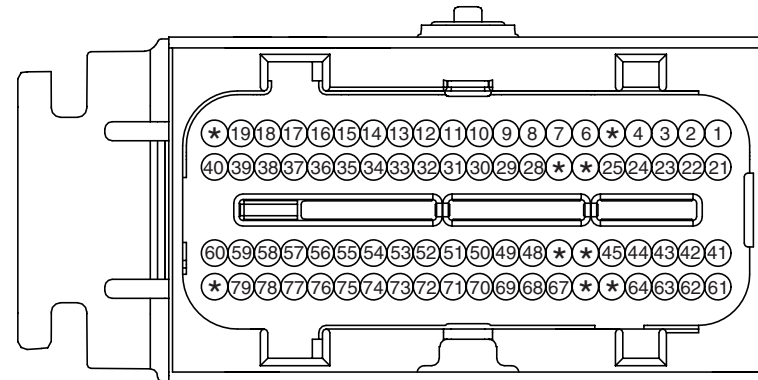

PKD\_ECU\_80F\_B\_2

**C06**

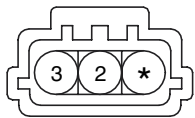

KET\_090IWP\_03F\_B

**C206**

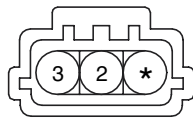

KET\_090IWP\_03F\_B

**C306**

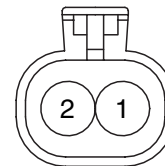

KET\_58X\_02F\_B

**F36-1**

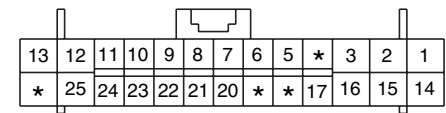

AMP\_0407\_26F\_W\_HD

**M02-1**

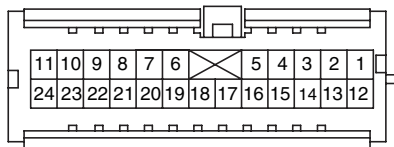

KET\_040III\_24F\_W

**M03-2**

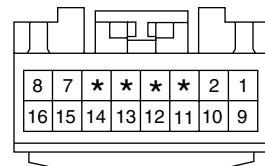

MLX\_040III\_16F\_Gr

**M03-3**

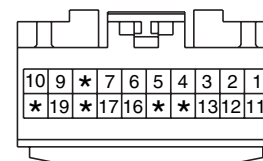

MLX\_040III\_20F\_Gr

**M21**

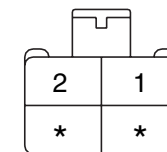

KET\_250\_04F\_W

# CHARGING SYSTEM

## Charging System (3)

SD373-3

M34

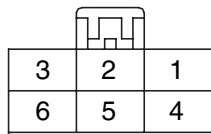

KUM\_DSD\_06F\_B

M51-A

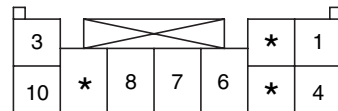

AMP\_0925\_10F\_W

BLANK

BLANK



## CHARGING SYSTEM

Charging System (4)

SD373-4

MEMO

# VEHICLE SPEED SYSTEM

E5AC3D93

## Vehicle Speed System (1)

SD436-1

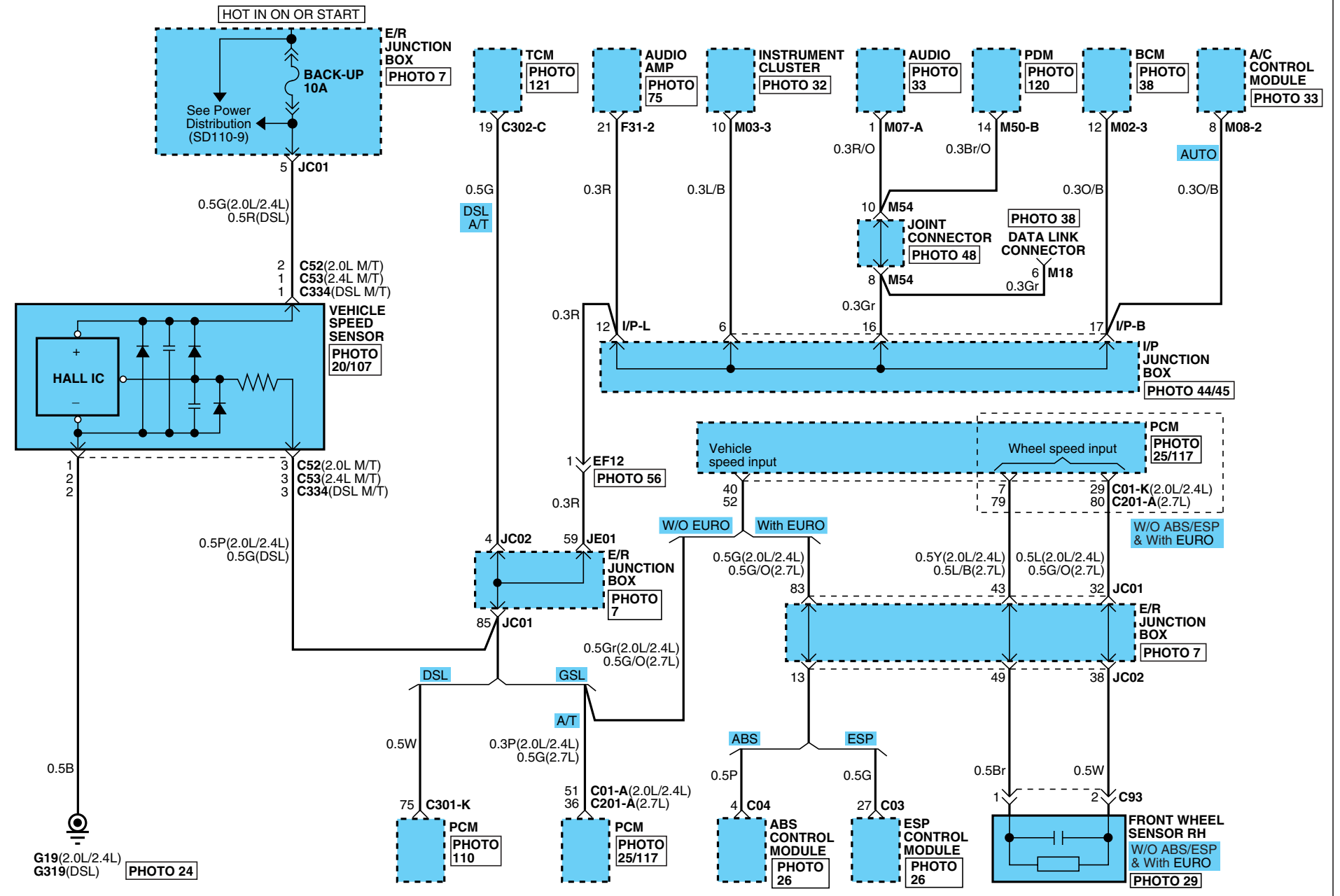

# VEHICLE SPEED SYSTEM

## Vehicle Speed System (2)

SD436-2

**C01-A**

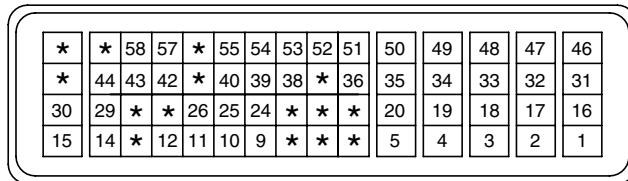

AMP\_TCU\_60F\_B\_SIE

**C01-K**

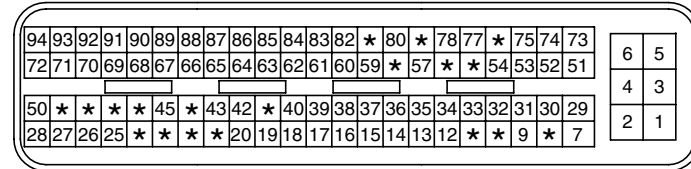

AMP\_PCU\_94F\_B\_SIE

**C03**

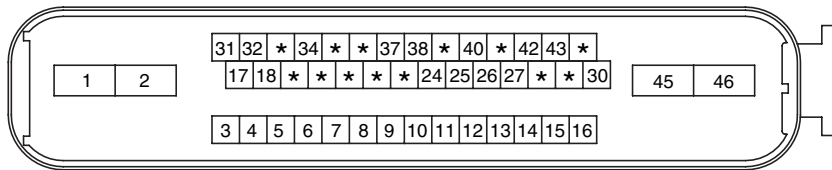

AMP\_ESP\_46F\_B

**C04**

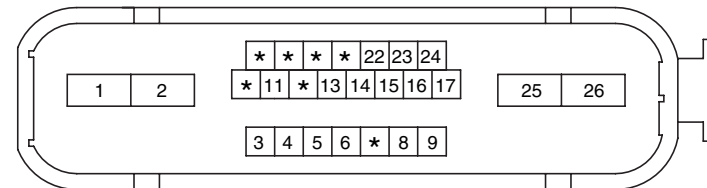

AMP\_ABS\_26F\_B

**C52**

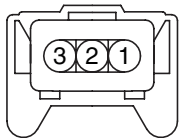

AMP\_JPT\_03F\_B\_S1

**C53**

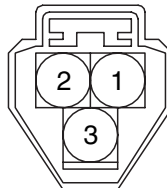

KUM\_NMWP\_03F\_B

**C201-A**

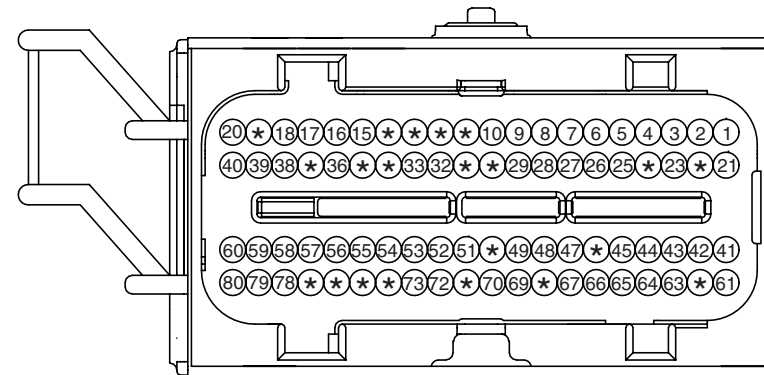

PKD\_ECU\_80F\_GR\_1

**C93**

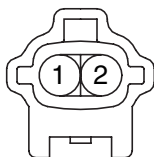

KET\_090IWP\_02M\_B

**C334**

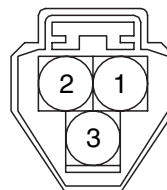

KUM\_NMWP\_03F\_B

**C301-K**

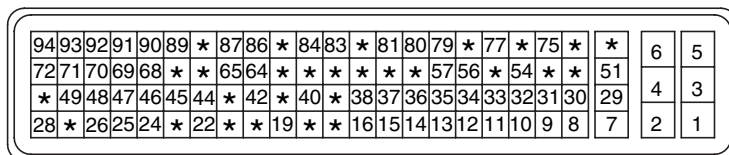

AMP\_PCU\_94F\_B\_SIE

**F31-2**

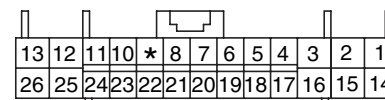

KET\_0407M11\_26F\_GR

**M02-3**

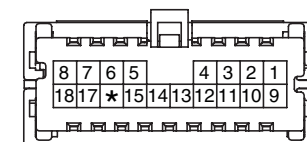

KET\_040III\_18F\_W

# VEHICLE SPEED SYSTEM

## Vehicle Speed System (3)

SD436-3

**M03-3**

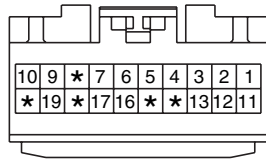

MLX\_040III\_20F\_Gr

**M07-A**

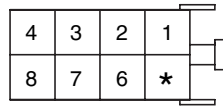

AMP\_JT\_08F\_Gr

**M08-2**

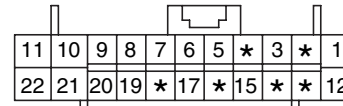

AMP\_0407\_22F\_W\_HD

**M18**

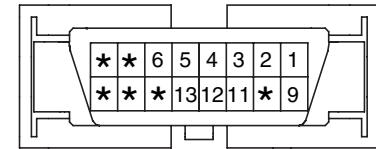

MLX\_OBDII\_16F\_B

**M50-B**

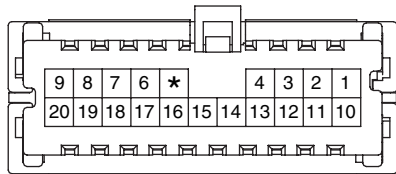

KET\_040III\_20F

**BLANK**

**BLANK**

**BLANK**

## VEHICLE SPEED SYSTEM

Vehicle Speed System (4)

SD436-4

MEMO

**Automatic Transaxle Control System (G4KD/G4KE-GSL 2.0L/2.4L) (1)**

**SD450-1**

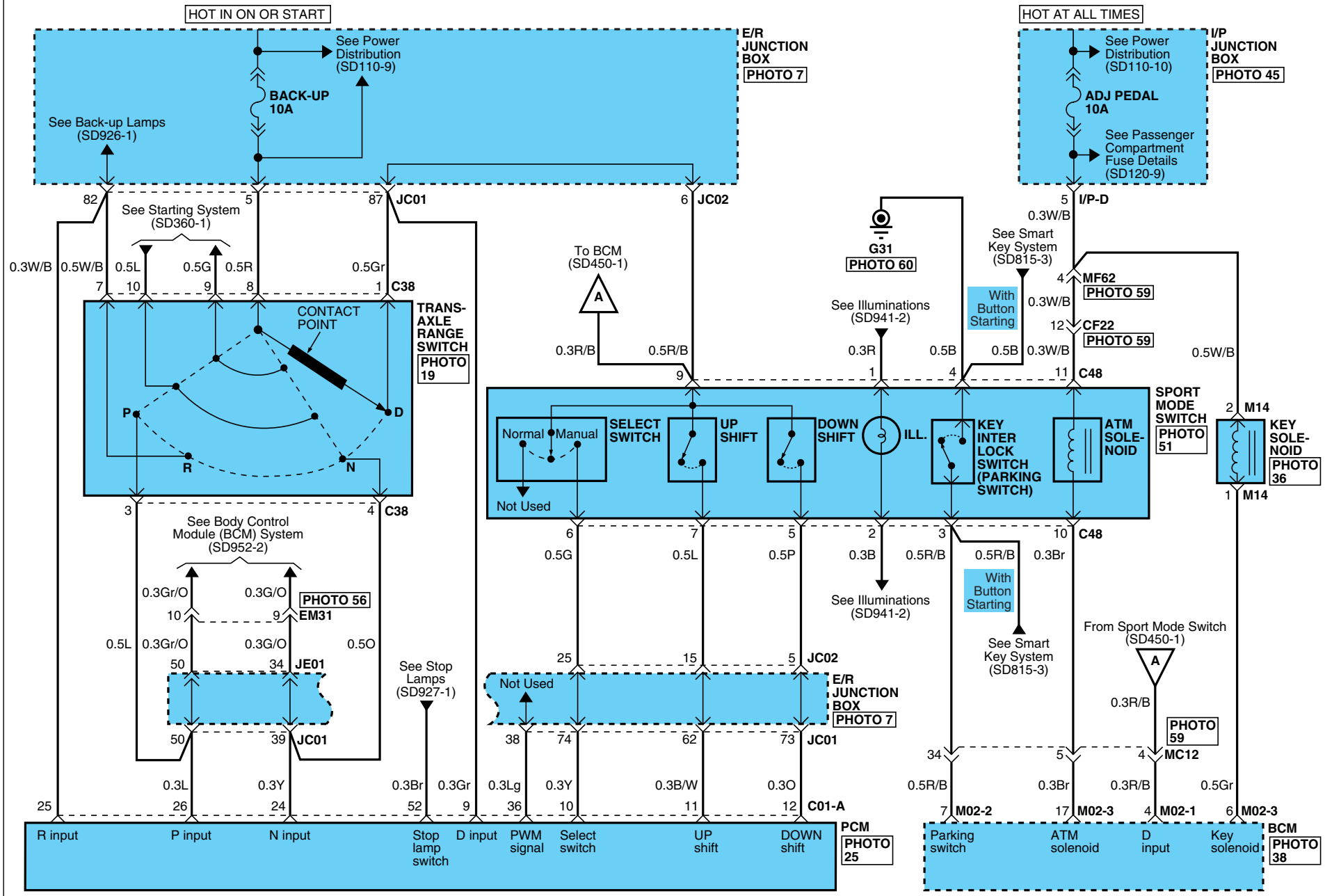

# AUTOMATIC TRANSAXLE CONTROL SYSTEM

## Automatic Transaxle Control System (G4KD/G4KE-GSL 2.0L/2.4L) (2)

SD450-2

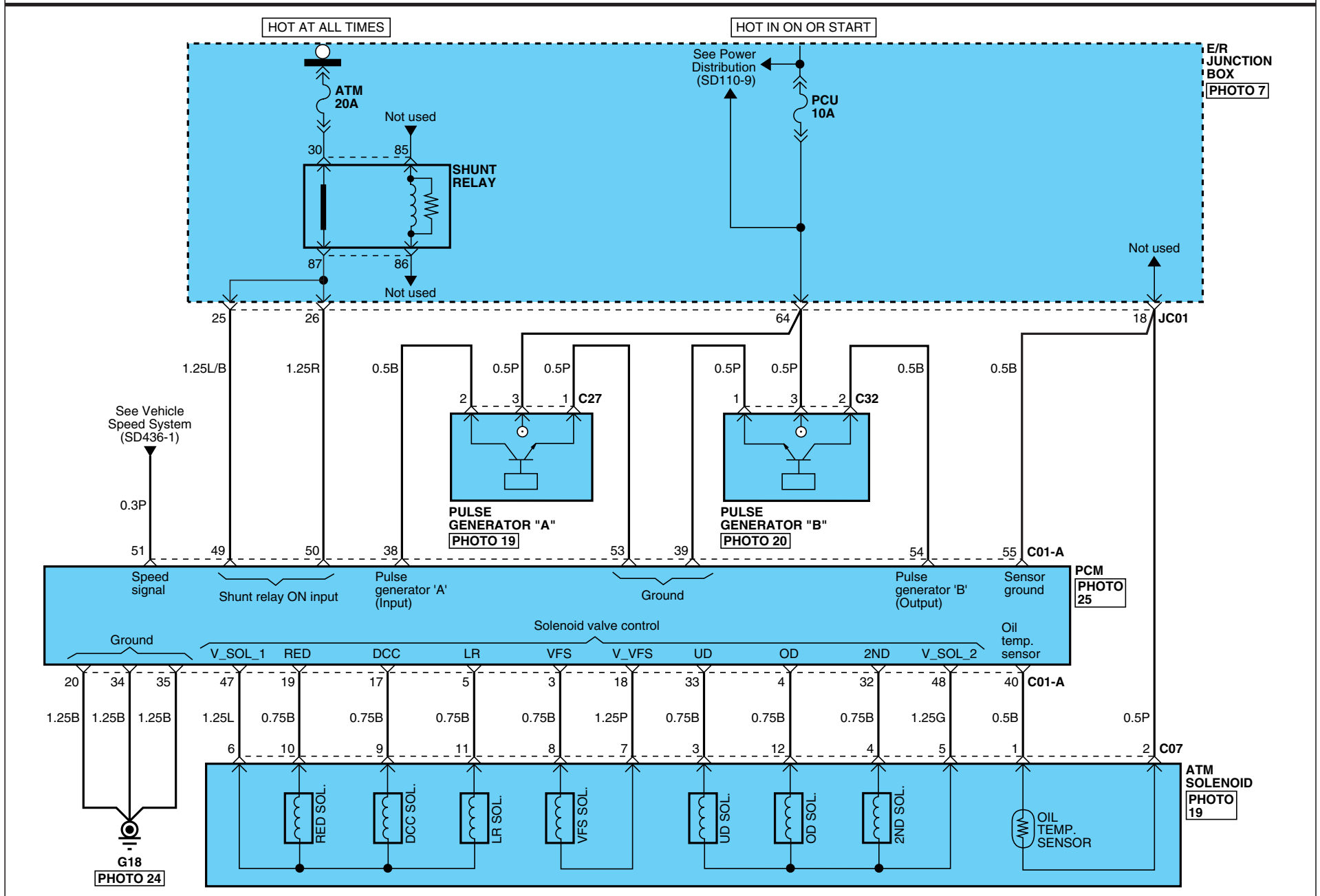

# AUTOMATIC TRANSAXLE CONTROL SYSTEM

## Automatic Transaxle Control System (G4KD/G4KE-GSL 2.0L/2.4L) (3)

SD450-3

**C01-A**

*	*	58	57	*	55	54	53	52	51	50	49	48	47	46
*	44	43	42	*	40	39	38	*	36	35	34	33	32	31
30	29	*	*	26	25	24	*	*	*	20	19	18	17	16
15	14	*	12	11	10	9	*	*	*	5	4	3	2	1

AMP\_TCU\_60F\_B\_SIE

**C07**



KET\_0509WP\_12F\_B

**C27**

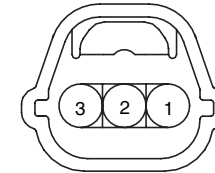

KET\_SSD\_03F\_B\_A

**C32**

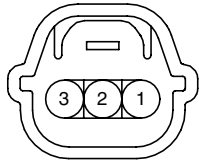

KET\_SSD\_03F\_Gr\_B

**C38**



KET\_SSD\_10F\_B\_A

**C48**

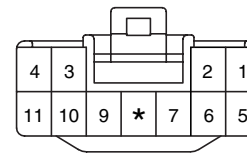

KET\_090II\_11F\_W

**M02-1**

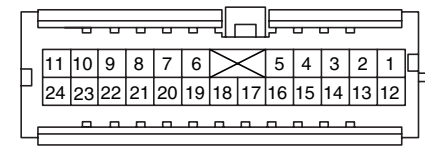

KET\_040III\_24F\_W

**M02-2**

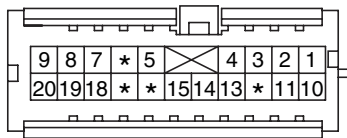

KET\_040III\_20F\_W

**M02-3**

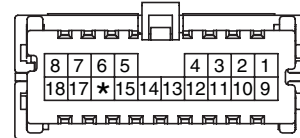

KET\_040III\_18F\_W

**M14**

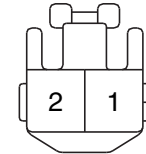

KET\_090II\_02F\_B\_R

**BLANK**



## AUTOMATIC TRANSAXLE CONTROL SYSTEM

Automatic Transaxle Control System (G4KD/G4KE-GSL 2.0L/2.4L) (4)

SD450-4

MEMO



# AUTOMATIC TRANSAXLE CONTROL SYSTEM

## Automatic Transaxle Control System (G6EA-GSL 2.7L) (2)

SD450-6

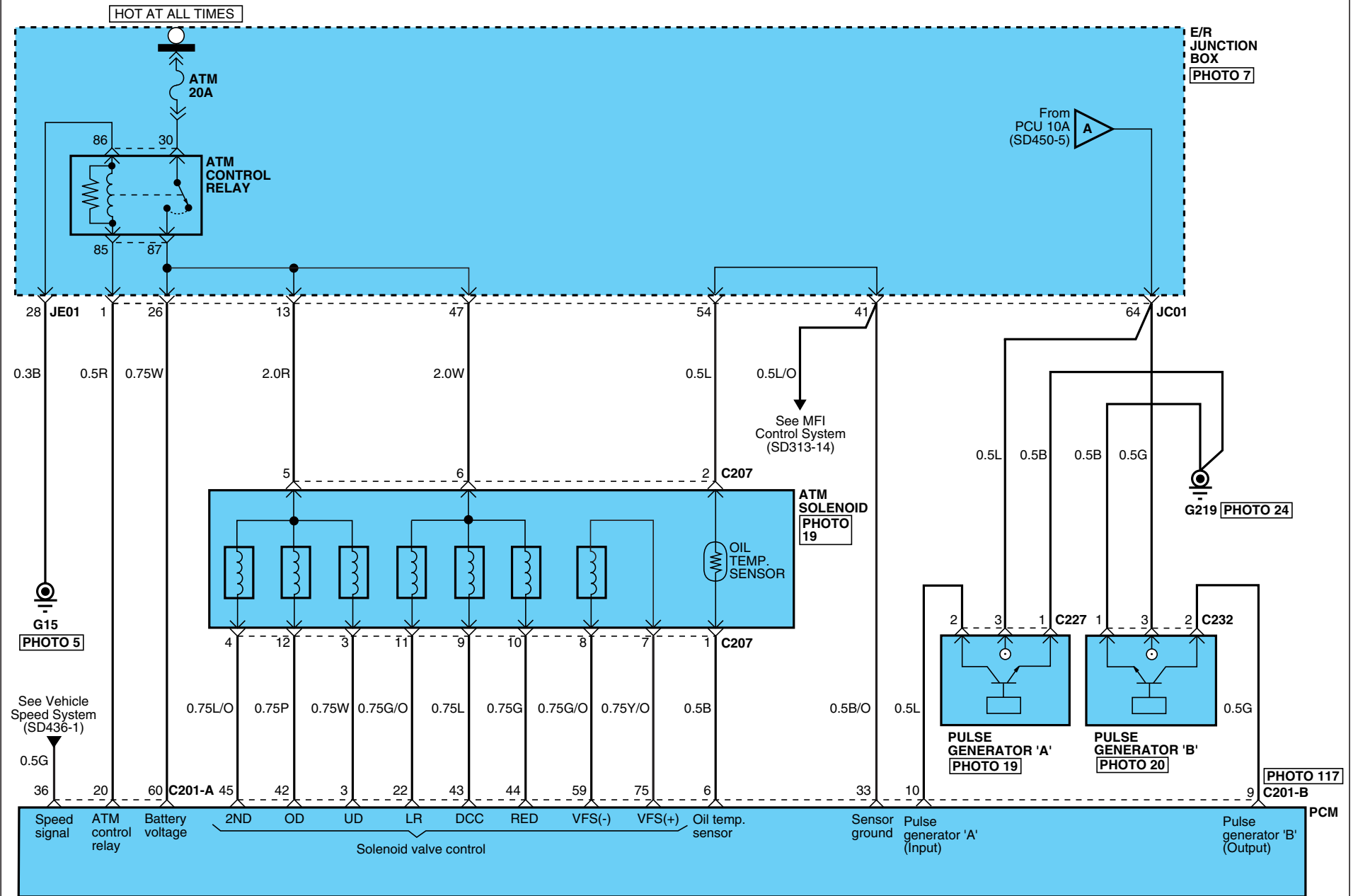

# AUTOMATIC TRANSAXLE CONTROL SYSTEM

## Automatic Transaxle Control System (G6EA-GSL 2.7L) (3)

SD450-7

**C48**

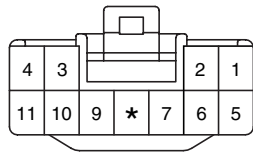

KET\_090II\_11F\_W

**BLANK**

**C201-A**

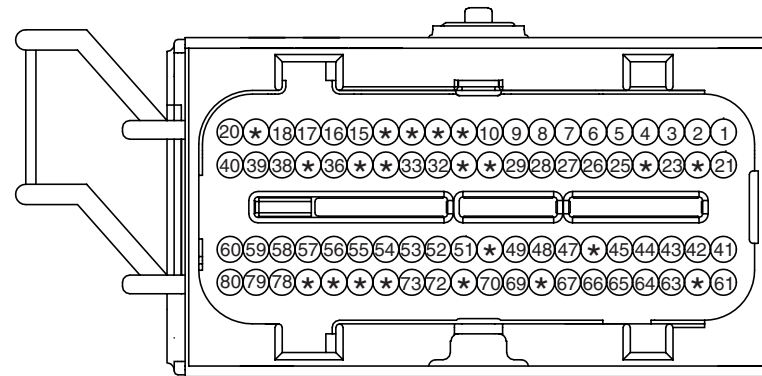

PKD\_ECU\_80F\_GR\_1

**C201-B**

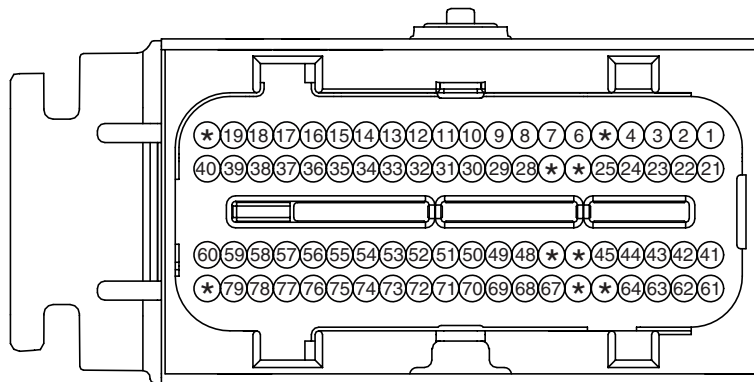

PKD\_ECU\_80F\_B\_2

**C207**



KET\_SSD\_12F\_B

**C227**

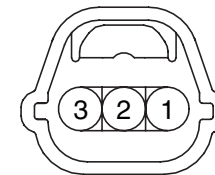

KET\_SSD\_03F\_B\_A

**C232**



KET\_SSD\_03F\_Gr\_B

**C238**



KET\_SSD\_10F\_B\_A

**M02-1**

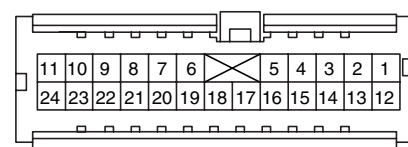

KET\_040III\_24F\_W

**M02-2**

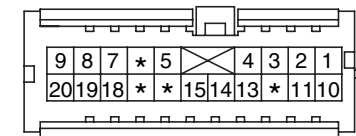

KET\_040III\_20F\_W

**M02-3**

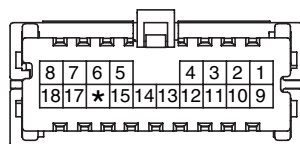

KET\_040III\_18F\_W

**M14**

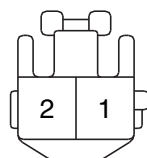

KET\_090II\_02F\_B\_R

**BLANK**

**BLANK**

## AUTOMATIC TRANSAXLE CONTROL SYSTEM

Automatic Transaxle Control System (G6EA-GSL 2.7L) (4)

SD450-8

MEMO

**Automatic Transaxle Control System (D4EA-DSL 2.0L) (1)**

**SD450-9**

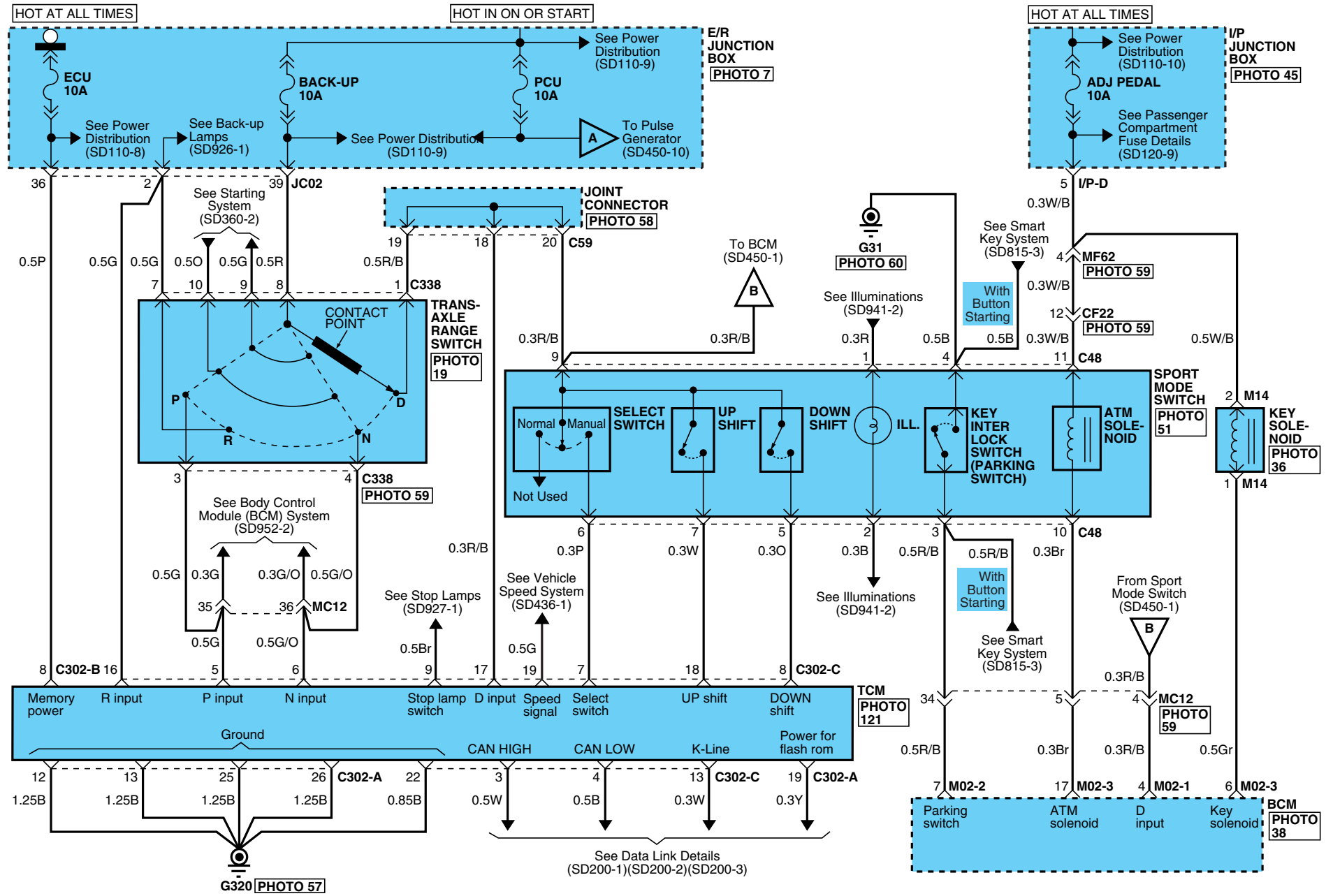

# AUTOMATIC TRANSAXLE CONTROL SYSTEM

## Automatic Transaxle Control System (D4EA-DSL 2.0L) (2)



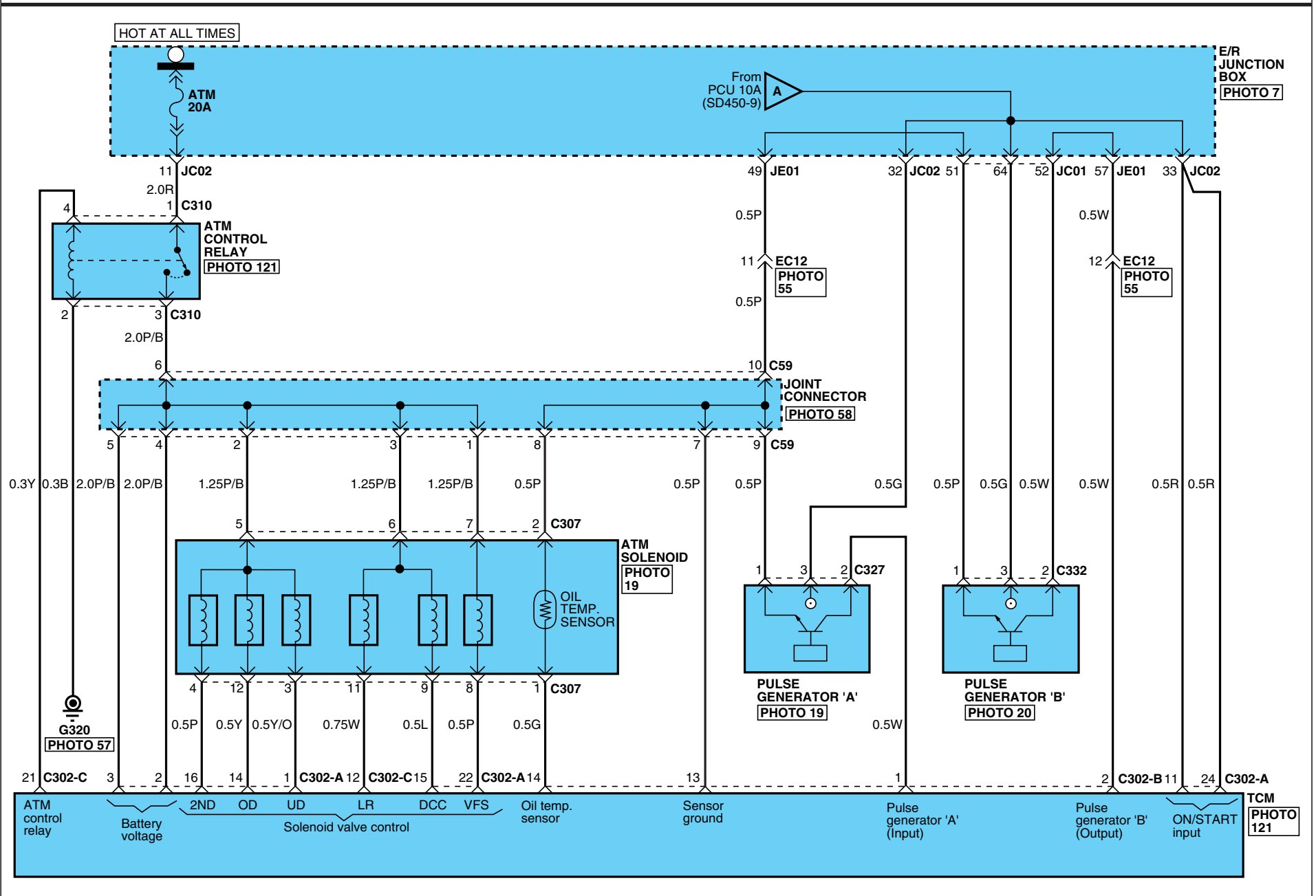

SD450-10

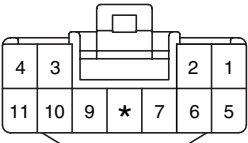
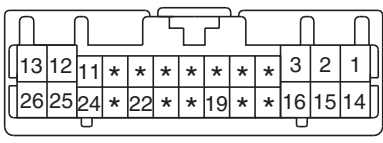
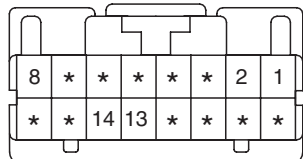
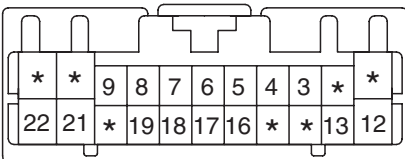

# AUTOMATIC TRANSAXLE CONTROL SYSTEM

## Automatic Transaxle Control System (D4EA-DSL 2.0L) (3)

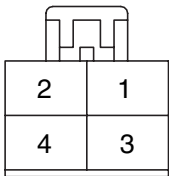
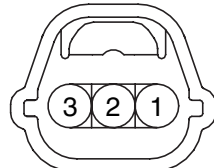
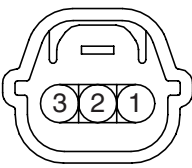
SD450-11

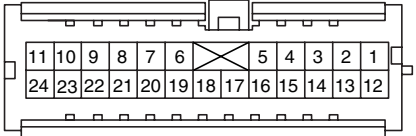
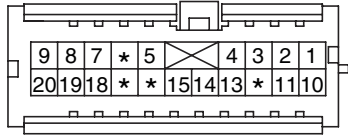
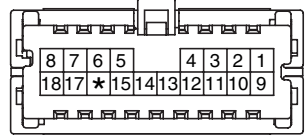
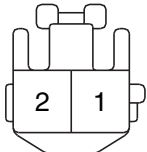
<p style="text-align: center;"><b>C48</b></p>  <p style="text-align: center;">KET_090II_11F_W</p>	<p style="text-align: center;"><b>C302-A</b></p>  <p style="text-align: center;">KET_0407_26F_W</p>	<p style="text-align: center;"><b>C302-B</b></p>  <p style="text-align: center;">KET_0407_16F_W</p>	<p style="text-align: center;"><b>C302-C</b></p>  <p style="text-align: center;">KET_0407_22F_W</p>
<p style="text-align: center;"><b>C307</b></p>  <p style="text-align: center;">KET_SSD_12F_B</p>	<p style="text-align: center;"><b>C310</b></p>  <p style="text-align: center;">KUM_DSD_04F_W</p>	<p style="text-align: center;"><b>C327</b></p>  <p style="text-align: center;">KET_SSD_03F_B_A</p>	<p style="text-align: center;"><b>C332</b></p>  <p style="text-align: center;">KET_SSD_03F_Gr_B</p>
<p style="text-align: center;"><b>C338</b></p>  <p style="text-align: center;">KET_SSD_10F_B_A</p>	<p style="text-align: center;"><b>M02-1</b></p>  <p style="text-align: center;">KET_040III_24F_W</p>	<p style="text-align: center;"><b>M02-2</b></p>  <p style="text-align: center;">KET_040III_20F_W</p>	<p style="text-align: center;"><b>M02-3</b></p>  <p style="text-align: center;">KET_040III_18F_W</p>
<p style="text-align: center;"><b>M14</b></p>  <p style="text-align: center;">KET_090II_02F_B_R</p>	<p style="text-align: center;"><b>BLANK</b></p>	<p style="text-align: center;"><b>BLANK</b></p>	<p style="text-align: center;"><b>BLANK</b></p>



## AUTOMATIC TRANSAXLE CONTROL SYSTEM

Automatic Transaxle Control System (D4EA-DSL 2.0L) (4)

SD450-12

MEMO



# SUPPLEMENTAL RESTRAINT SYSTEM (SRS)

## Supplemental Restraint System (SRS) (2)



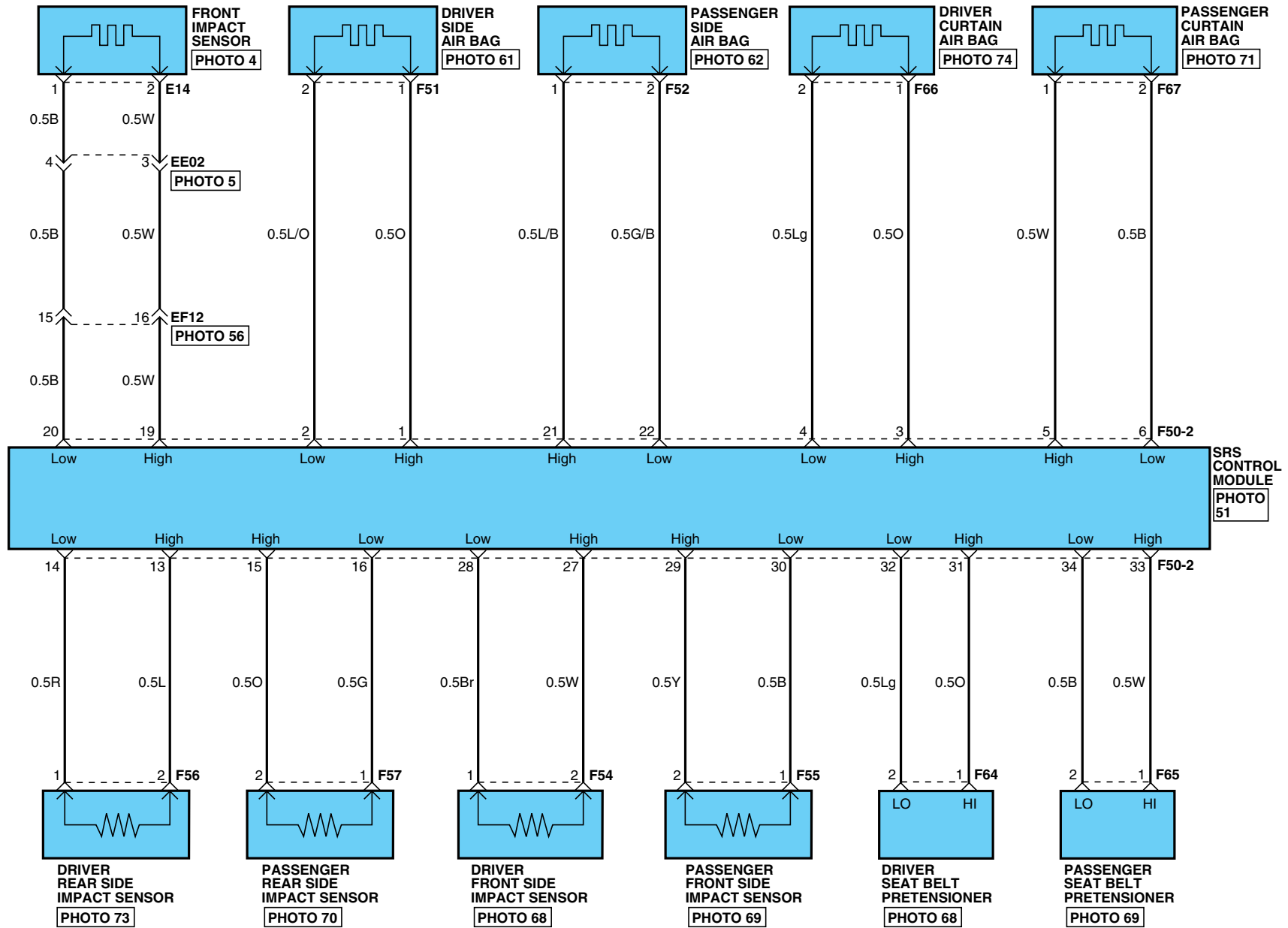





SD569-2

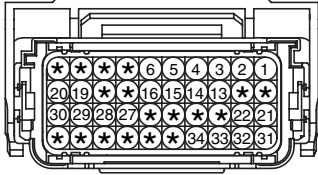

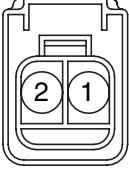
# SUPPLEMENTAL RESTRAINT SYSTEM (SRS)

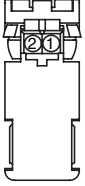
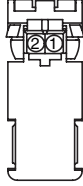
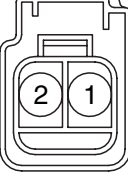
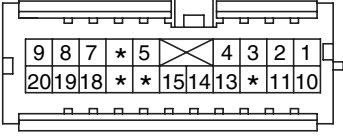
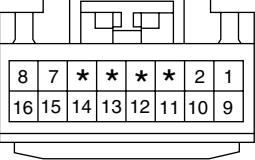
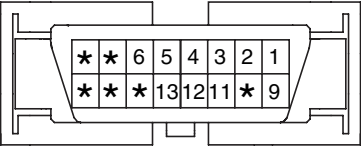
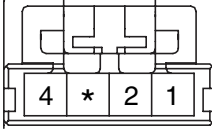
## Supplemental Restraint System (SRS) (3)

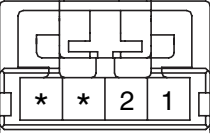
SD569-3

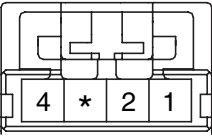
<p><b>F50-2</b></p>  <p>AMP_ACU_40F</p>	<p><b>F51/F52</b></p>  <p>YAZ_040WP_02F_Y</p>	<p><b>F54/F55</b></p>  <p>EPC_E5701_02F_BR</p>	<p><b>F56/F57</b></p>  <p>EPC_E5701_02F_BR</p>
<p><b>F64/F65</b></p>  <p>AMP_SQUIB_02F_Y</p>	<p><b>F66/F67</b></p>  <p>JST_SQS_A</p>	<p><b>E14</b></p>  <p>EPC_E5069_02F_B</p>	<p><b>M02-2</b></p>  <p>KET_040III_20F_W</p>
<p><b>M03-2</b></p>  <p>MLX_040III_16F_Gr</p>	<p><b>M18</b></p>  <p>MLX_OBDII_16F_B_SIN</p>	<p><b>M29</b></p>  <p>AMP_MQS_04F_B</p>	<p><b>M70-1</b></p>  <p>AMP_ACU_24F</p>
<p><b>M71</b></p>  <p>YAZ_040_04F_Y</p>	<p><b>M72</b></p>  <p>YAZ_040WP_02F_Y</p>	<p><b>M74</b></p>  <p>AMP_MQS_04F_Y</p>	<p><b>BLANK</b></p>

**SUPPLEMENTAL RESTRAINT SYSTEM (SRS)**

**Supplemental Restraint System (SRS) (4)**

**SD569-4**

**MEMO**

# ANTI-LOCK BRAKE SYSTEM (ABS)

E8B3DA3C

## Anti-Lock Brake System (ABS) (1)

SD587-1

**MGH-40**

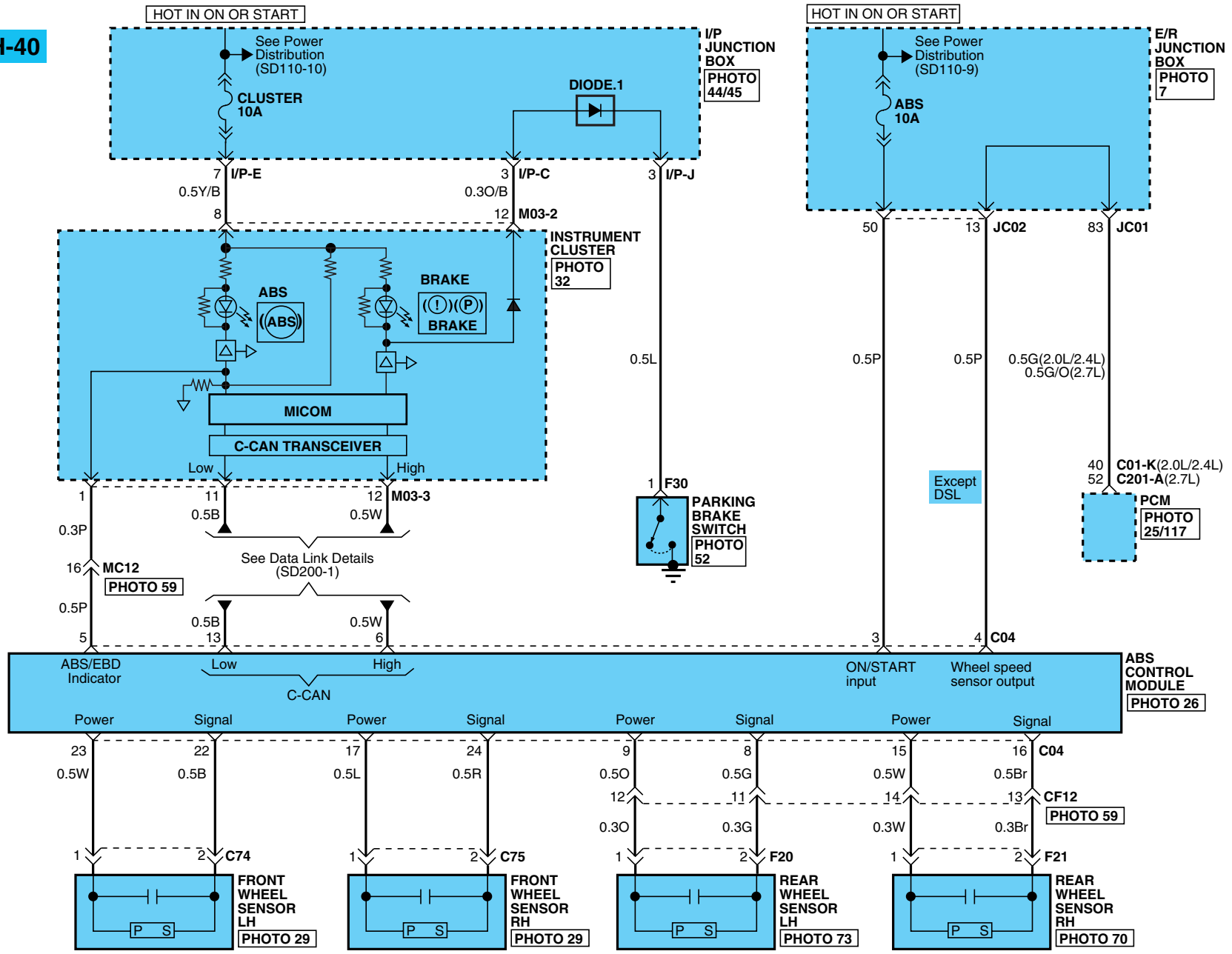

# ANTI-LOCK BRAKE SYSTEM (ABS)

## Anti-Lock Brake System (ABS) (2)

SD587-2

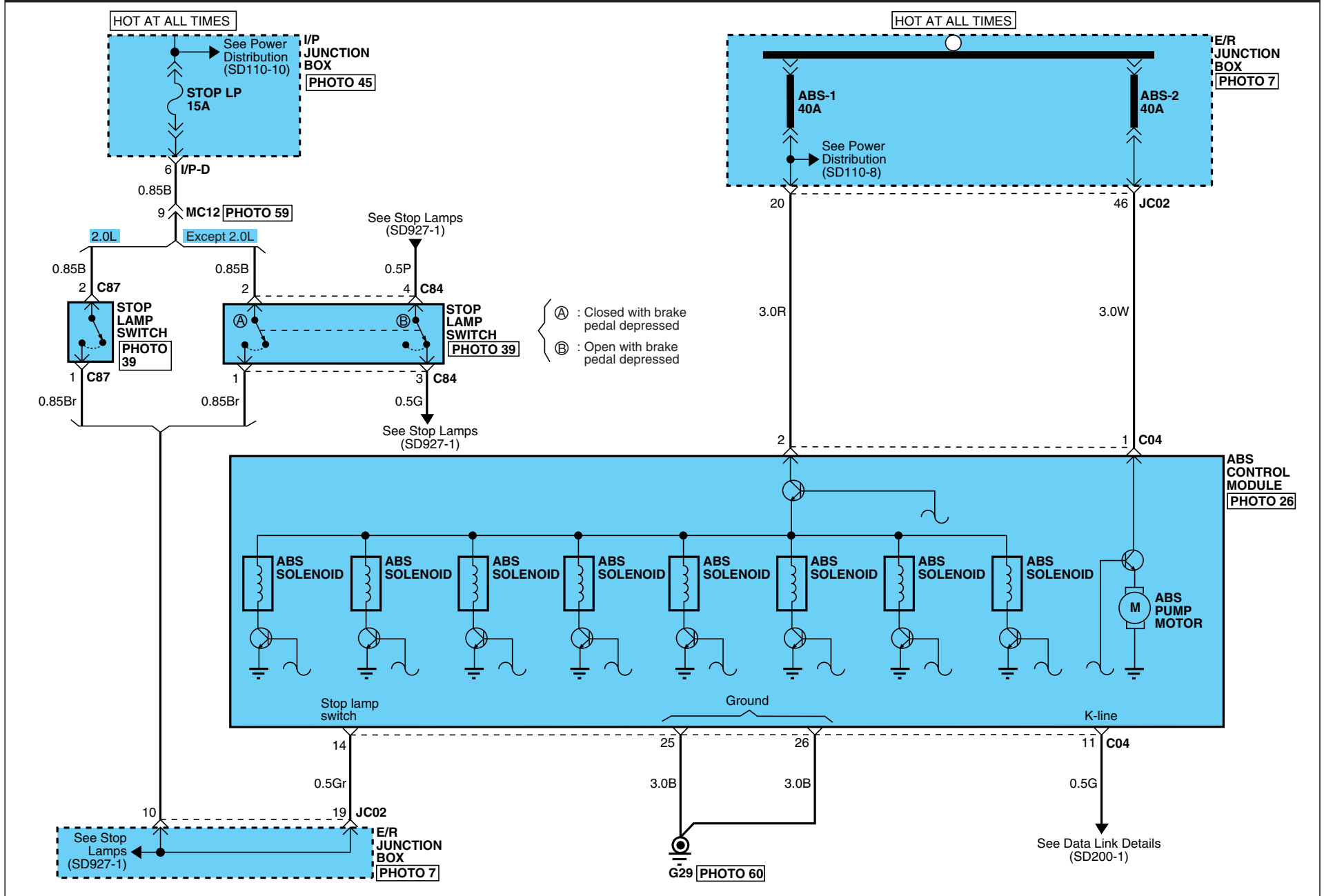

# ANTI-LOCK BRAKE SYSTEM (ABS)

## Anti-Lock Brake System (ABS) (3)

SD587-3

**C01-K**

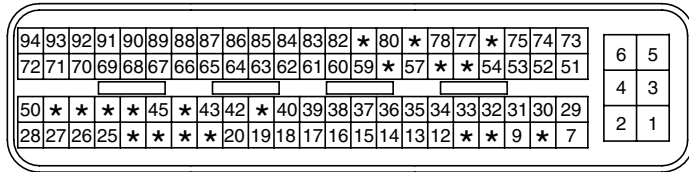

AMP\_PCU\_94F\_B\_SIE

**C04**

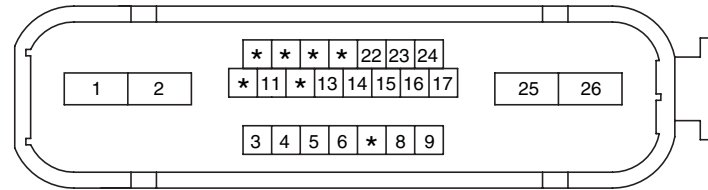

AMP\_ABS\_26F\_B

**C74**

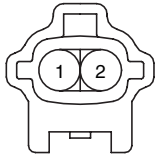

KET\_090IWP\_02M\_B

**C75**

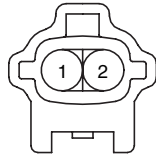

KET\_090IWP\_02M\_B

**C84**

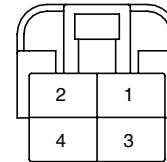

KET\_250DL\_04F\_W

**C87**

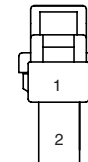

KET\_250DL\_02F\_W

**C201-A**

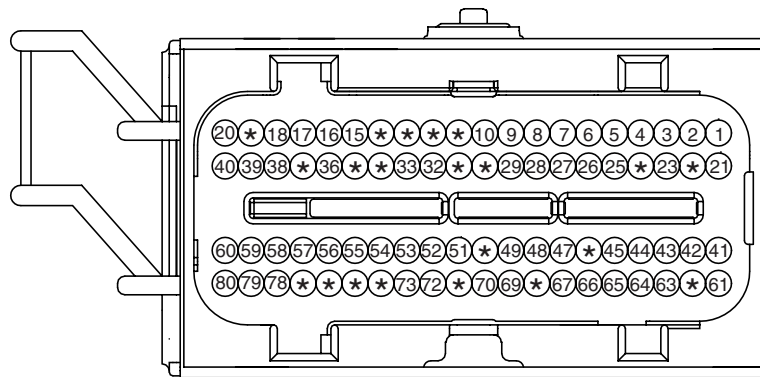

PKD\_ECU\_80F\_GR\_1

**F20/F21**

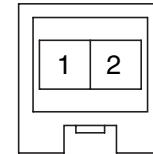

AMP\_090III\_02M\_W

**F30**

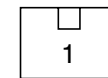

AMP\_PLM1\_01F\_B

**M03-2**

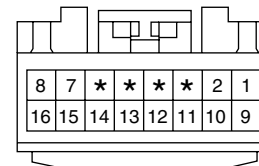

MLX\_040III\_16F\_Gr

**M03-3**

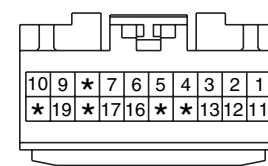

MLX\_040III\_20F\_Gr



## ANTI-LOCK BRAKE SYSTEM (ABS)

Anti-Lock Brake System (ABS) (4)

SD587-4

MEMO

# ELECTRONIC STABILITY PROGRAM (ESP) SYSTEM

EDAA0EBD

## Electronic Stability Program (ESP) System (1)

SD588-1

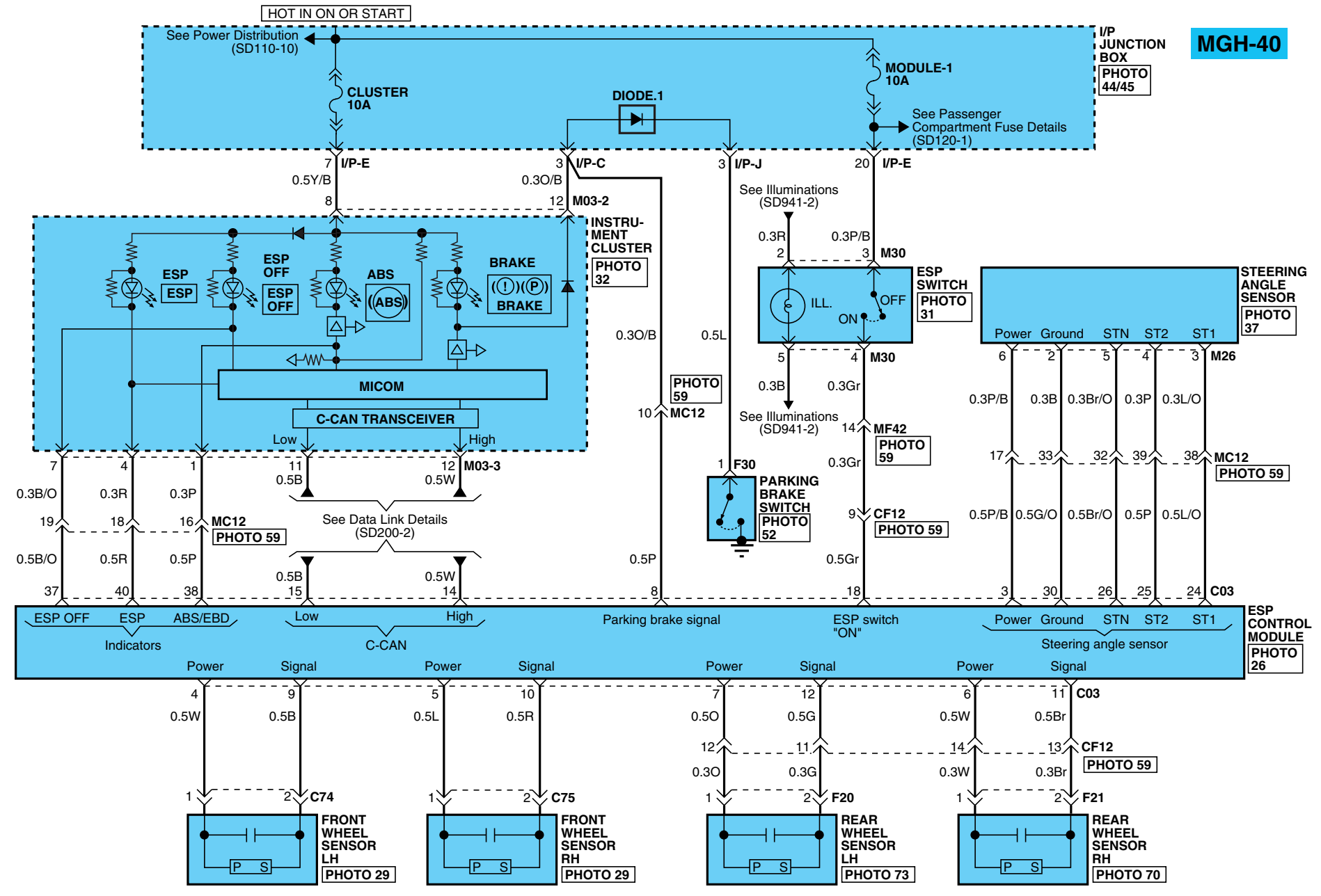

# ELECTRONIC STABILITY PROGRAM (ESP) SYSTEM

## Electronic Stability Program (ESP) System (2)

SD588-2

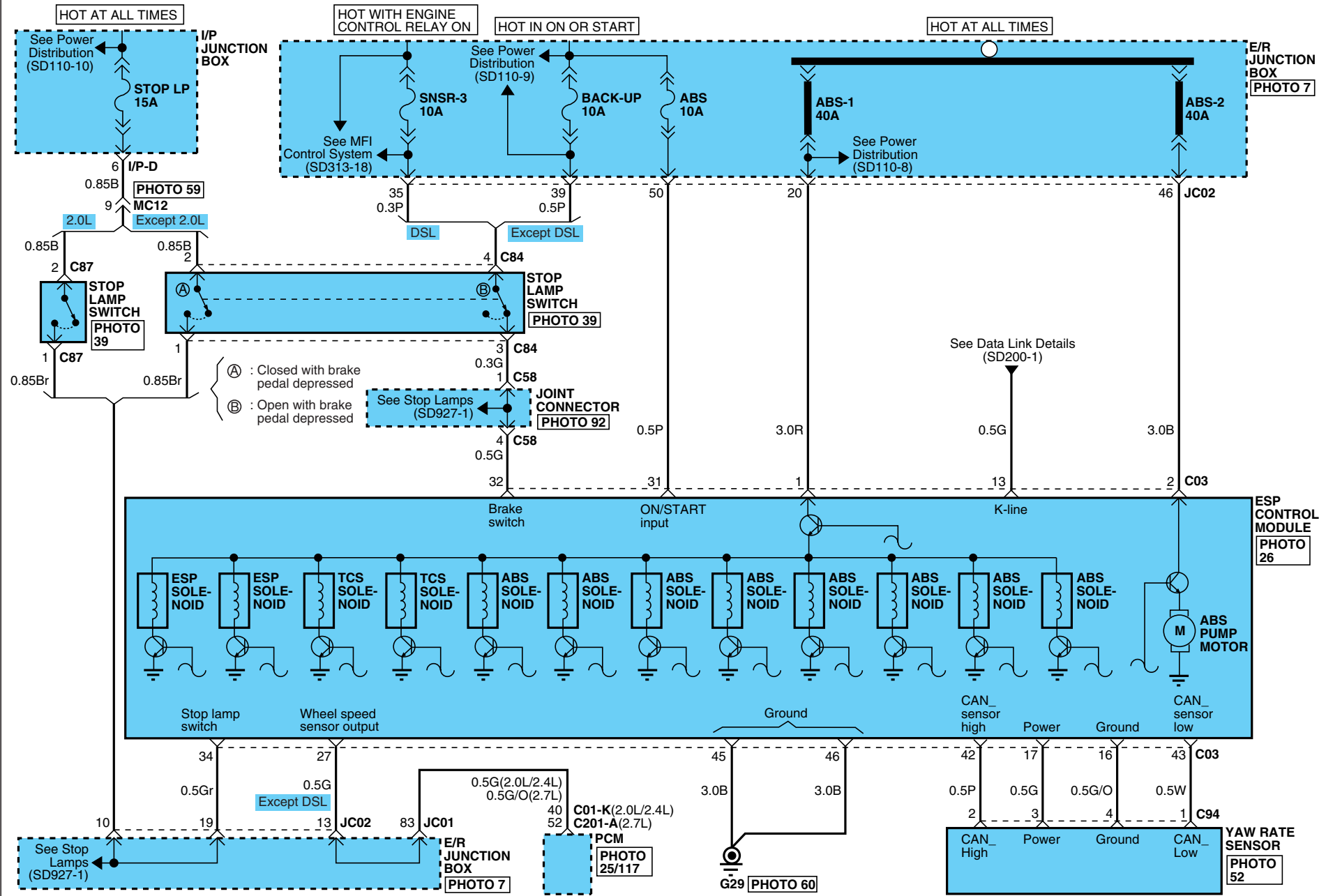

# ELECTRONIC STABILITY PROGRAM (ESP) SYSTEM

## Electronic Stability Program (ESP) System (3)

SD588-3

**C01-K**

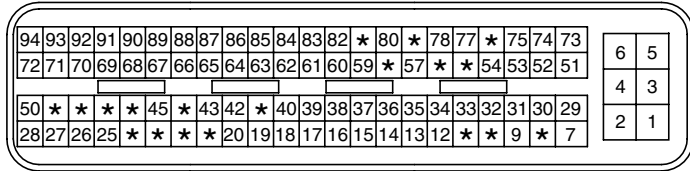

AMP\_PCU\_94F\_B\_SIE

**C03**

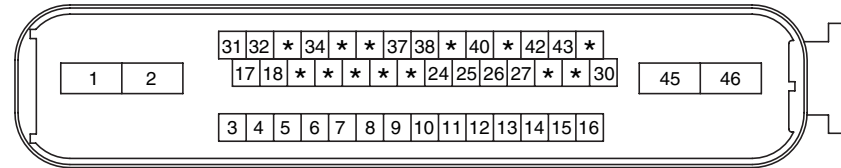

AMP\_ESP\_46F\_B

**C74/C75**

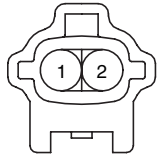

KET\_090IWP\_02M\_B

**C84**

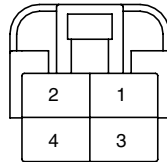

KET\_250DL\_04F\_W

**C87**

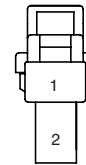

KET\_250DL\_02F\_W

**C94**

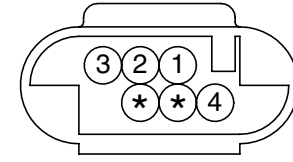

AMP\_MQSWP\_06F\_GR\_1

**C201-A**

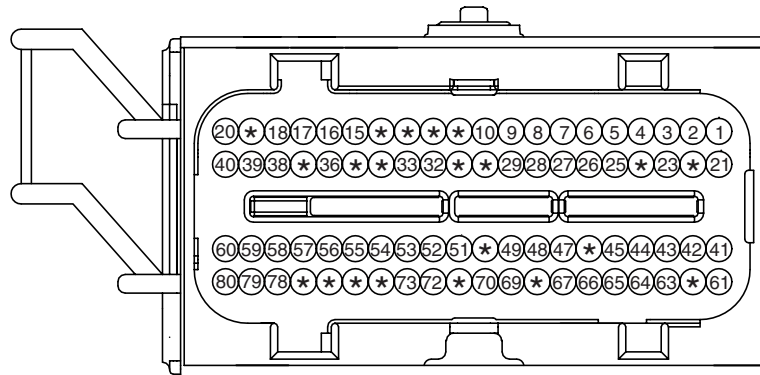

PKD\_ECU\_80F\_GR\_1

**F20**

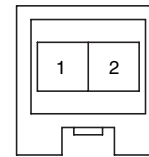

AMP\_090III\_02M\_W

**F21**

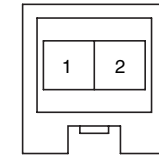

AMP\_090III\_02M\_W

**F30**

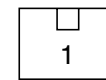

AMP\_PLM1\_01F\_B

**M03-2**

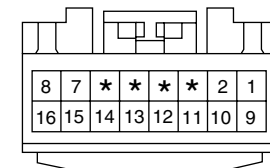

MLX\_040III\_16F\_Gr

**M03-3**

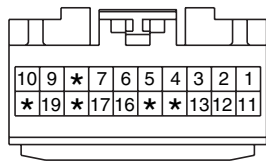

MLX\_040III\_20F\_Gr

**M26**

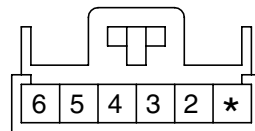

AMP\_070\_06F\_W\_1F

**M30**

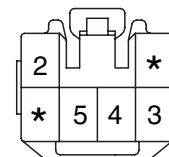

KET\_090II\_06F\_G

**BLANK**

**ELECTRONIC STABILITY PROGRAM (ESP) SYSTEM**

**Electronic Stability Program (ESP) System (4)**

**SD588-4**

**MEMO**

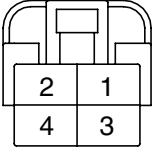
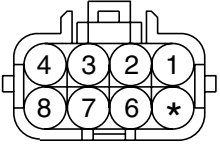
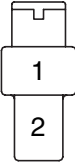
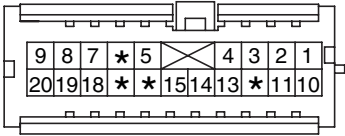
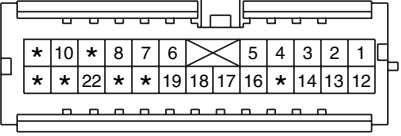
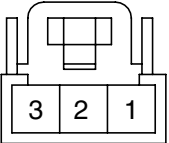

# FUEL FILLER DOOR & TRUNK LID OPENER

Fuel Filler Door & Trunk Lid Opener (2)			SD812-2
<p style="text-align: center;"><b>D16</b></p>  <p style="text-align: center;">KET_250DL_04F_W</p>	<p style="text-align: center;"><b>D17</b></p>  <p style="text-align: center;">KET_SWP_08F_B</p>	<p style="text-align: center;"><b>F03</b></p>  <p style="text-align: center;">KET_250_02F_W</p>	<p style="text-align: center;"><b>M02-2</b></p>  <p style="text-align: center;">KET_040III_20F_W</p>
<p style="text-align: center;"><b>M02-4</b></p>  <p style="text-align: center;">KET_040III_24F_Gr</p>	<p style="text-align: center;"><b>R12</b></p>  <p style="text-align: center;">AMP_070_03F_W</p>	<p><b>BLANK</b></p>	<p><b>BLANK</b></p>

Power Door Locks (1)

SD813-1

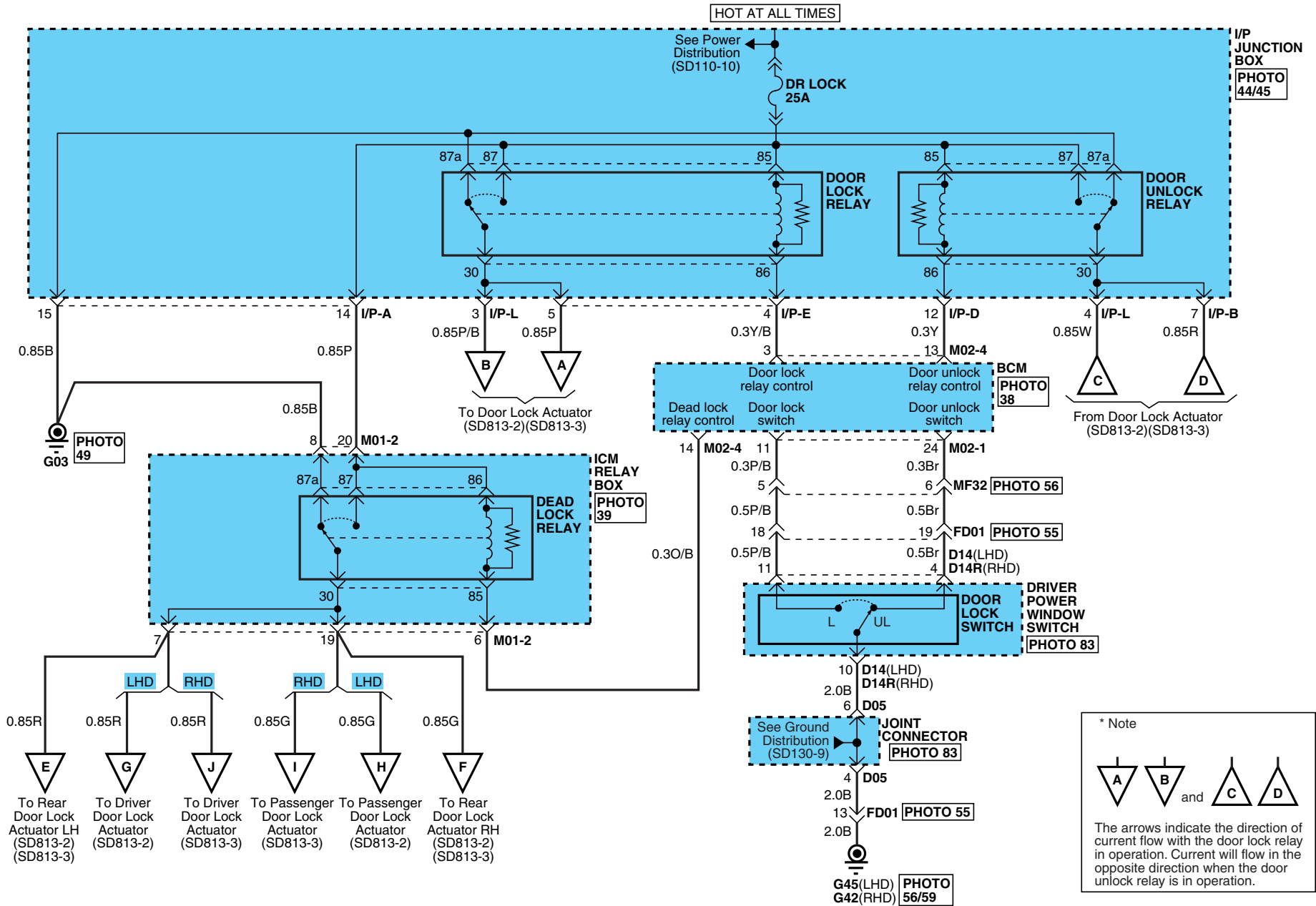

\* Note

The arrows indicate the direction of current flow with the door lock relay in operation. Current will flow in the opposite direction when the door unlock relay is in operation.



# POWER DOOR LOCKS

## Power Door Locks (2)

SD813-2

**LHD**

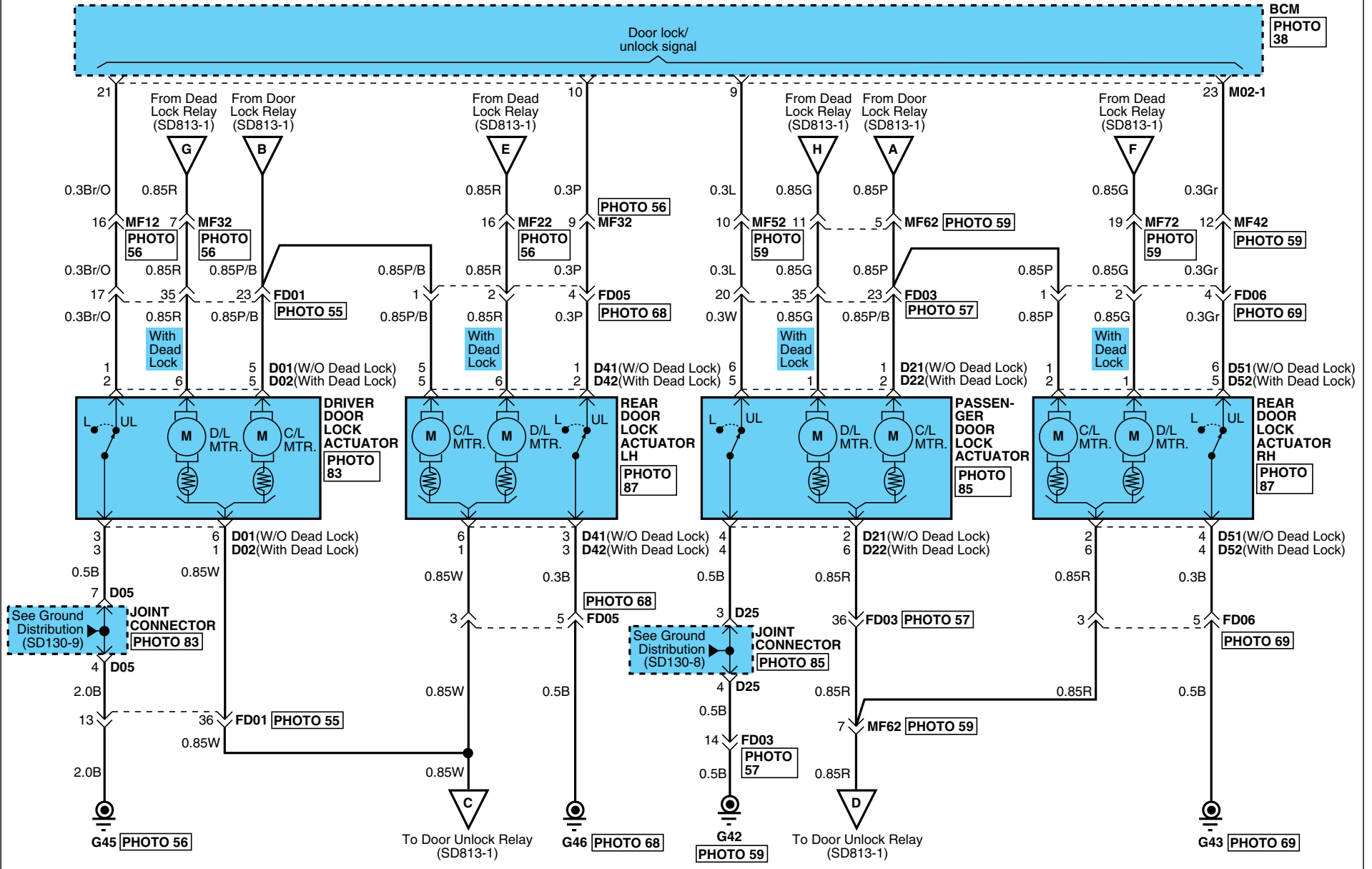

# POWER DOOR LOCKS

## Power Door Locks (3)

SD813-3

**RHD**

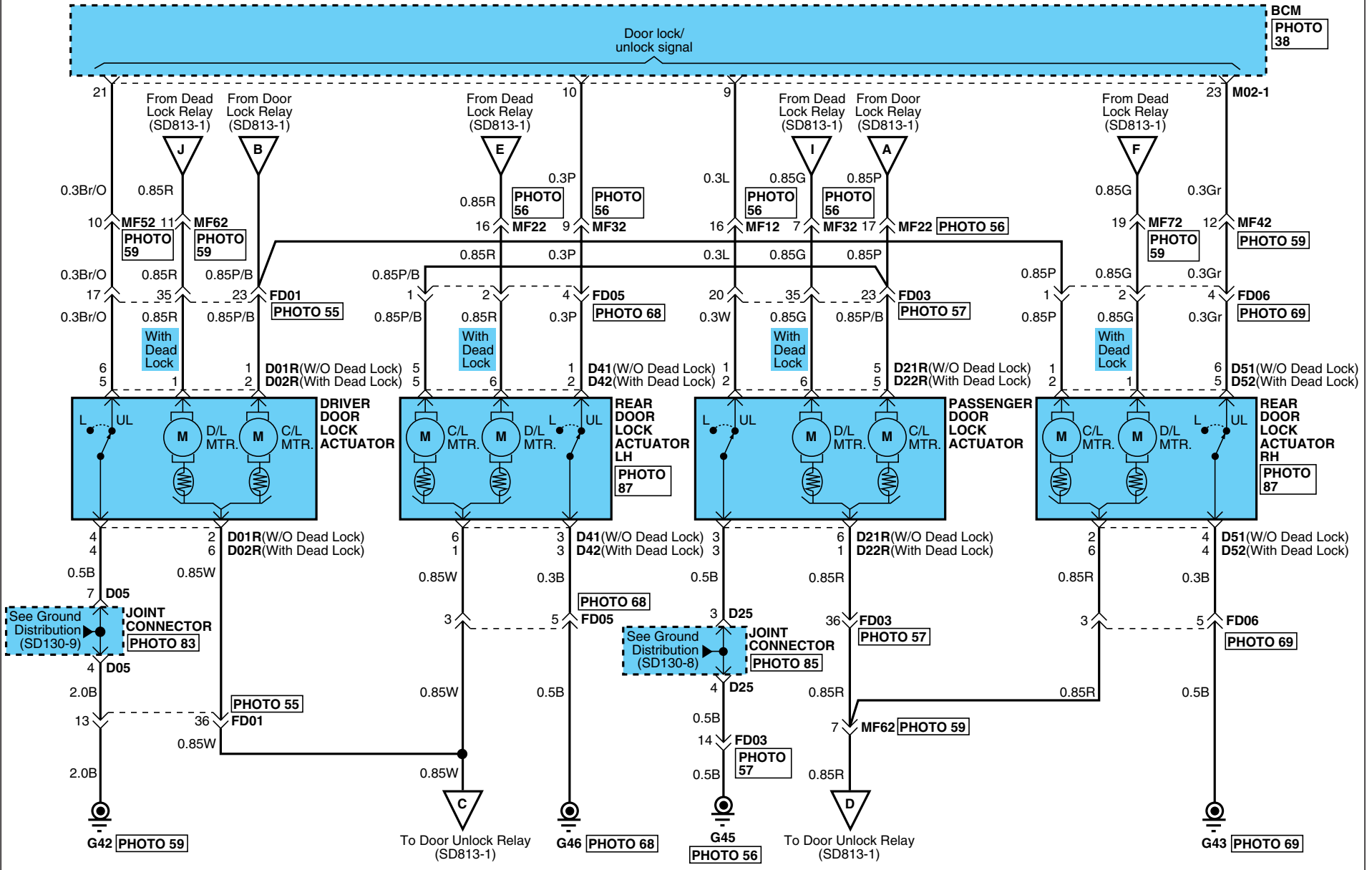

# POWER DOOR LOCKS

## Power Door Locks (4)

SD813-4

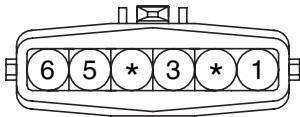
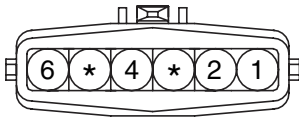
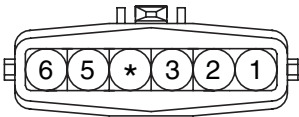
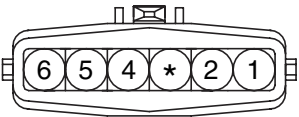
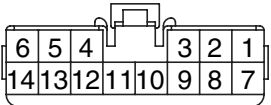
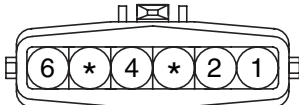
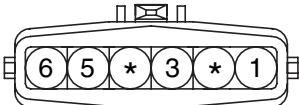
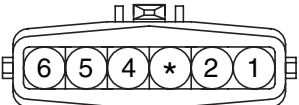
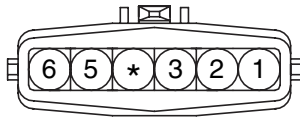
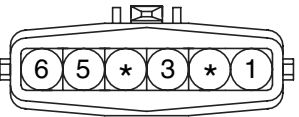
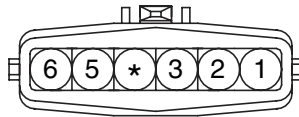
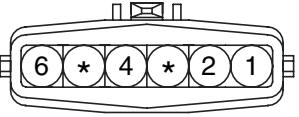
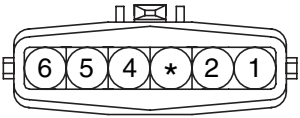
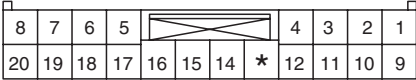
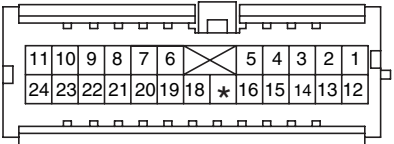
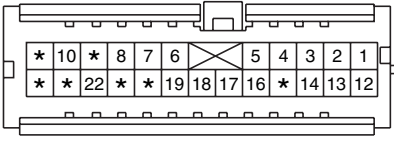
<p><b>D01</b></p>  <p>KET_SNSR_06F_B_YAZ</p>	<p><b>D01R</b></p>  <p>KET_SNSR_06F_B_YAZ</p>	<p><b>D02</b></p>  <p>KET_SNSR_06F_B_YAZ</p>	<p><b>D02R</b></p>  <p>KET_SNSR_06F_B_YAZ</p>
<p><b>D14/D14R</b></p>  <p>KET_090II_14F_B</p>	<p><b>D21</b></p>  <p>KET_SNSR_06F_B_YAZ</p>	<p><b>D21R</b></p>  <p>KET_SNSR_06F_B_YAZ</p>	<p><b>D22</b></p>  <p>KET_SNSR_06F_B_YAZ</p>
<p><b>D22R</b></p>  <p>KET_SNSR_06F_B_YAZ</p>	<p><b>D41</b></p>  <p>KET_SNSR_06F_B_YAZ</p>	<p><b>D42</b></p>  <p>KET_SNSR_06F_B_YAZ</p>	<p><b>D51</b></p>  <p>KET_SNSR_06F_B_YAZ</p>
<p><b>D52</b></p>  <p>KET_SNSR_06F_B_YAZ</p>	<p><b>M01-2</b></p>  <p>AMP_0925_20F_W</p>	<p><b>M02-1</b></p>  <p>KET_040III_24F_W</p>	<p><b>M02-4</b></p>  <p>KET_040III_24F_Gr</p>

Keyless Entry & Burglar Alarm System (1)

SD814-1

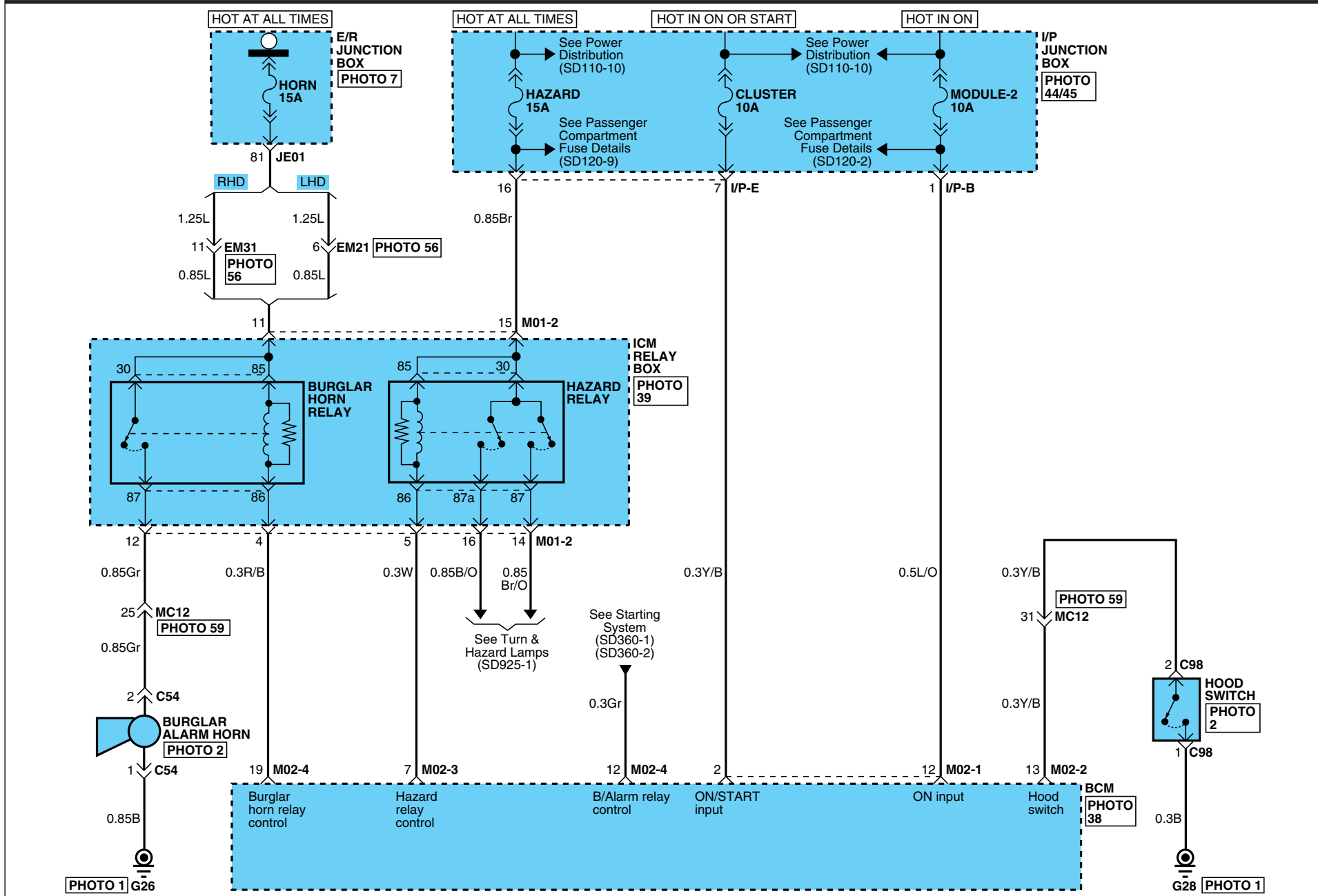

# KEYLESS ENTRY & BURGLAR ALARM SYSTEM

## Keyless Entry & Burglar Alarm System (2)

SD814-2

LHD

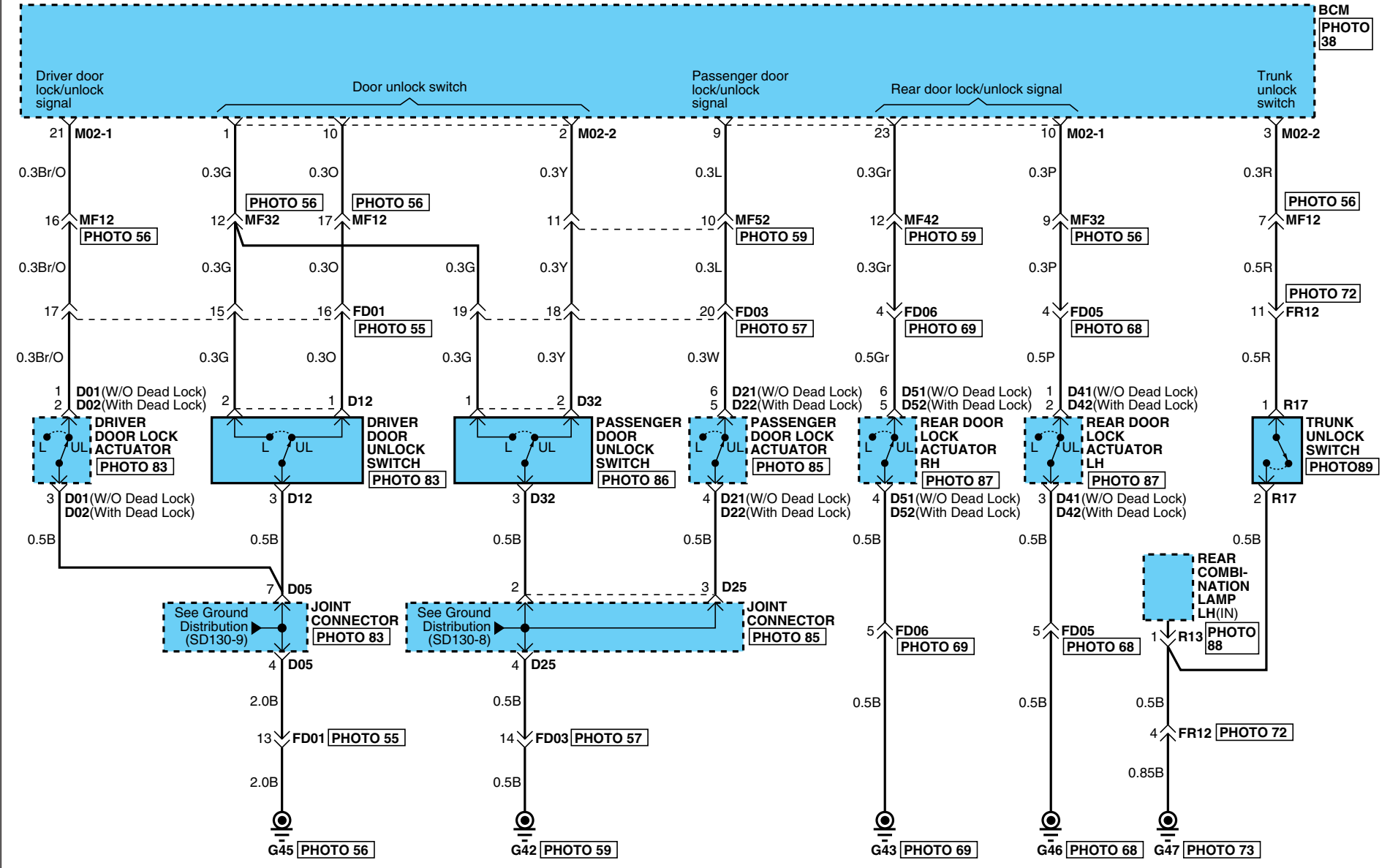

# KEYLESS ENTRY & BURGLAR ALARM SYSTEM

## Keyless Entry & Burglar Alarm System (3)

SD814-3

**RHD**

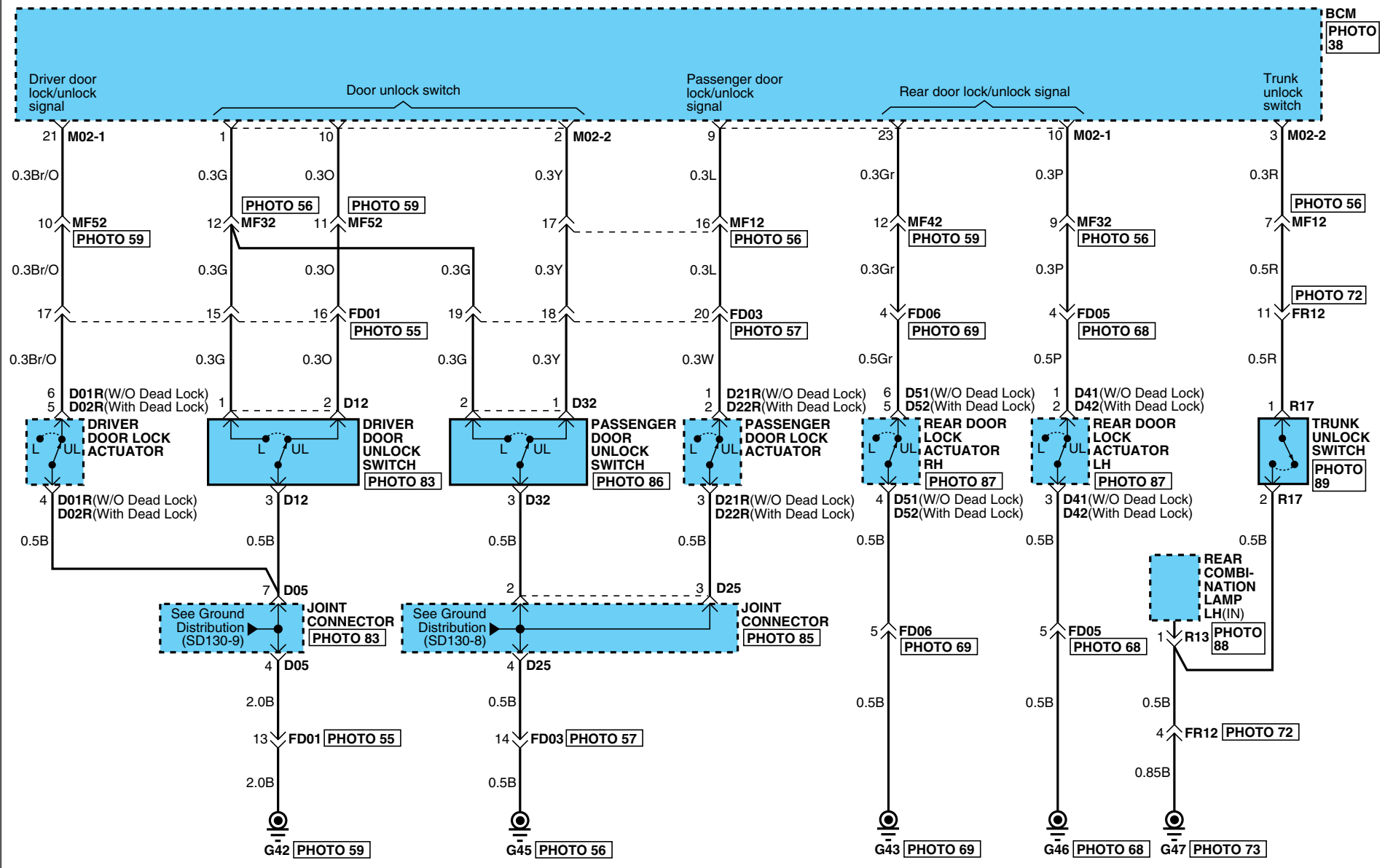

# KEYLESS ENTRY & BURGLAR ALARM SYSTEM

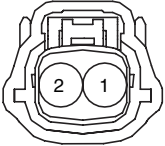
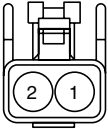
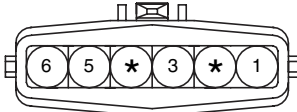
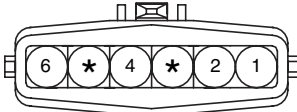
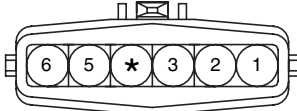
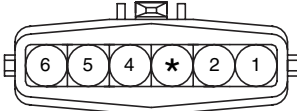
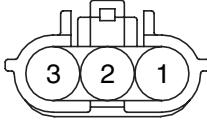
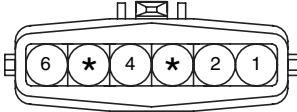
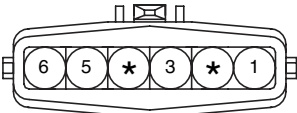
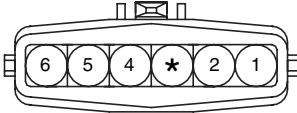
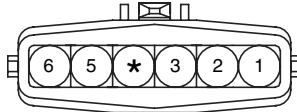
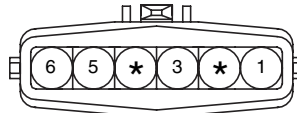
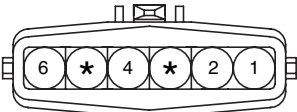
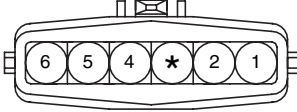
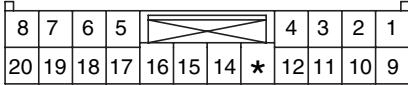
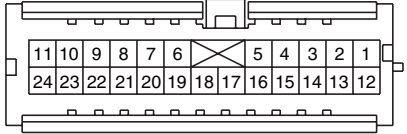
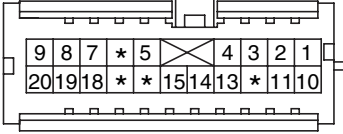
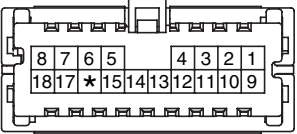
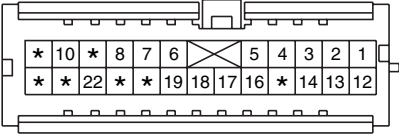
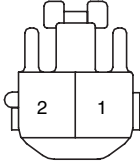
Keyless Entry & Burglar Alarm System (4)			SD814-4
<p><b>C54</b></p>  <p>MLX_HORN_02F_B_FILT</p>	<p><b>C98</b></p>  <p>KET_0901WP_02F_B</p>	<p><b>D01</b></p>  <p>KET_SNSR_06F_B_YAZ</p>	<p><b>D01R</b></p>  <p>KET_SNSR_06F_B_YAZ</p>
<p><b>D02</b></p>  <p>KET_SNSR_06F_B_YAZ</p>	<p><b>D02R</b></p>  <p>KET_SNSR_06F_B_YAZ</p>	<p><b>D12/D32</b></p>  <p>KET_SWP_03F_B</p>	<p><b>D21</b></p>  <p>KET_SNSR_06F_B_YAZ</p>
<p><b>D21R</b></p>  <p>KET_SNSR_06F_B_YAZ</p>	<p><b>D22</b></p>  <p>KET_SNSR_06F_B_YAZ</p>	<p><b>D22R/D42</b></p>  <p>KET_SNSR_06F_B_YAZ</p>	<p><b>D41</b></p>  <p>KET_SNSR_06F_B_YAZ</p>
<p><b>D51</b></p>  <p>KET_SNSR_06F_B_YAZ</p>	<p><b>D52</b></p>  <p>KET_SNSR_06F_B_YAZ</p>	<p><b>M01-2</b></p>  <p>AMP_0925_20F_W</p>	<p><b>M02-1</b></p>  <p>KET_040III_24F_W</p>
<p><b>M02-2</b></p>  <p>KET_040III_20F_W</p>	<p><b>M02-3</b></p>  <p>KET_040III_18F_W</p>	<p><b>M02-4</b></p>  <p>KET_040III_24F_Gr</p>	<p><b>R17</b></p>  <p>KET_090II_02F_Gr_T</p>

Smart Key System (1)

SD815-1

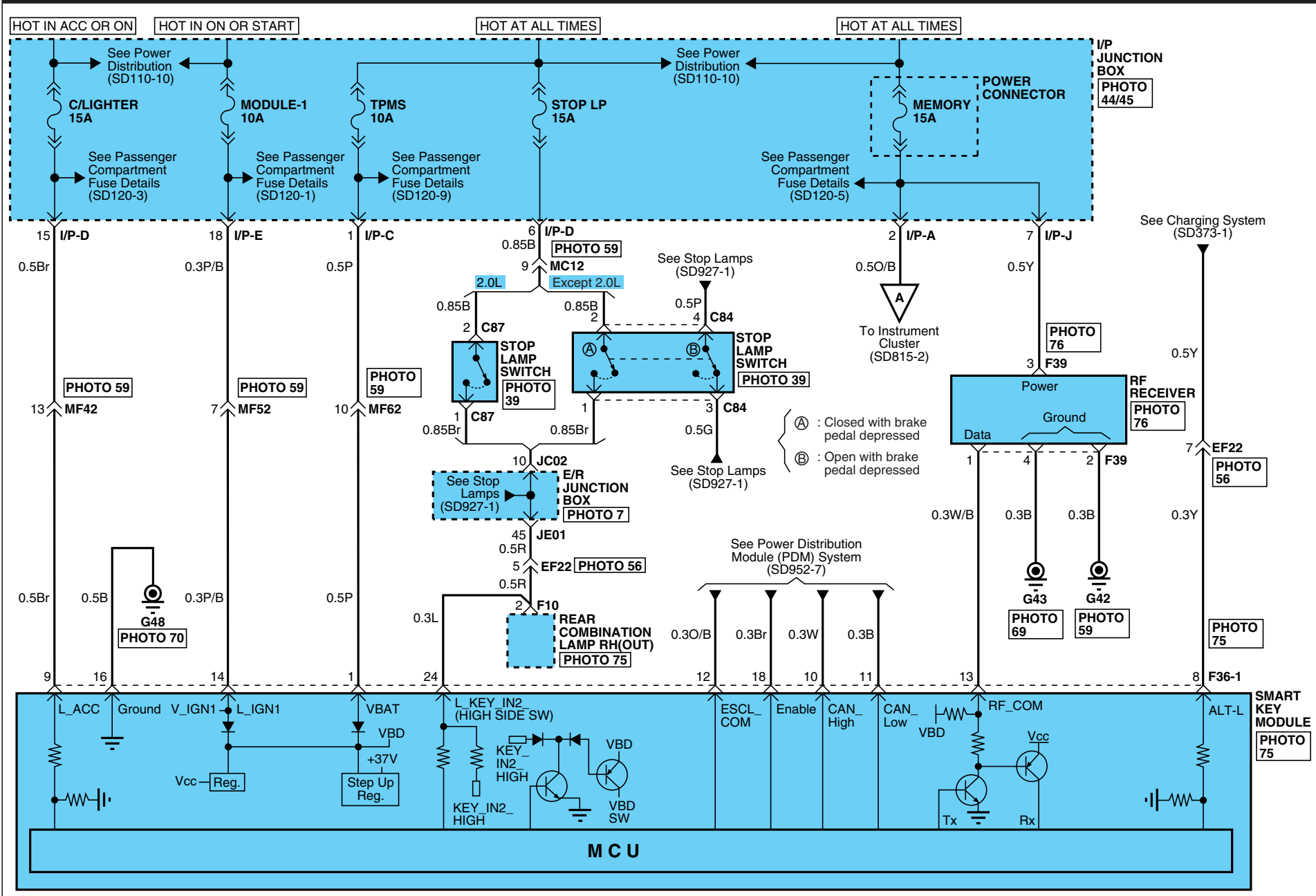



# SMART KEY SYSTEM

## Smart Key System (2)

SD815-2

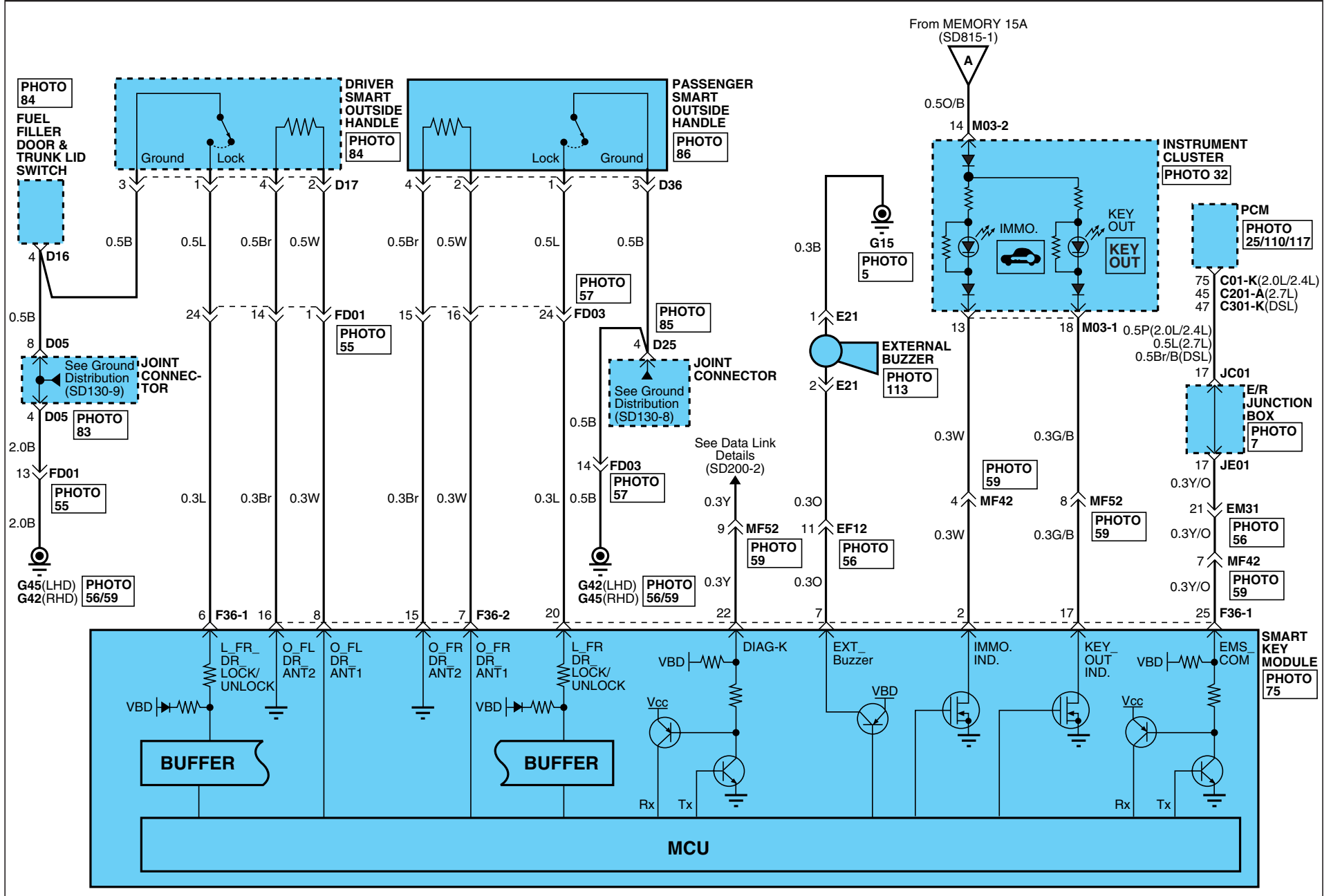



# SMART KEY SYSTEM

## Smart Key System (4)

SD815-4

**C01-K**

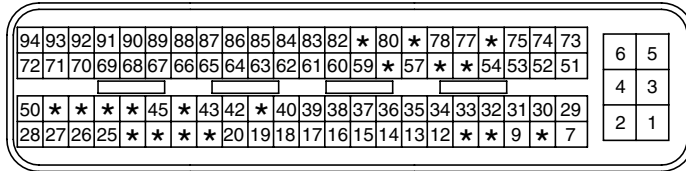

AMP\_PCU\_94F\_B\_SIE

**C301-K**

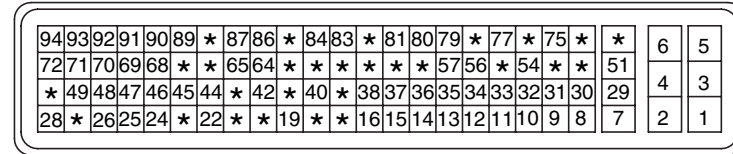

AMP\_PCU\_94F\_B\_SIE

**C201-A**

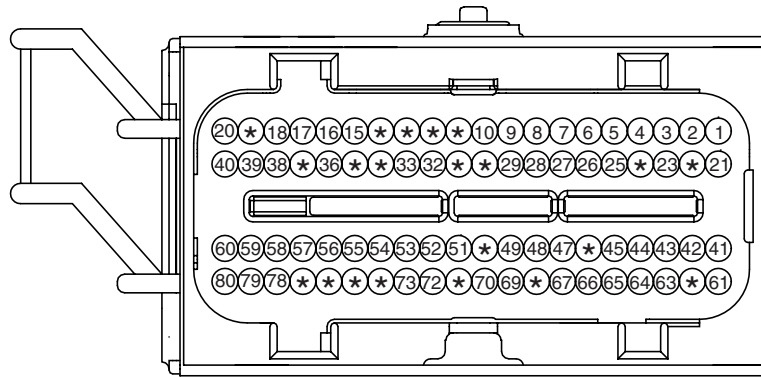

PKD\_ECU\_80F\_GR\_1

**C48**

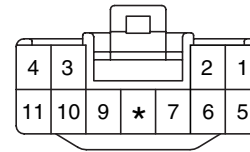

KET\_090II\_11F\_W

**D16**

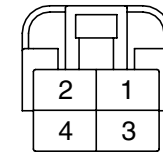

KET\_250DL\_04F\_W

**D17**

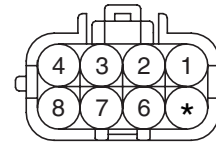

KET\_SWP\_08F\_B

**D36**

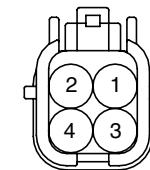

KET\_SWP\_04F\_W

**E21**



KET\_090IWP\_02F\_B

**F36-1**

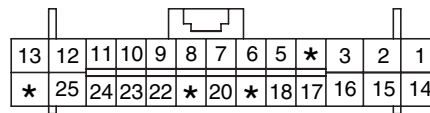

AMP\_0407\_26F\_W\_HD

**F36-2**

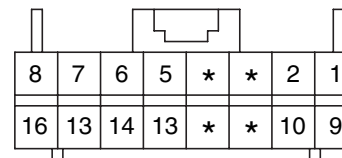

AMP\_0407\_16F\_W\_040

**F37**

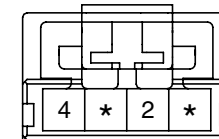

AMP\_MQS\_04F\_B

**F38**

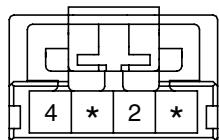

AMP\_MQS\_04F\_B

**F39**

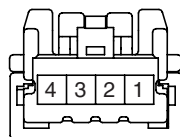

KET\_040III\_04F\_W

**M03-1**

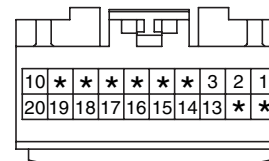

MLX\_040III\_20F\_Gr

**M03-2**

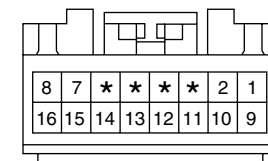

MLX\_040III\_16F\_Gr

# SMART KEY SYSTEM

Smart Key System (5)

SD815-5

M63

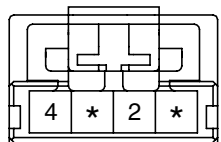

AMP\_MQS\_04F\_B

R23

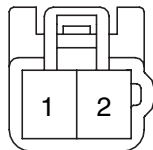

KET\_090II\_02M\_W\_R

R26

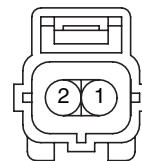

AMP\_EJWP\_02F\_B

BLANK

**SMART KEY SYSTEM**

**Smart Key System (6)**

**SD815-6**

**MEMO**

Sunroof (1)

SD816-1

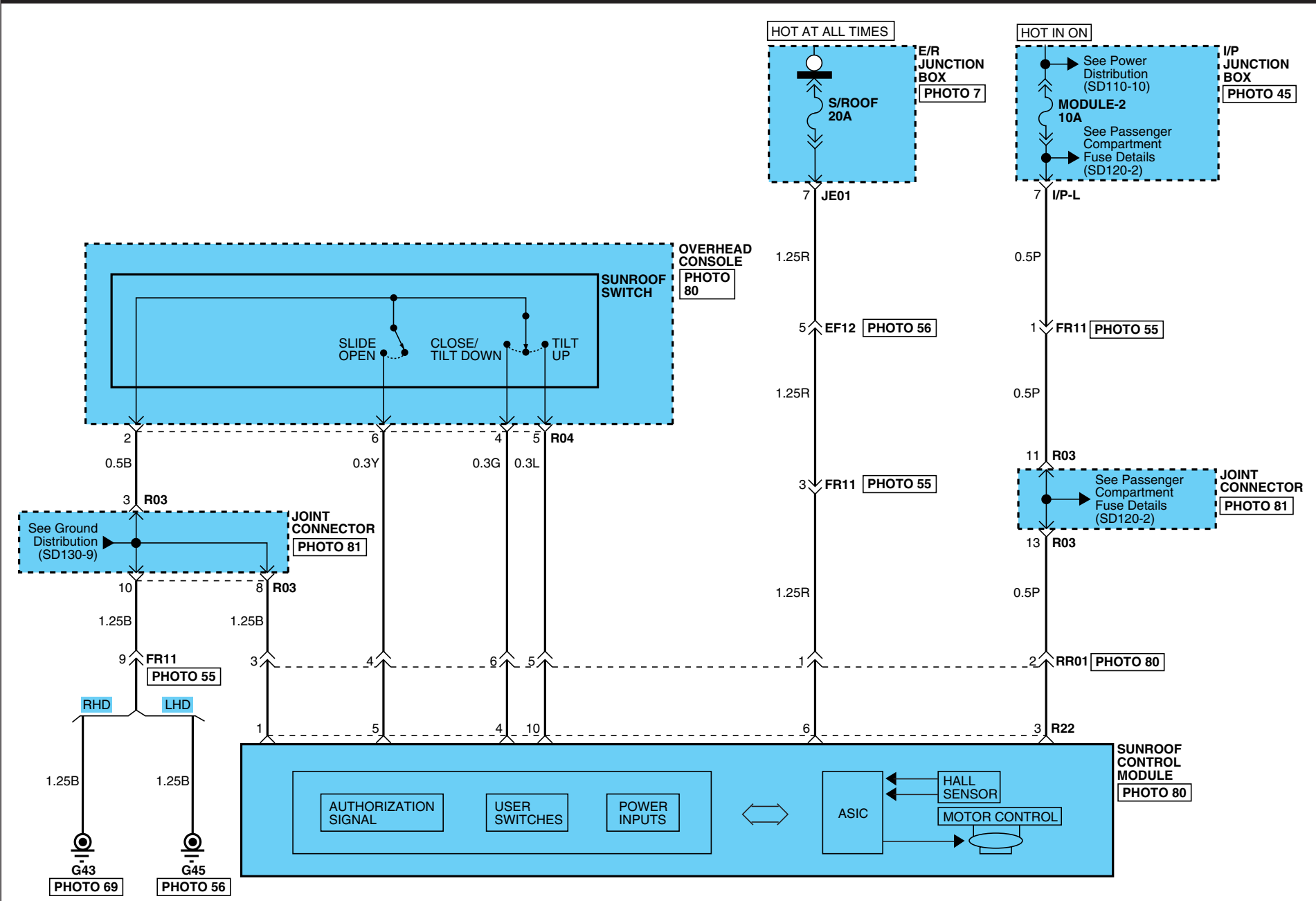

# SUNROOF

Sunroof (2)

SD816-2

R04

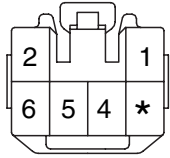

KET\_090II\_06F\_W

R22

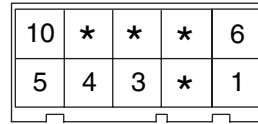

YAZAKI : 7382-6379-30

BLANK

BLANK

Power Windows (1)

SD824-1

LHD

WITH SAFETY WINDOW

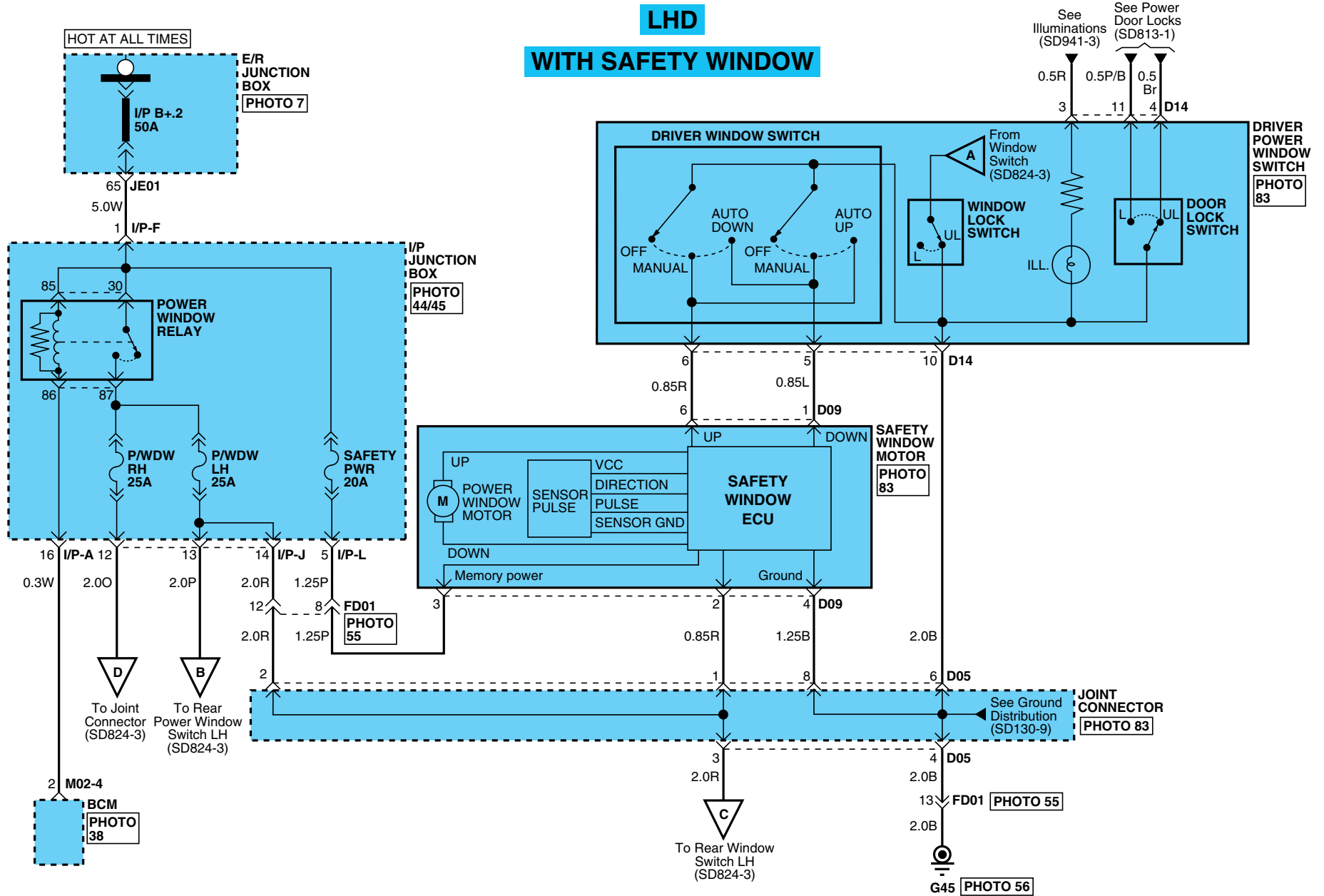







# POWER WINDOWS

## Power Windows (4)

SD824-4

**RHD**

### WITH SAFETY WINDOW

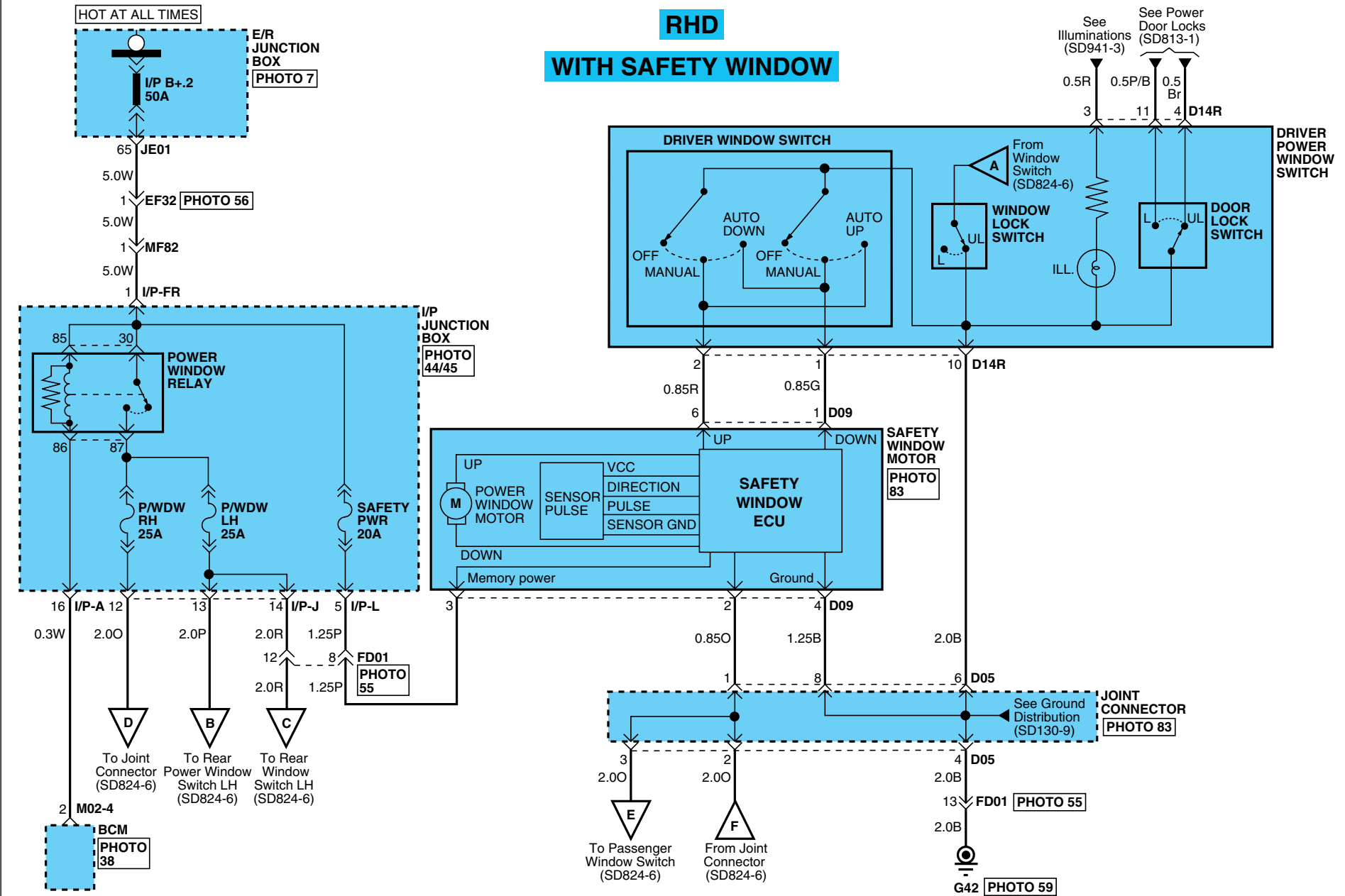

# POWER WINDOWS

## Power Windows (5)

SD824-5

HOT AT ALL TIMES

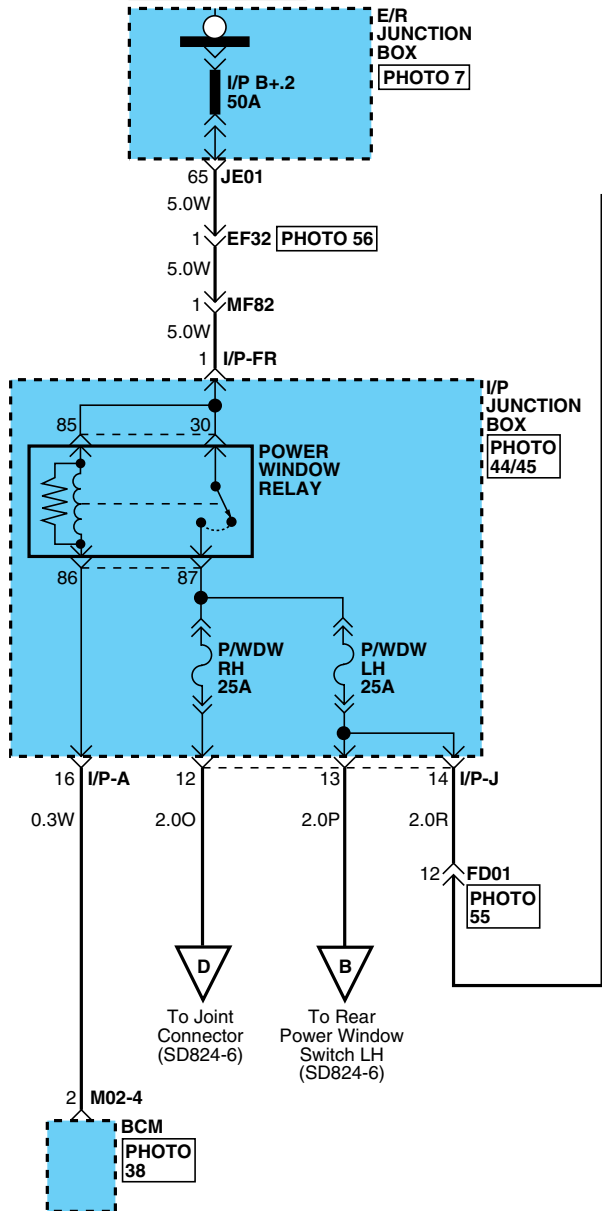

RHD

W/O SAFETY WINDOW

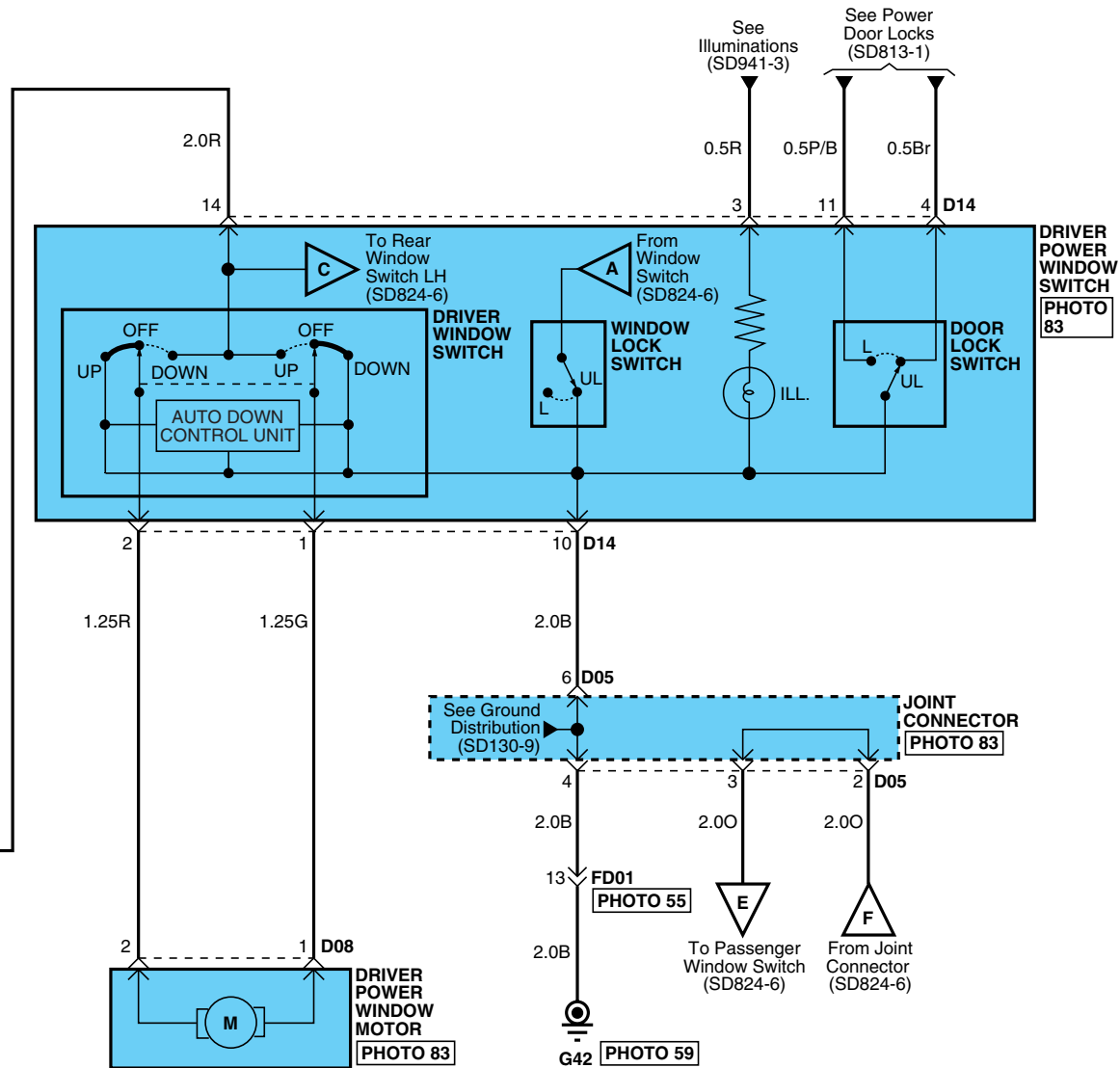

# POWER WINDOWS

## Power Windows (6)

SD824-6

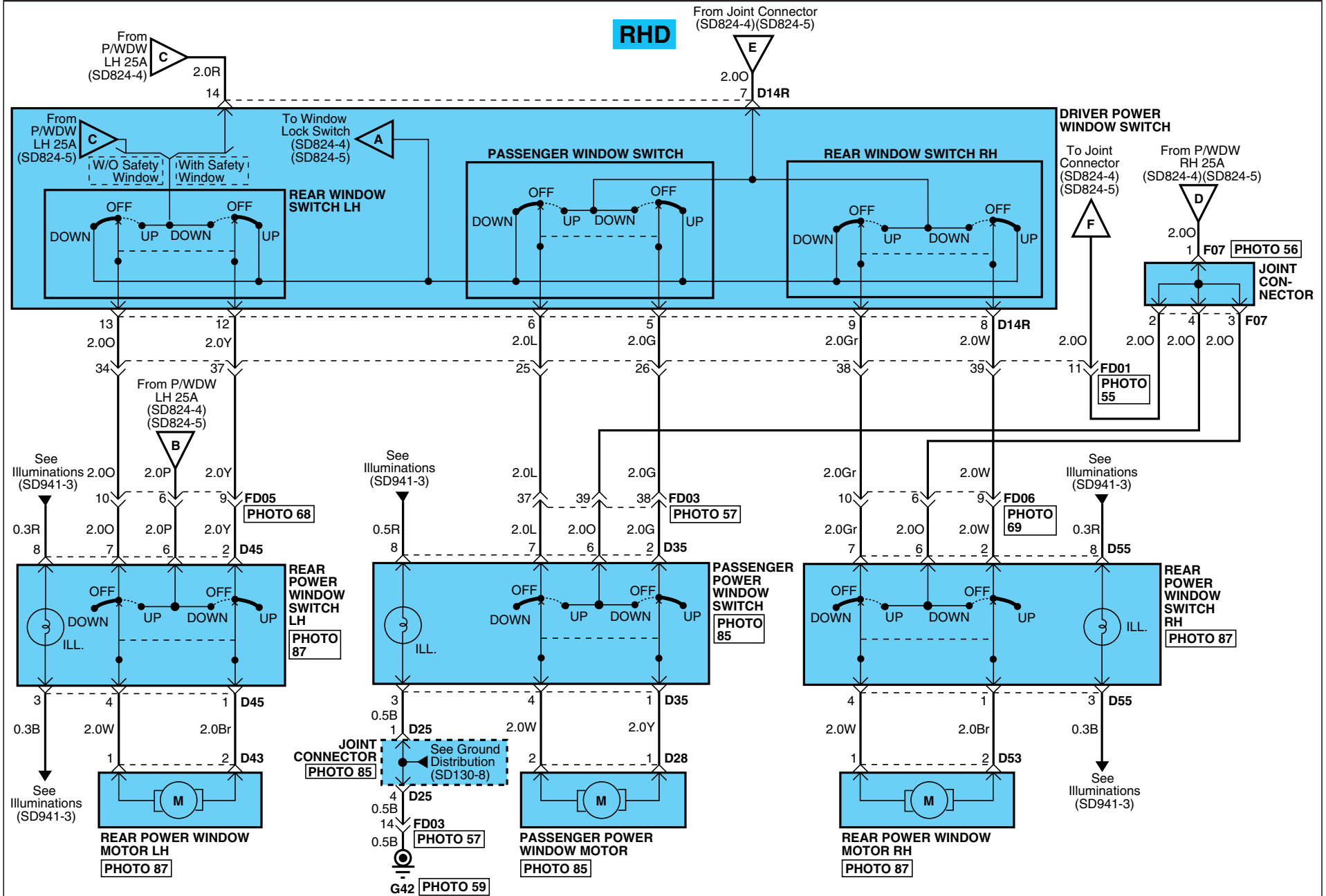

# POWER WINDOWS

## Power Windows (7)

SD824-7

**D08**

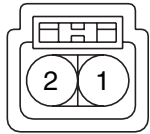

FCI\_SNSR\_02F\_GR

**D09**

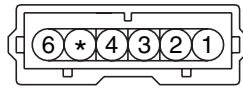

FCI\_SENSOR\_06F\_B

**D14/D14R**

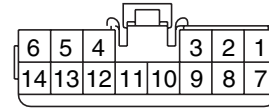

KET\_090II\_14F\_B

**D28**



FCI\_SNSR\_02F\_GR

**D35**

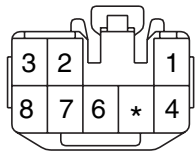

KET\_090II\_08F\_B

**D43**



FCI\_SNSR\_02F\_Gr

**D45**

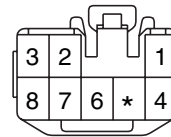

KET\_09II\_08F\_W

**D53**



FCI\_SNSR\_02F\_Gr

**D55**

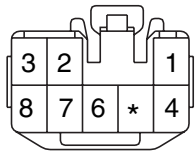

KET\_090II\_08F\_W

**M02-4**

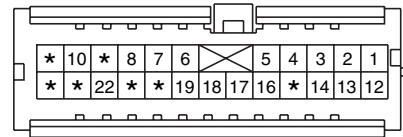

KET\_040III\_24F\_Gr

**BLANK**

**BLANK**

**POWER WINDOWS**

**Power Windows (8)**

**SD824-8**

**MEMO**





# ELECTRO CHROMIC MIRROR

## Electro Chromic Mirror (2)

SD851-2

C36

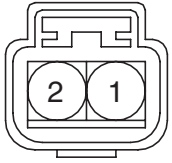

KUM\_NMWP\_02F\_B

C37/C336

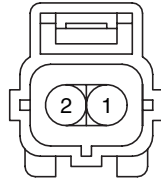

AMP\_EJWP\_02F\_B

C38/C238/C338



KET\_SSD\_10F\_B\_A

R01

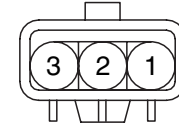

KET\_TLCWP\_03F\_W

Windshield Defogger System (1)

SD861-1

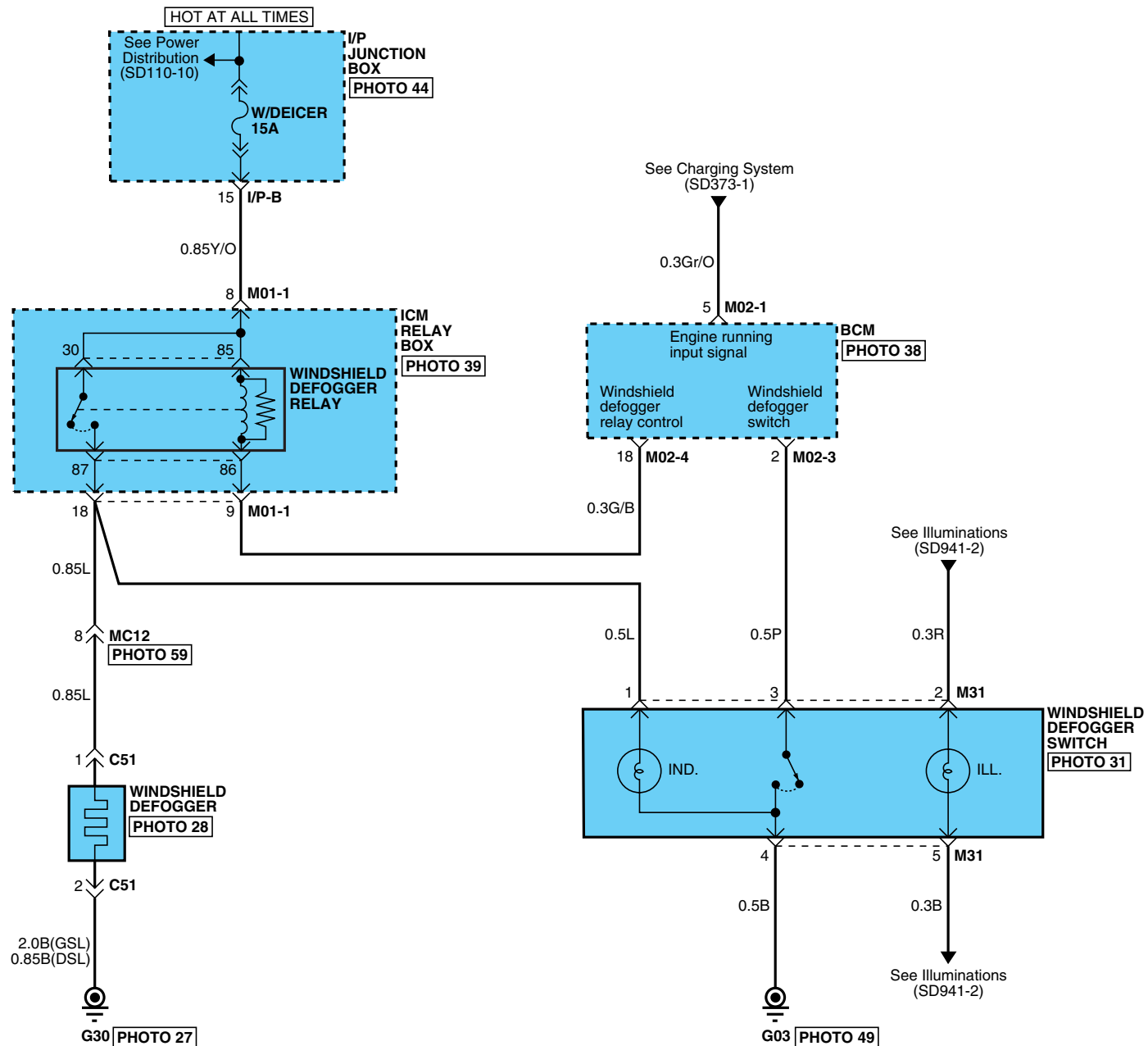

# WINDSHIELD DEFOGGER SYSTEM

## Windshield Defogger System (2)

SD861-2

**C51**

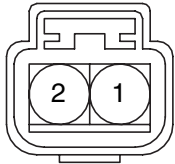

KUM\_NMWP\_02F\_B

**M01-1**

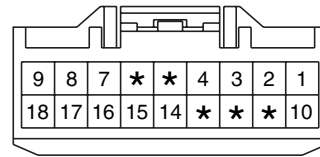

AMP\_090III\_18F\_W

**M02-1**

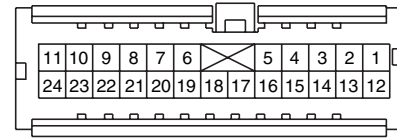

KET\_040III\_24F\_W

**M02-3**

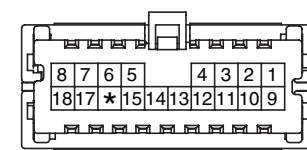

KET\_040III\_18F\_W

**M02-4**

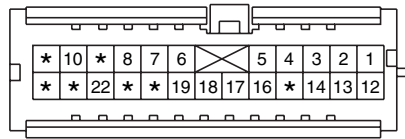

KET\_040III\_24F\_Gr

**M31**

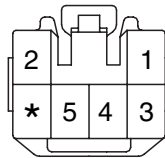

KET\_090II\_06F\_R

**BLANK**

**BLANK**

Power Outside Mirror & Mirror Folding System (1)

SD876-1

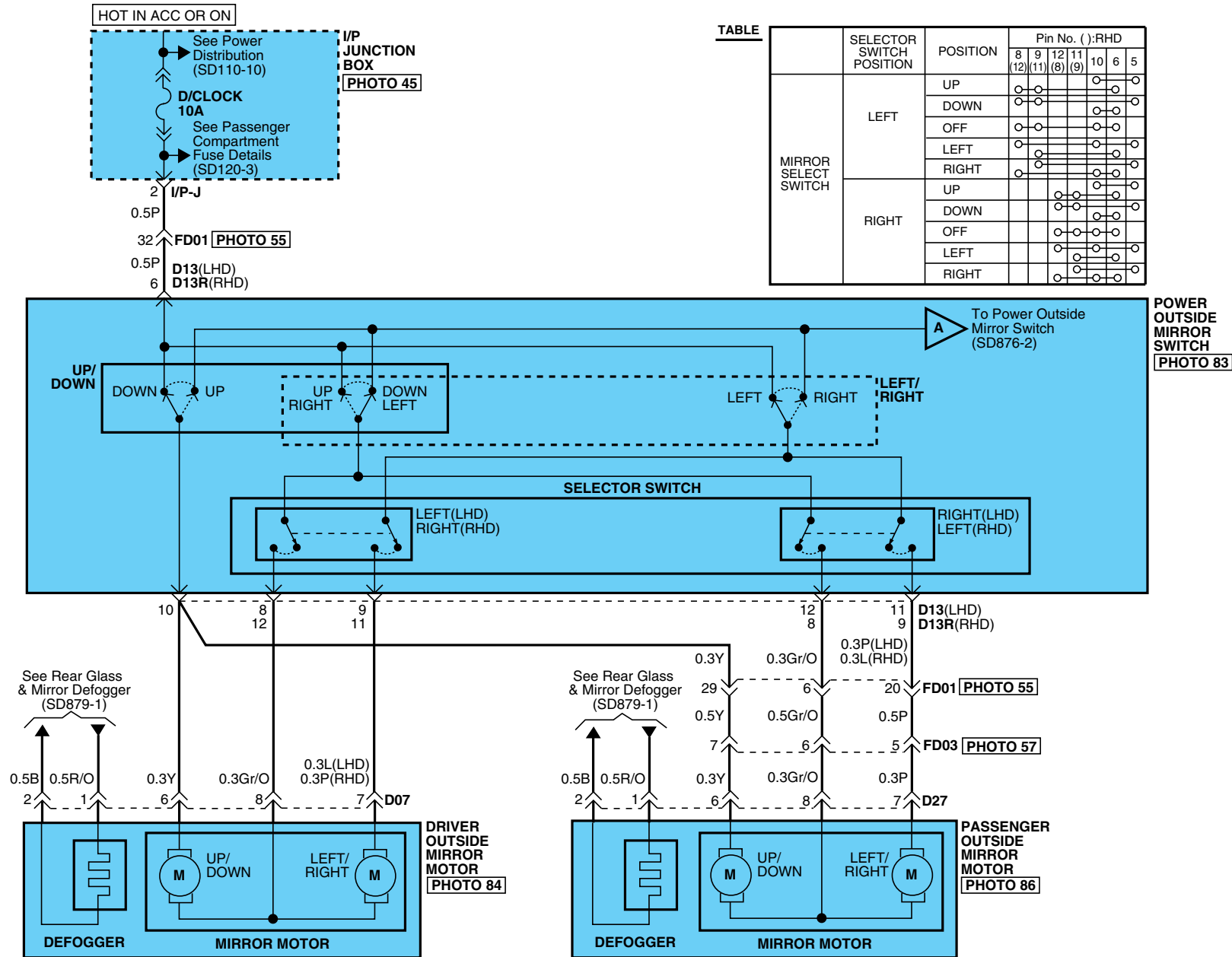

# POWER OUTSIDE MIRROR & MIRROR FOLDING SYSTEM

## Power Outside Mirror & Mirror Folding System (2)

SD876-2

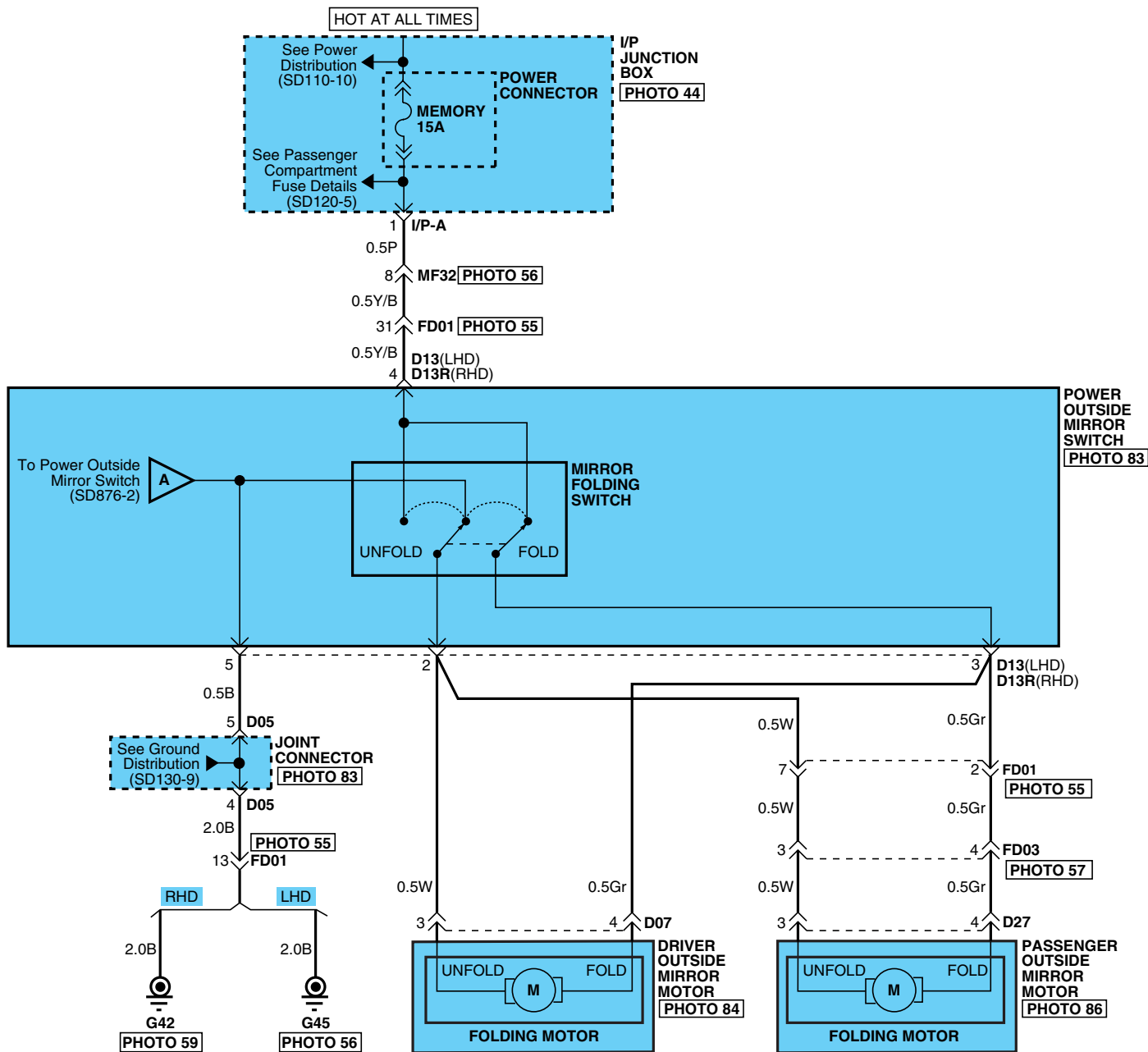

# POWER OUTSIDE MIRROR & MIRROR FOLDING SYSTEM

## Power Outside Mirror & Mirror Folding System (3)

SD876-3

D07

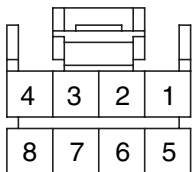

AMP\_040M1\_08F\_B

D13/D13R

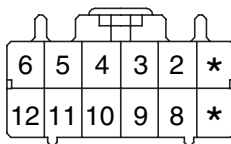

AMP\_070\_12F\_Gr\_HD

D27

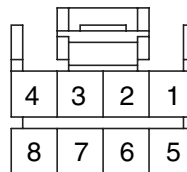

AMP\_040M1\_08F\_B

BLANK

**POWER OUTSIDE MIRROR & MIRROR FOLDING SYSTEM**

**Power Outside Mirror & Mirror Folding System (4)**

**SD876-4**

**MEMO**

# REAR GLASS & MIRROR DEFOGGER

EFFAAA21

## Rear Glass & Mirror Defogger (1)

SD879-1

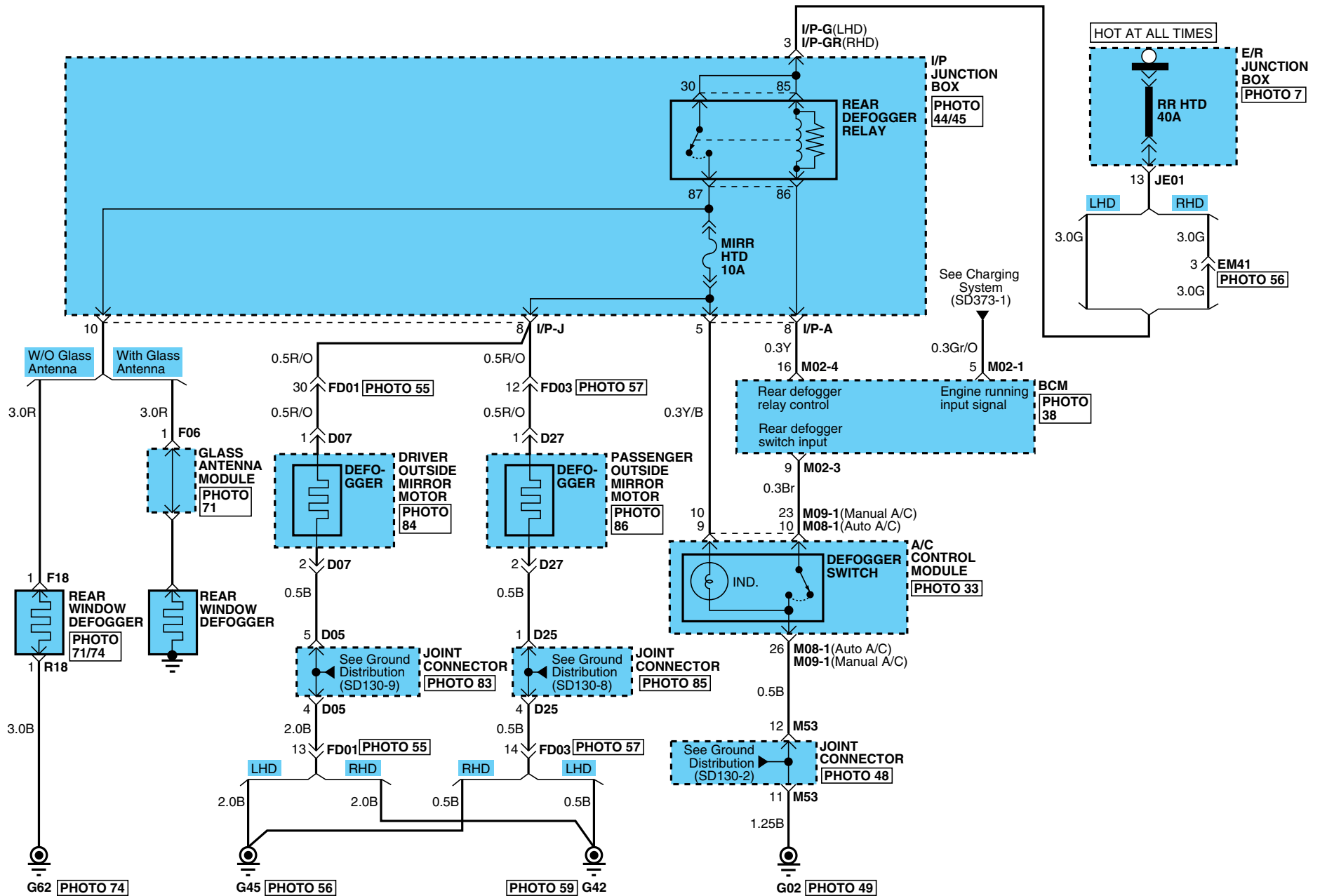



# REAR GLASS & MIRROR DEFOGGER

## Rear Glass & Mirror Defogger (2)

SD879-2

**D07**

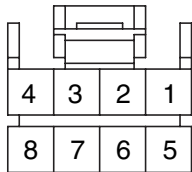

AMP\_040M1\_08F\_B

**D27**

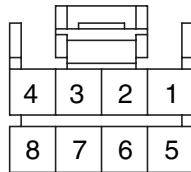

AMP\_040M1\_08F\_B

**F06**

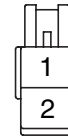

KET\_GLASS\_02F\_B\_ANT

**F18**

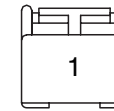

AMP\_PLM2\_01F\_B

**BLANK**

**M02-1**

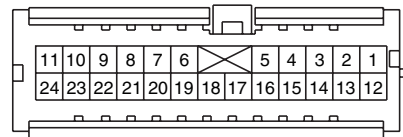

KET\_040III\_24F\_W

**M02-3**

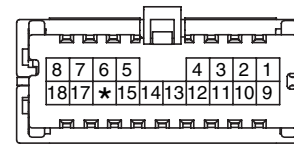

KET\_040III\_18F\_W

**M02-4**

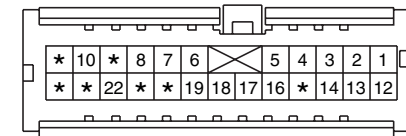

KET\_040III\_24F\_Gr

**M08-1**

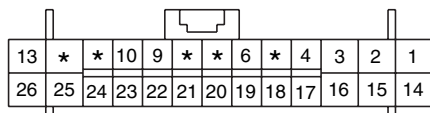

AMP\_0407\_26F\_W\_HD

**M09-1**

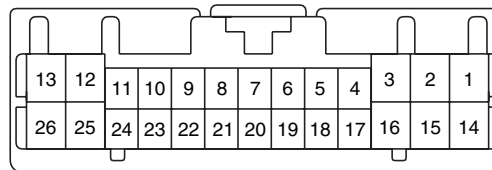

KET\_0407\_26F\_W

**R18**



AMP\_PLM2\_01F\_B

# DRIVER POWER SEAT

EC6F8DF0

## Driver Power Seat (1)

SD880-1

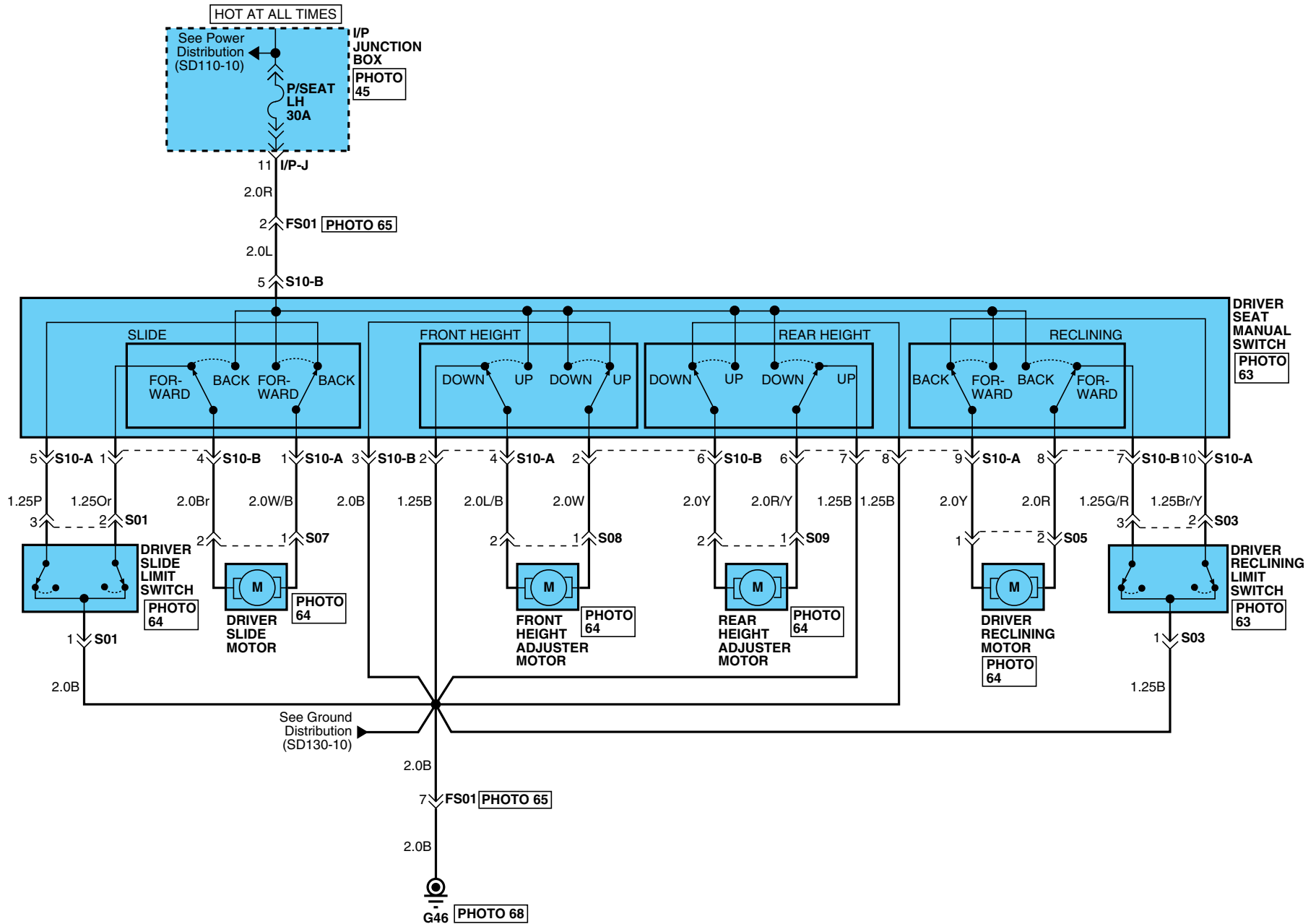

# DRIVER POWER SEAT

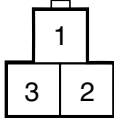
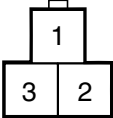
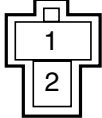
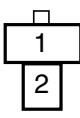
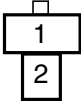
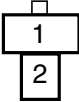
Driver Power Seat (2)			SD880-2																				
<p><b>S01</b></p>  <p>KET_630677_H</p>	<p><b>S03</b></p>  <p>KET_630677_H</p>	<p><b>S05</b></p>  <p>KET_620262_H</p>	<p><b>S07</b></p>  <p>KET_610263_B</p>																				
<p><b>S08</b></p>  <p>KET_610263_H</p>	<p><b>S09</b></p>  <p>KET_610263_5_H</p>	<p><b>S10-A</b></p> <table border="1" data-bbox="1227 568 1456 647"> <tr> <td>4</td> <td>*</td> <td>∇</td> <td>2</td> <td>1</td> </tr> <tr> <td>10</td> <td>9</td> <td>8</td> <td>7</td> <td>6</td> <td>5</td> </tr> </table> <p>KET_610404_H</p>	4	*	∇	2	1	10	9	8	7	6	5	<p><b>S10-B</b></p> <table border="1" data-bbox="1742 568 1908 647"> <tr> <td>3</td> <td>2</td> <td>∇</td> <td>1</td> </tr> <tr> <td>8</td> <td>7</td> <td>6</td> <td>5</td> <td>4</td> </tr> </table> <p>KET_610402_H</p>	3	2	∇	1	8	7	6	5	4
4	*	∇	2	1																			
10	9	8	7	6	5																		
3	2	∇	1																				
8	7	6	5	4																			

# PASSENGER POWER SEAT

E2918EB9

## Passenger Power Seat (1)

SD881-1

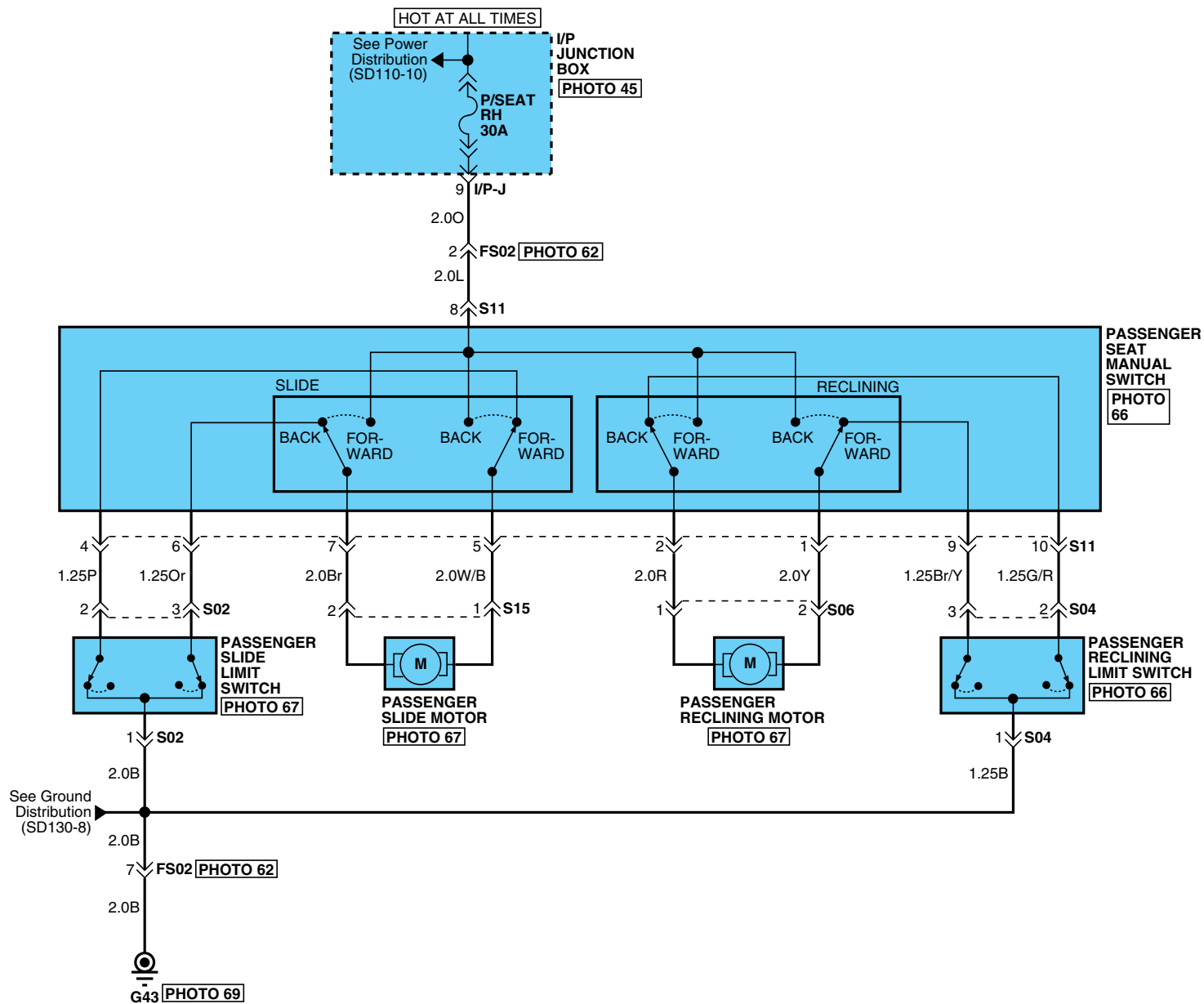

# PASSENGER POWER SEAT

## Passenger Power Seat (2)

SD881-2

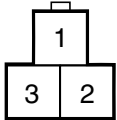
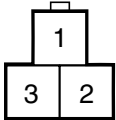
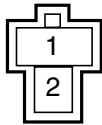
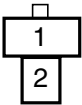
<p>S02</p>  <p>KET_636077_F</p>	<p>S04</p>  <p>KET_636077_F</p>	<p>S06</p>  <p>KET_620262_F</p>	<p>S11</p> <table border="1" data-bbox="1711 300 1942 379"> <tr> <td>4</td> <td>*</td> <td>∇</td> <td>2</td> <td>1</td> </tr> <tr> <td>10</td> <td>9</td> <td>8</td> <td>7</td> <td>6</td> <td>5</td> </tr> </table> <p>KET_610404_F</p>	4	*	∇	2	1	10	9	8	7	6	5
4	*	∇	2	1										
10	9	8	7	6	5									
<p>S15</p>  <p>KET_610263_B</p>	<p><b>BLANK</b></p>	<p><b>BLANK</b></p>	<p><b>BLANK</b></p>											



# SEAT WARMER

## Seat Warmer (2)

SD889-2

**M01-1**

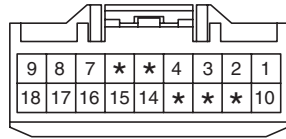

AMP\_090III\_18F\_W

**M41**

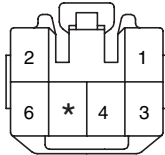

KET\_090II\_06F\_B

**M42**

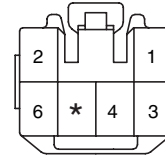

KET\_090II\_06F\_W

**S19**

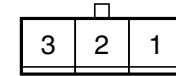

KET\_651032\_W

**S20**

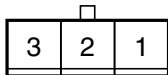

KET\_651032\_W

**BLANK**

**BLANK**

**BLANK**

Head Lamps (1)

SD921-1

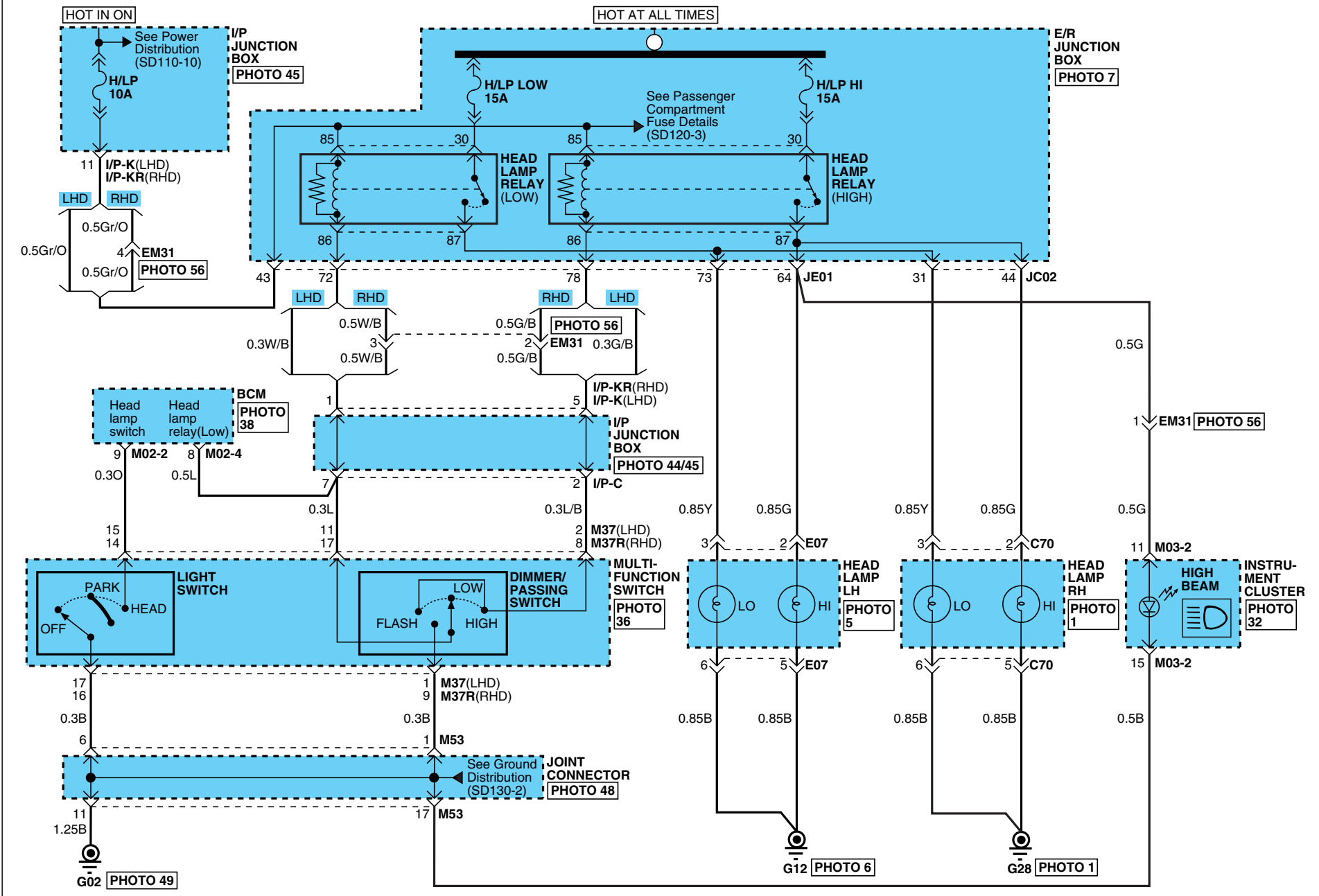



# HEAD LAMPS

## Head Lamps (2)

SD921-2

**C70**



KUM\_NMWP\_06F\_B

**E07**

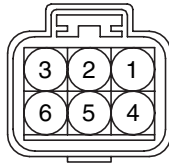

KUM\_NMWP\_06F\_B

**M02-2**

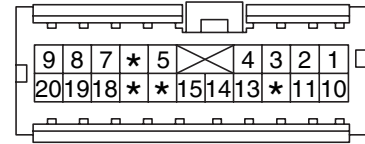

KET\_040III\_20F\_W

**M02-4**

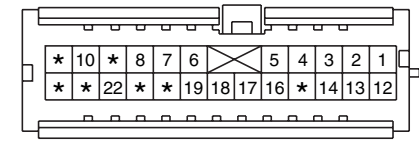

KET\_040III\_24F\_Gr

**M03-2**

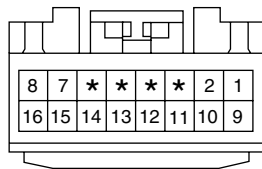

MLX\_040III\_16F\_Gr

**M37**

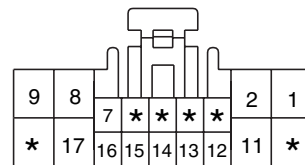

KET\_0509\_18F\_W

**M37R**

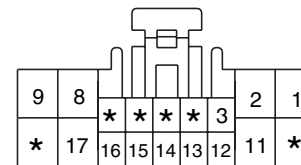

KET\_0509\_18F\_W

**BLANK**

Head Lamp Leveling Device (1)

SD922-1

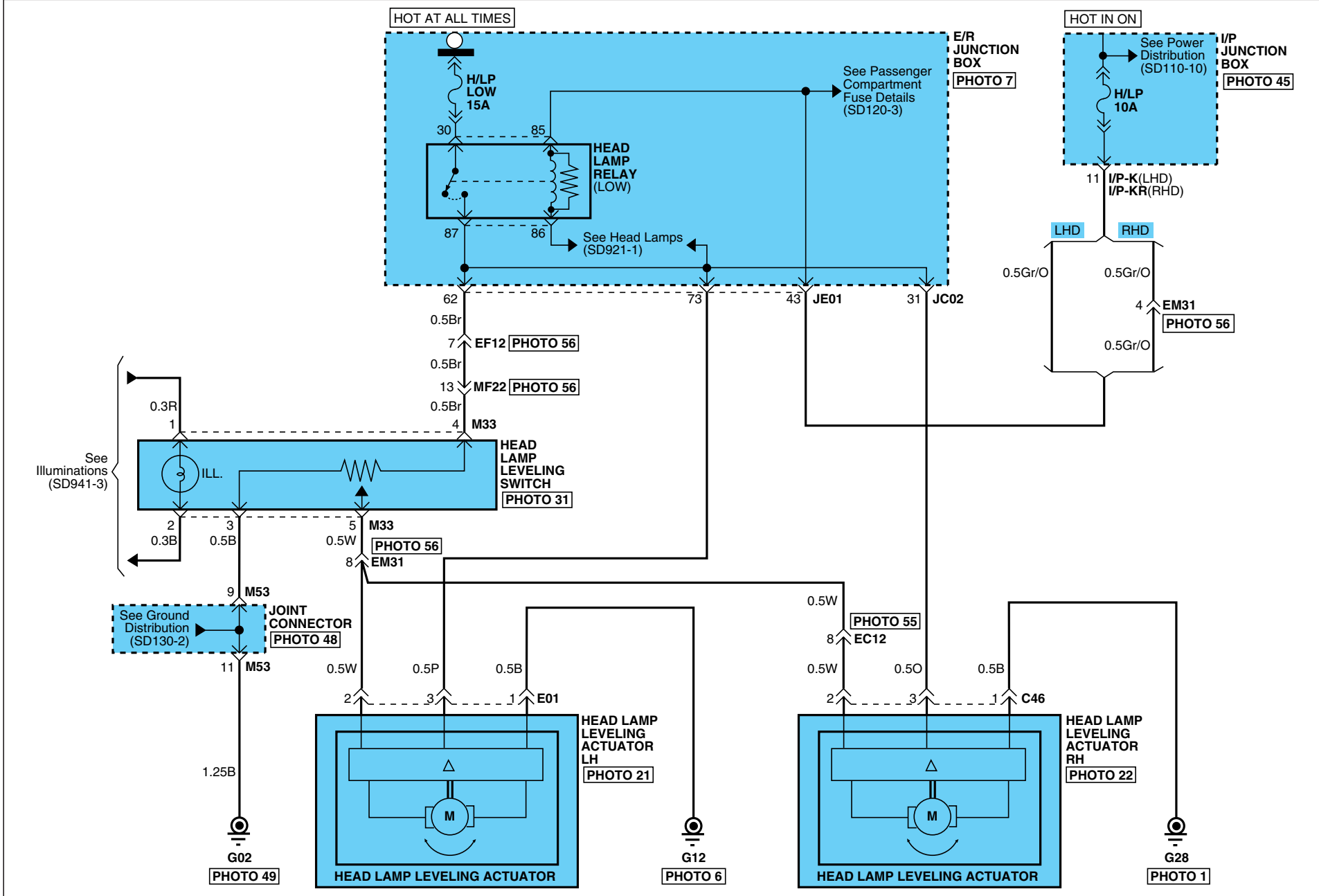

# HEAD LAMP LEVELING DEVICE

## Head Lamp Leveling Device (2)

SD922-2

C46

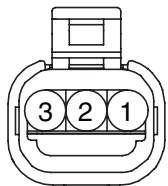

AMP\_025WP\_03F\_B

E01

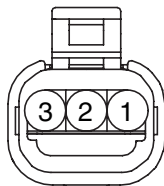

AMP\_025WP\_03F\_B

M33

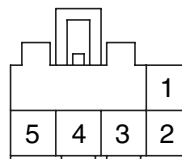

KUM\_CDR\_05F\_W

BLANK



# FRONT FOG & REAR FOG LAMPS

## Front Fog & Rear Fog Lamps (2)

SD924-2

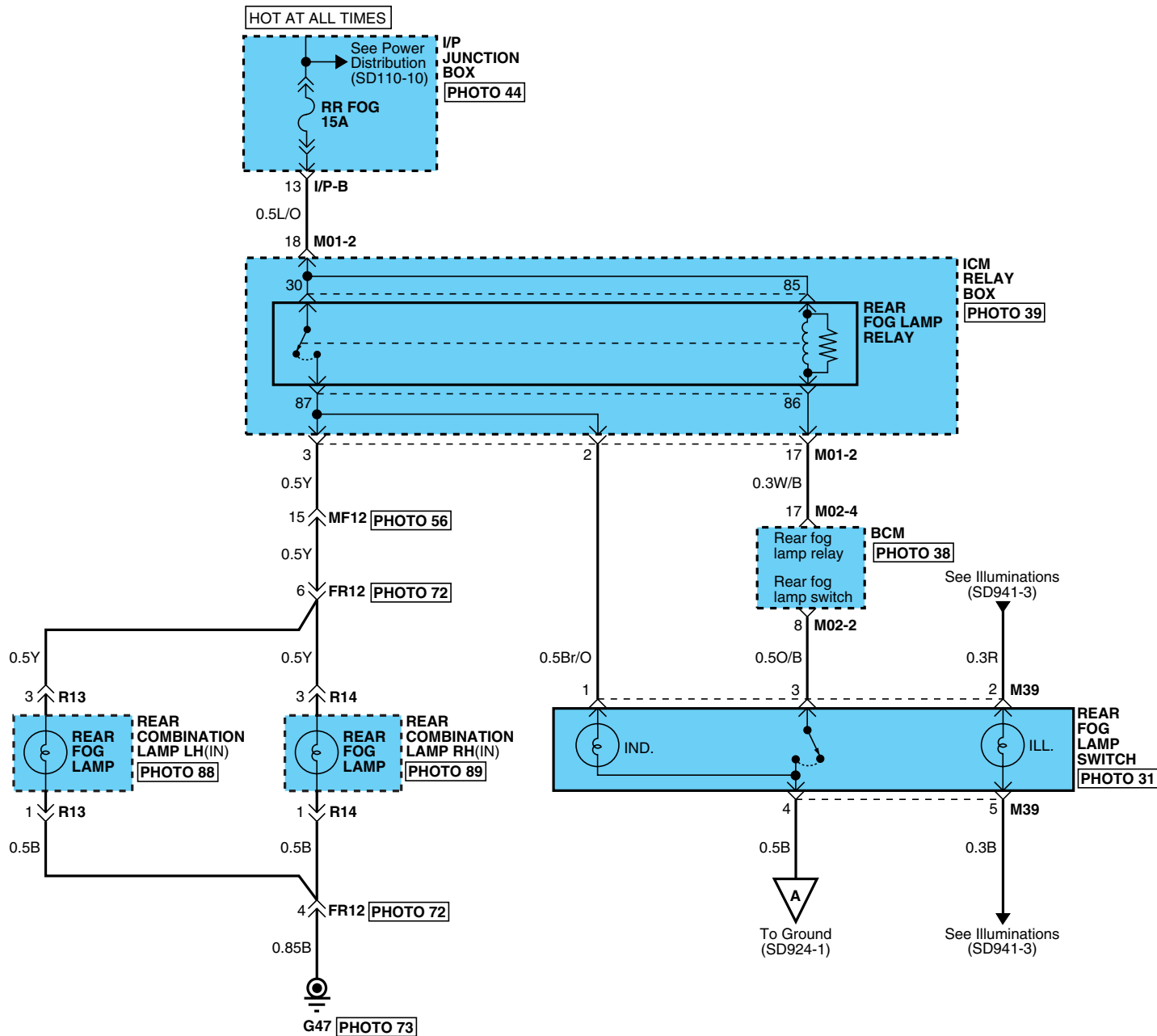

# FRONT FOG & REAR FOG LAMPS

## Front Fog & Rear Fog Lamps (3)

SD924-3

**C60**



KET\_110WP\_02F\_FOG

**E09**



KET\_110WP\_02F\_FOG

**M01-2**

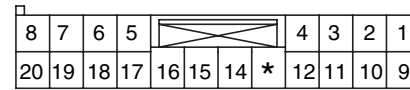

AMP\_0925\_20F\_W

**M02-2**

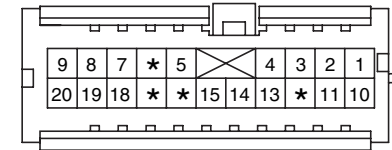

KET\_040III\_20F\_W

**M02-4**

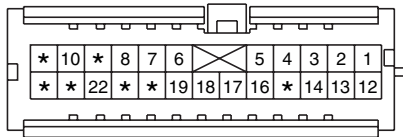

KET\_040III\_24F\_Gr

**M03-1**

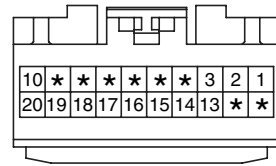

MLX\_040III\_20F\_Gr

**M03-2**

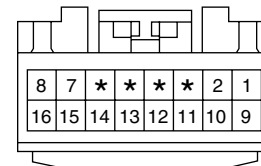

MLX\_040III\_16F\_Gr

**M37**

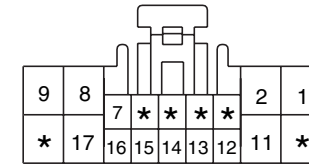

KET\_0509\_18F\_W

**M37R**

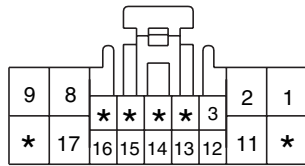

KET\_0509\_18F\_W

**M39**

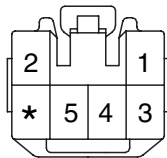

KET\_090II\_06F\_L

**R13**

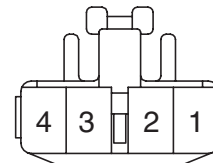

KET\_090II\_04F\_W

**R14**

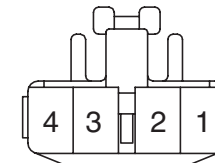

KET\_090II\_04F\_W

**FRONT FOG & REAR FOG LAMPS**

**Front Fog & Rear Fog Lamps (4)**

**SD924-4**

**MEMO**

Turn & Hazard Lamps (1)

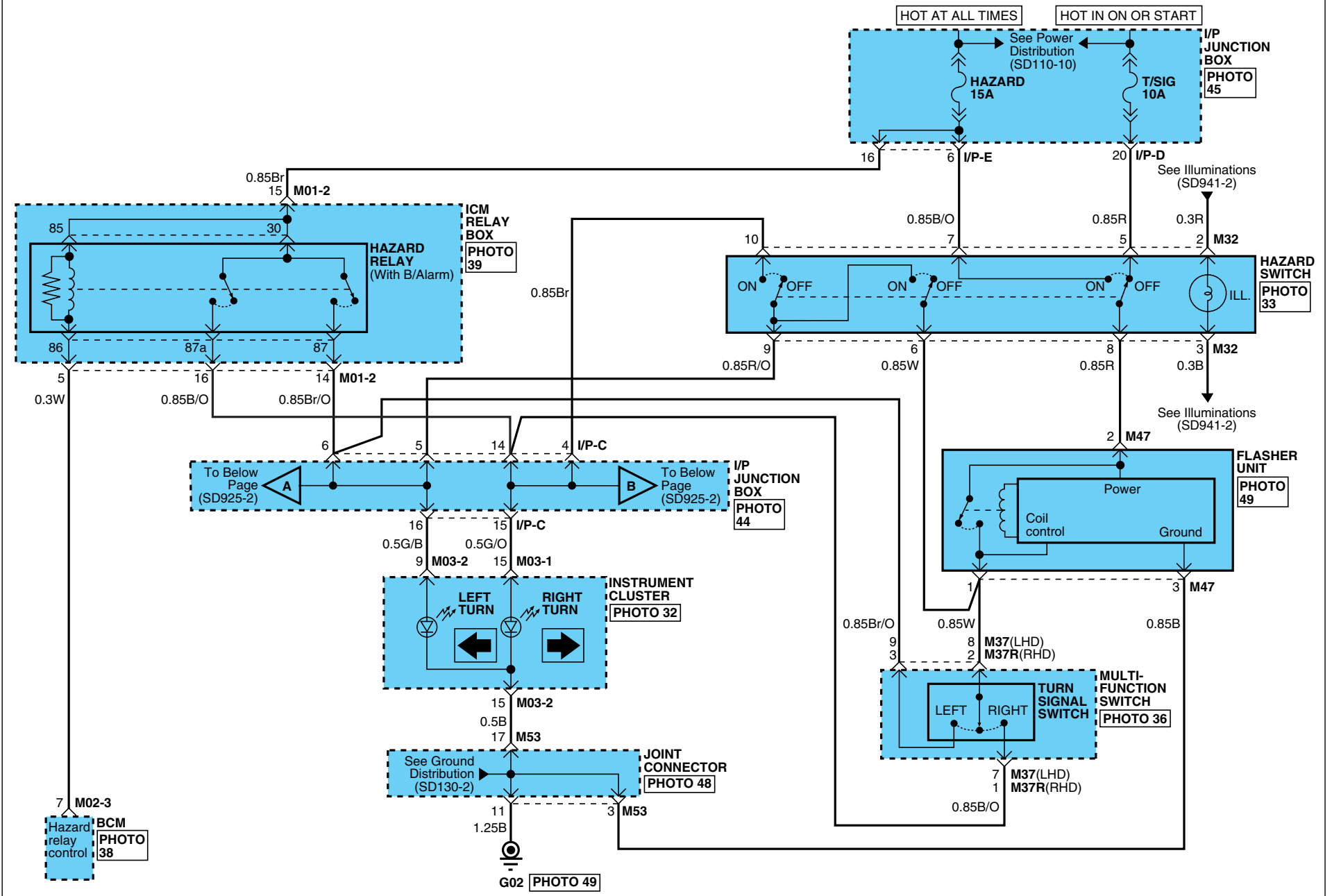



# TURN & HAZARD LAMPS

## Turn & Hazard Lamps (2)

SD925-2

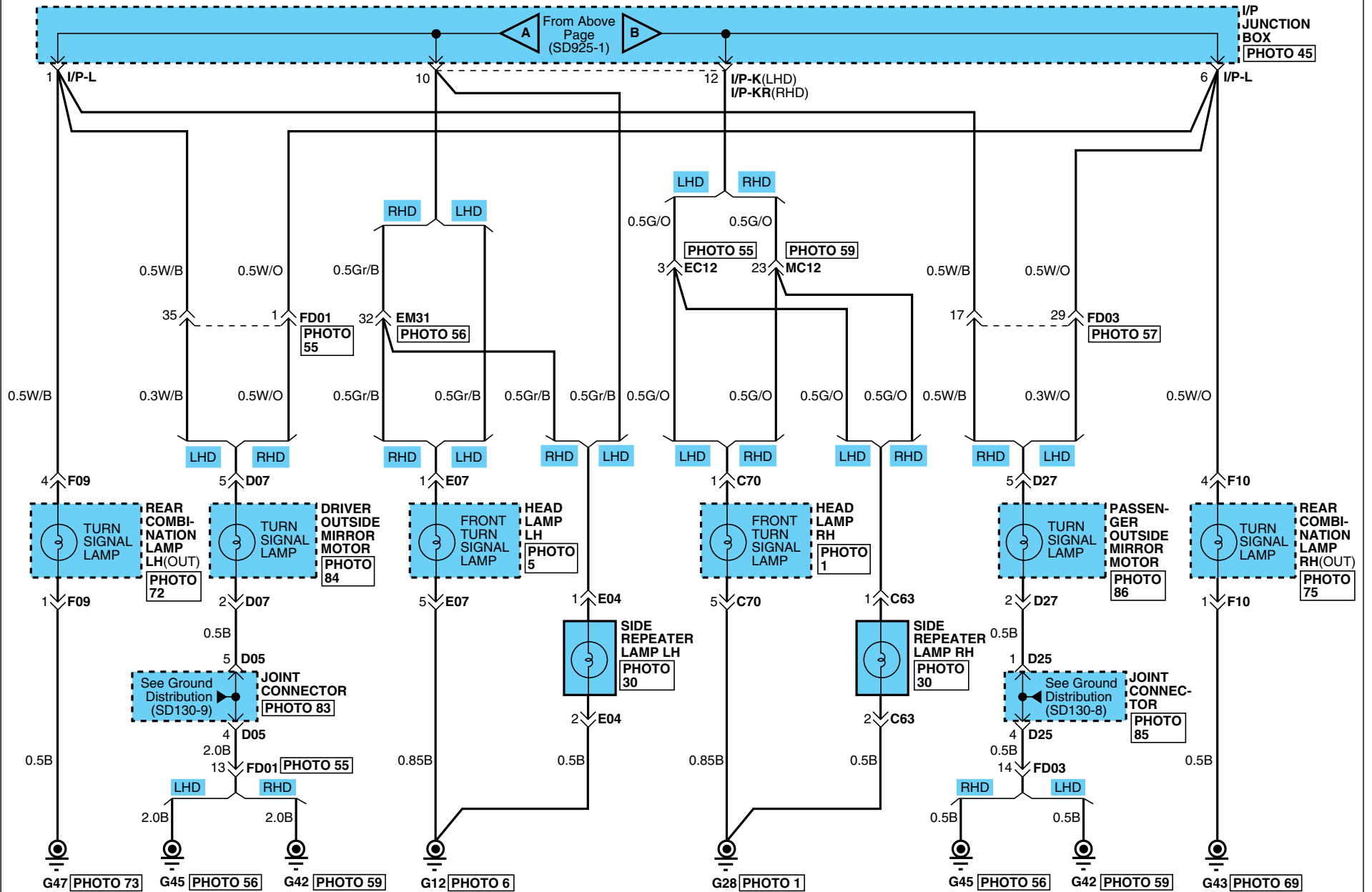

# TURN & HAZARD LAMPS

## Turn & Hazard Lamps (3)

SD925-3

**C63**

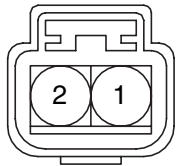

KUM\_NMWP\_02F\_B

**C70**

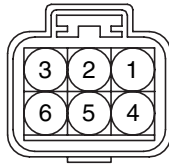

KUM\_NMWP\_06F\_B

**D07**

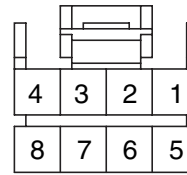

AMP\_040M1\_08F\_B

**D27**

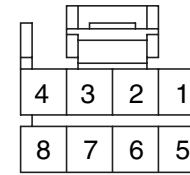

AMP\_040M1\_08F\_B

**E04**

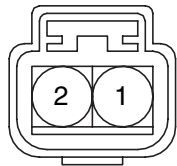

KUM\_NMWP\_02F\_B

**E07**

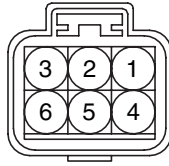

KUM\_NMWP\_06F\_B

**F09**

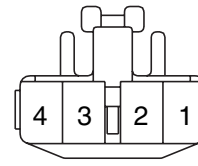

KET\_090II\_04F\_W

**F10**

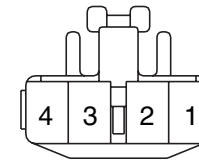

KET\_090II\_04F\_W

**M01-2**

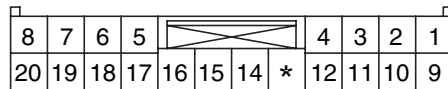

AMP\_0925\_20F\_W

**M02-3**

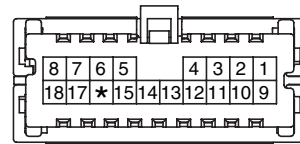

KET\_040III\_18F\_W

**M03-1**

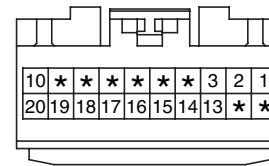

MLX\_040III\_20F\_Gr

**M03-2**

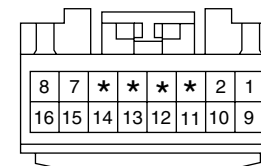

MLX\_040III\_16F\_Gr

**M32**

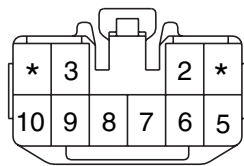

KET\_090II\_10F\_W

**M37**

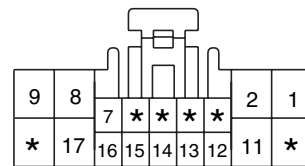

KET\_0509\_18F\_W

**M37R**

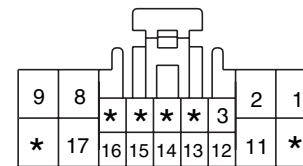

KET\_0509\_18F\_W

**M47**

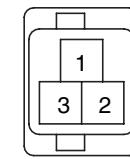

AMP\_250\_03F\_B\_RLY

**TURN & HAZARD LAMPS**

Turn & Hazard Lamps (4)

SD925-4

MEMO

Back-Up Lamps (1)

SD926-1

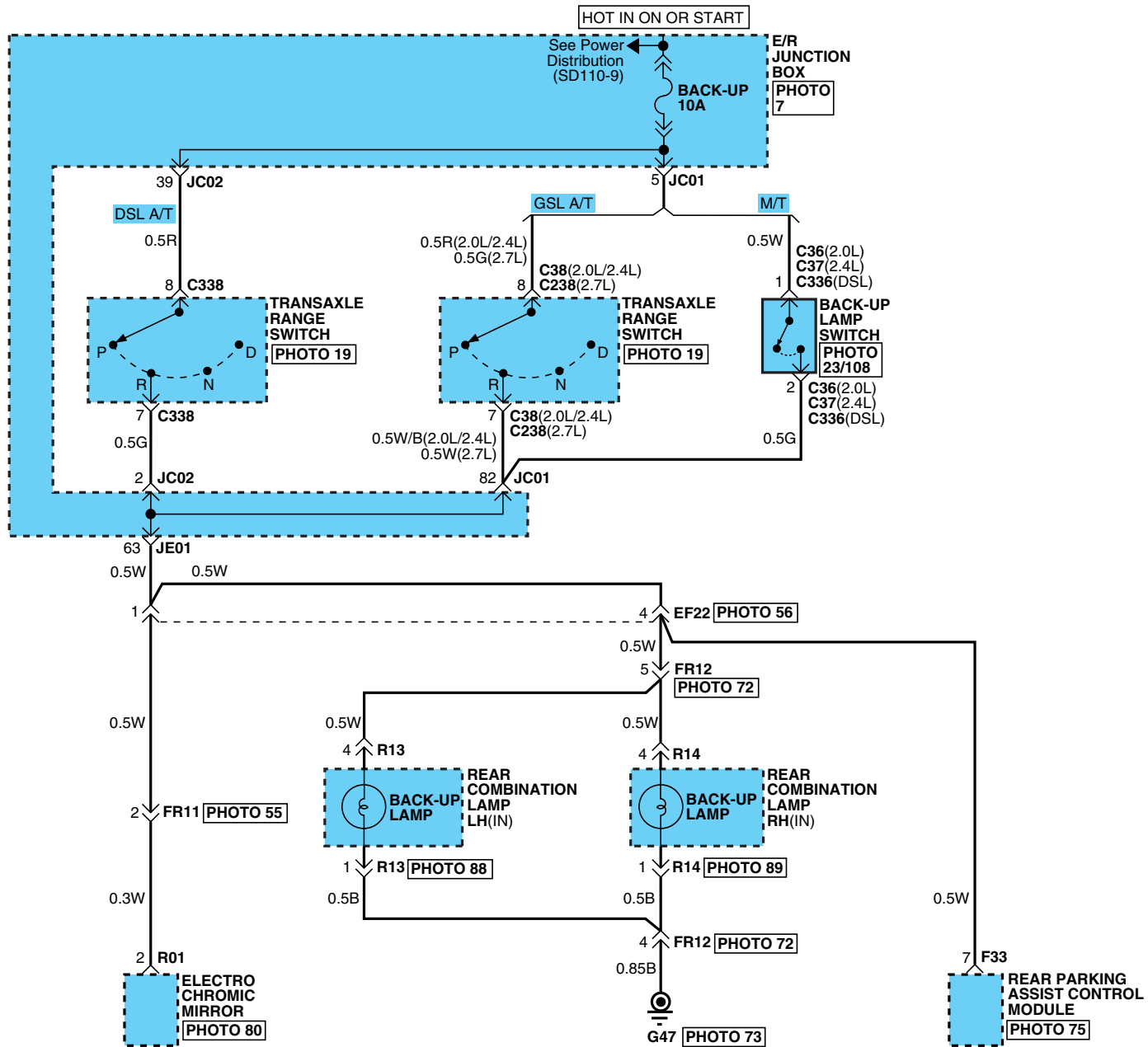

# BACK-UP LAMPS

## Back-Up Lamps (2)

SD926-2

**C36**

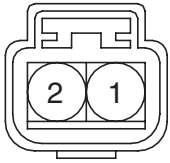

KUM\_NMWP\_02F\_B

**C37/C336**

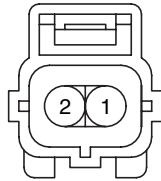

AMP\_EJWP\_02F\_B

**C38/C238/C338**



KET\_SSD\_10F\_B\_A

**F33**

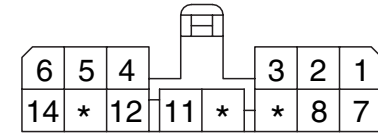

AMP\_070\_14F\_W

**M07-A**

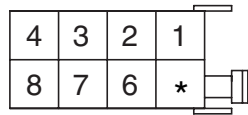

AMP\_JT\_08F\_Gr

**R01**

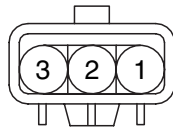

KET\_TLCWP\_03F\_W

**R13**

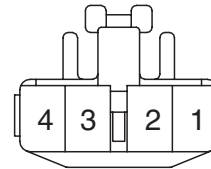

KET\_090II\_04F\_W

**R14**

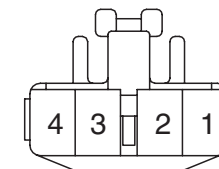

KET\_09III\_04F\_W

Stop Lamps (1)

SD927-1

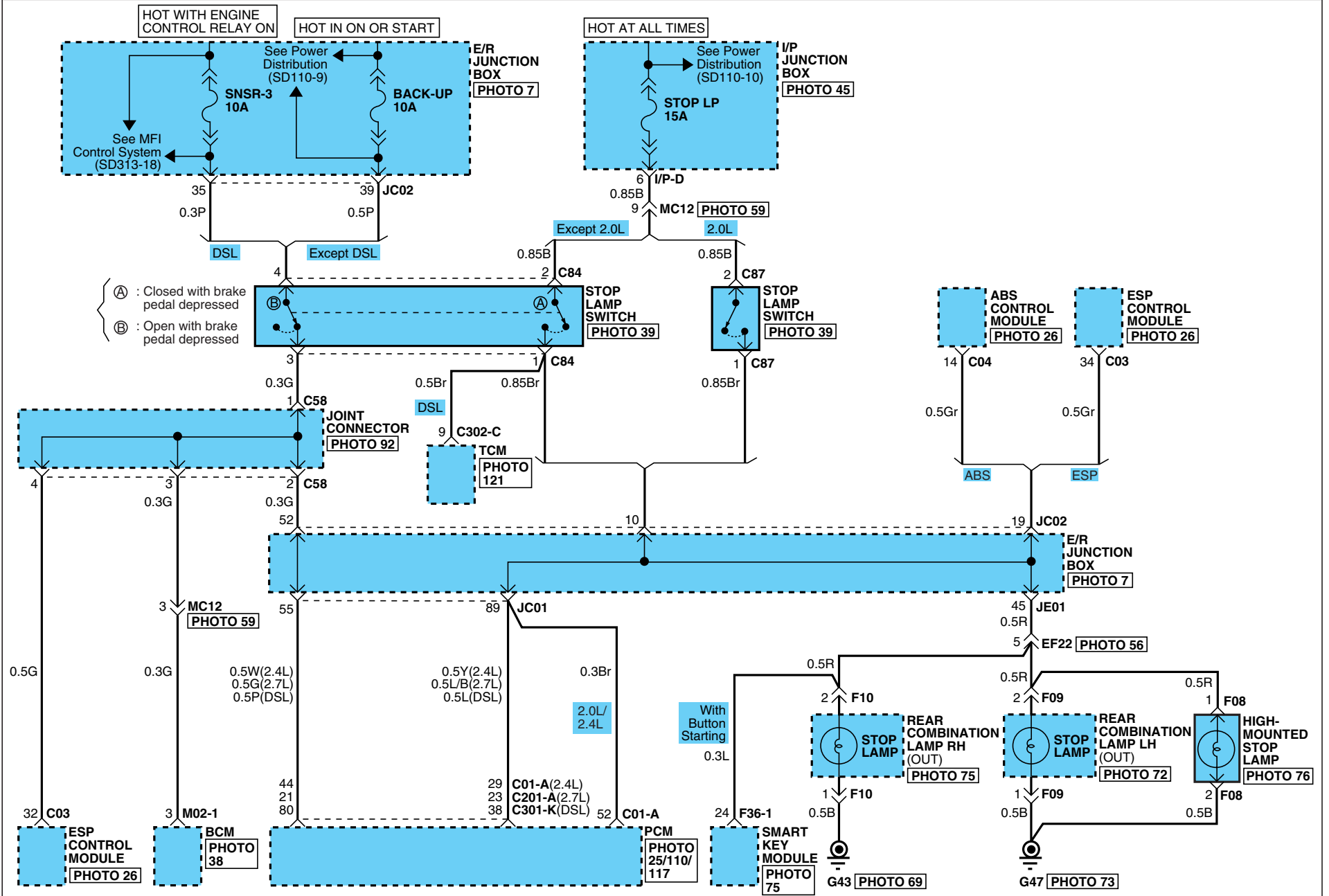



Tail, Parking & License Lamps (1)

SD928-1

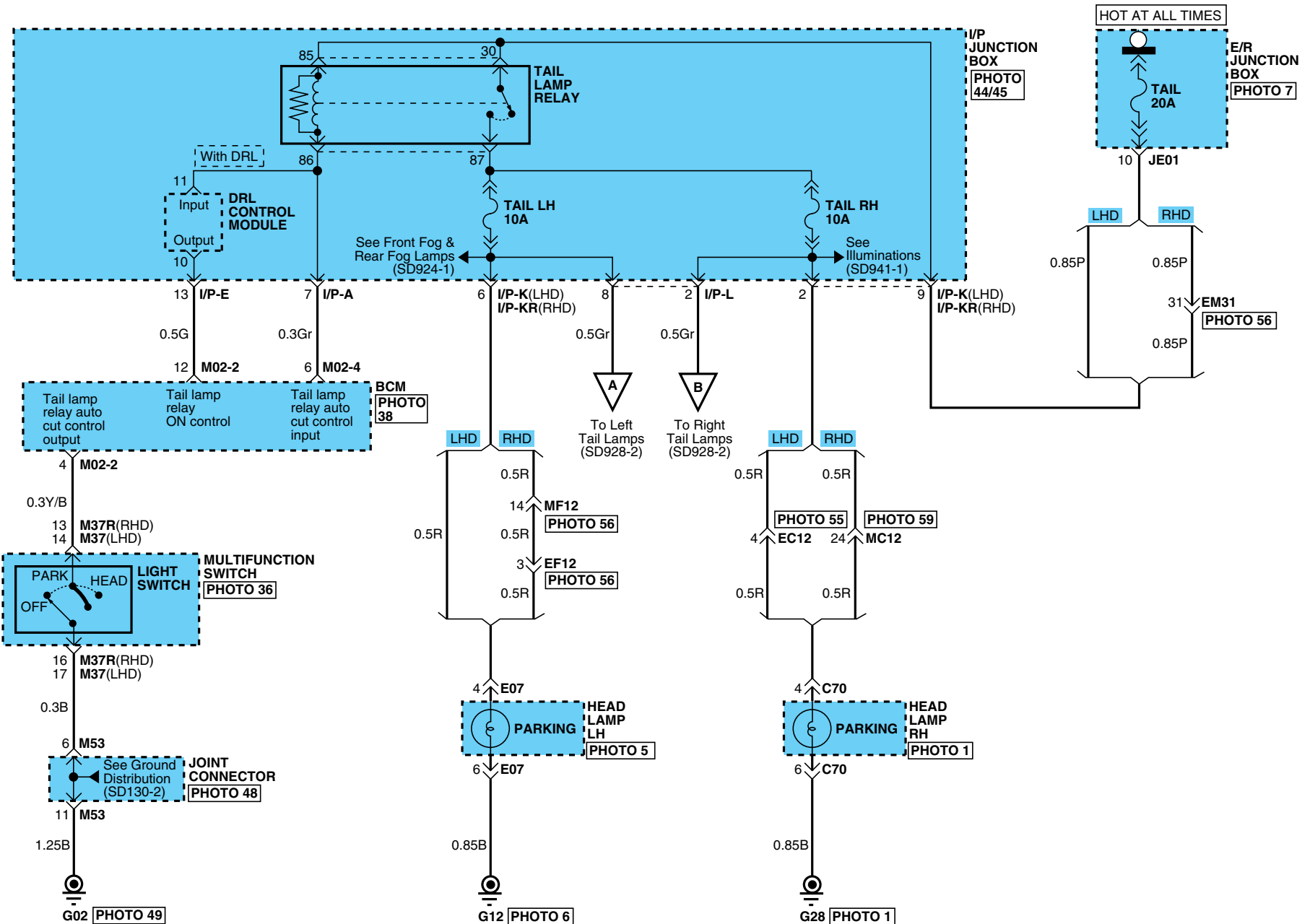



# TAIL, PARKING & LICENSE LAMPS

## Tail, Parking & License Lamps (2)

SD928-2

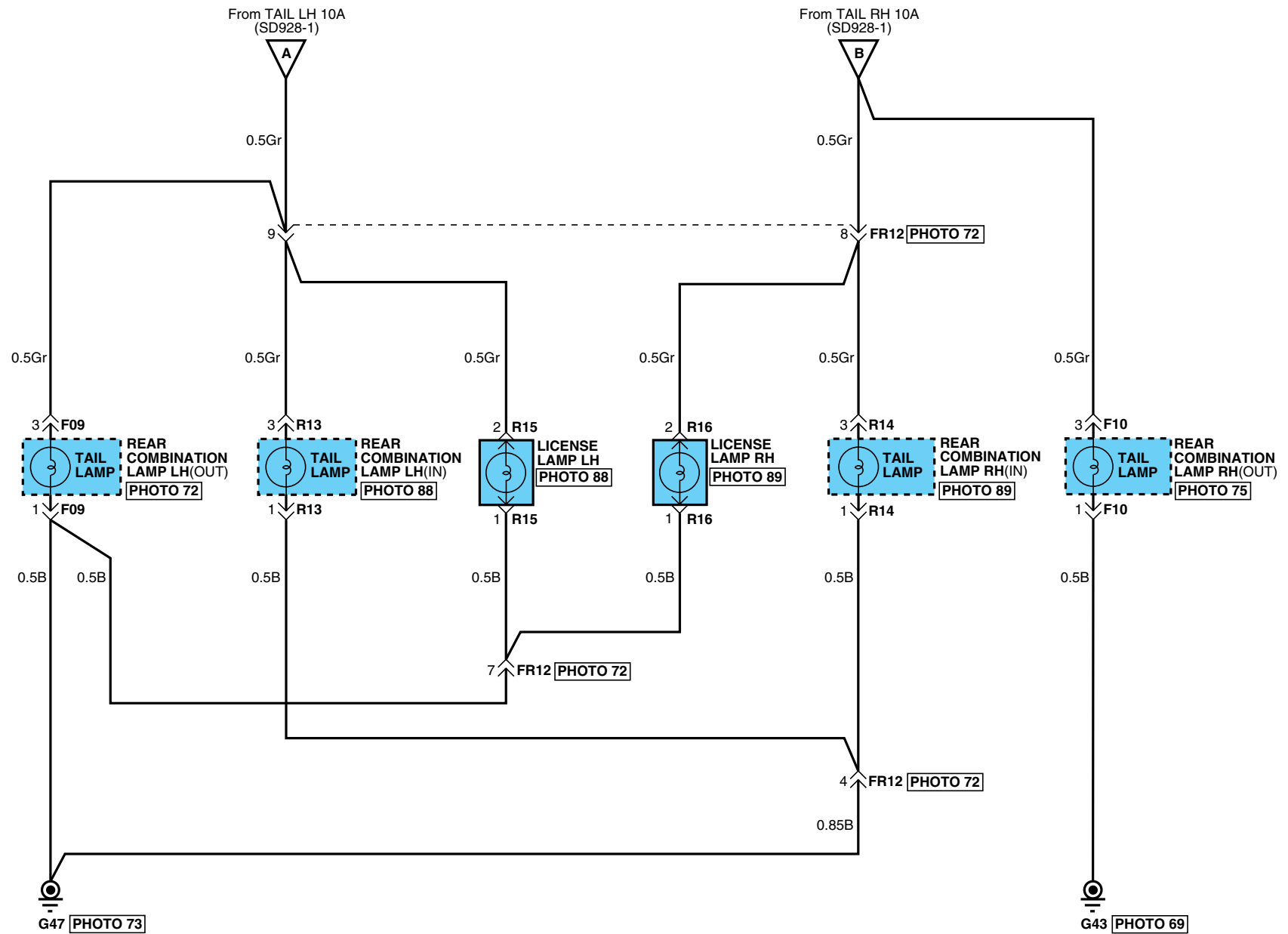

# TAIL, PARKING & LICENSE LAMPS

## Tail, Parking & License Lamps (3)

SD928-3

**C70**



KUM\_NMWP\_06F\_B

**E07**

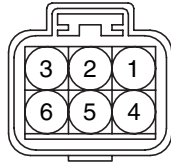

KUM\_NMWP\_06F\_B

**F09**

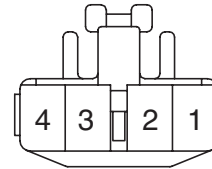

KET\_090III\_04F\_W

**F10**

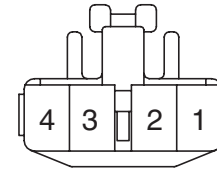

KET\_090III\_04F\_W

**M02-2**

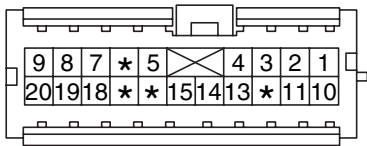

KET\_040III\_20F\_W

**M02-4**

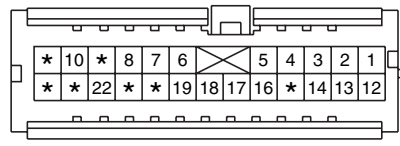

KET\_040III\_24F\_Gr

**M37**

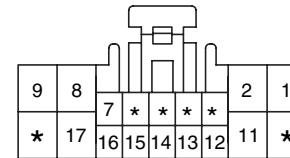

KET\_0509\_18F\_W

**M37R**

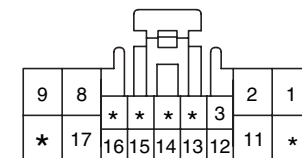

KET\_0509\_18F\_W

**R13**

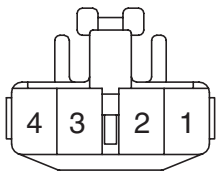

KET\_090III\_04F\_W

**R14**

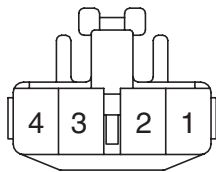

KET\_090III\_04F\_W

**R15**

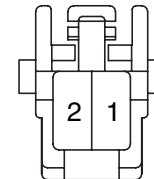

KET\_050\_02F\_W

**R16**

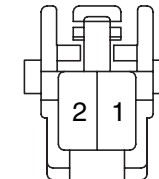

KET\_050\_02F\_W

**TAIL, PARKING & LICENSE LAMPS**

**Tail, Parking & License Lamps (4)**

**SD928-4**

**MEMO**

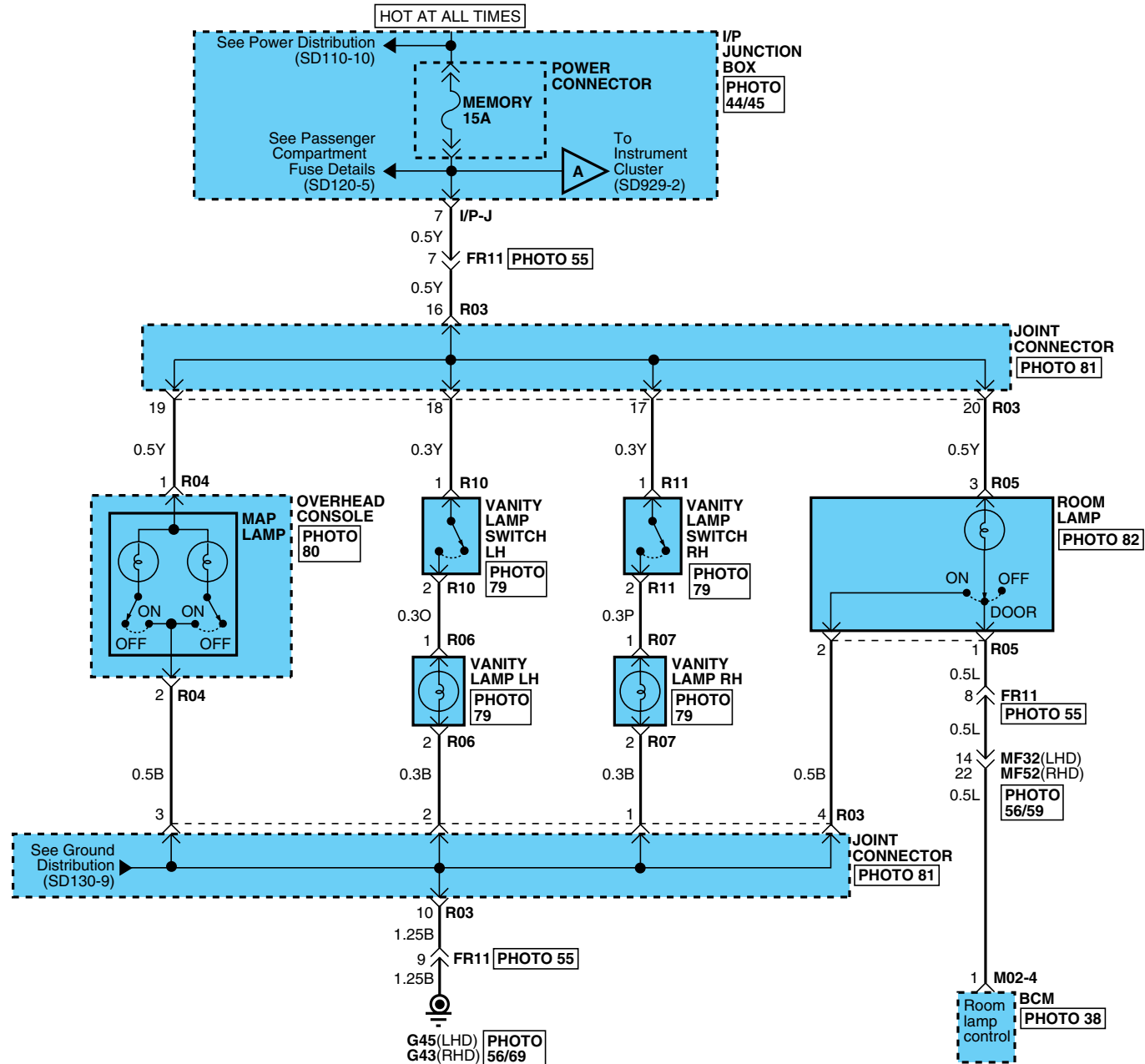



# COURTESY & TRUNK LAMPS

## Courtesy & Trunk Lamps (3)

SD929-3

**RHD**

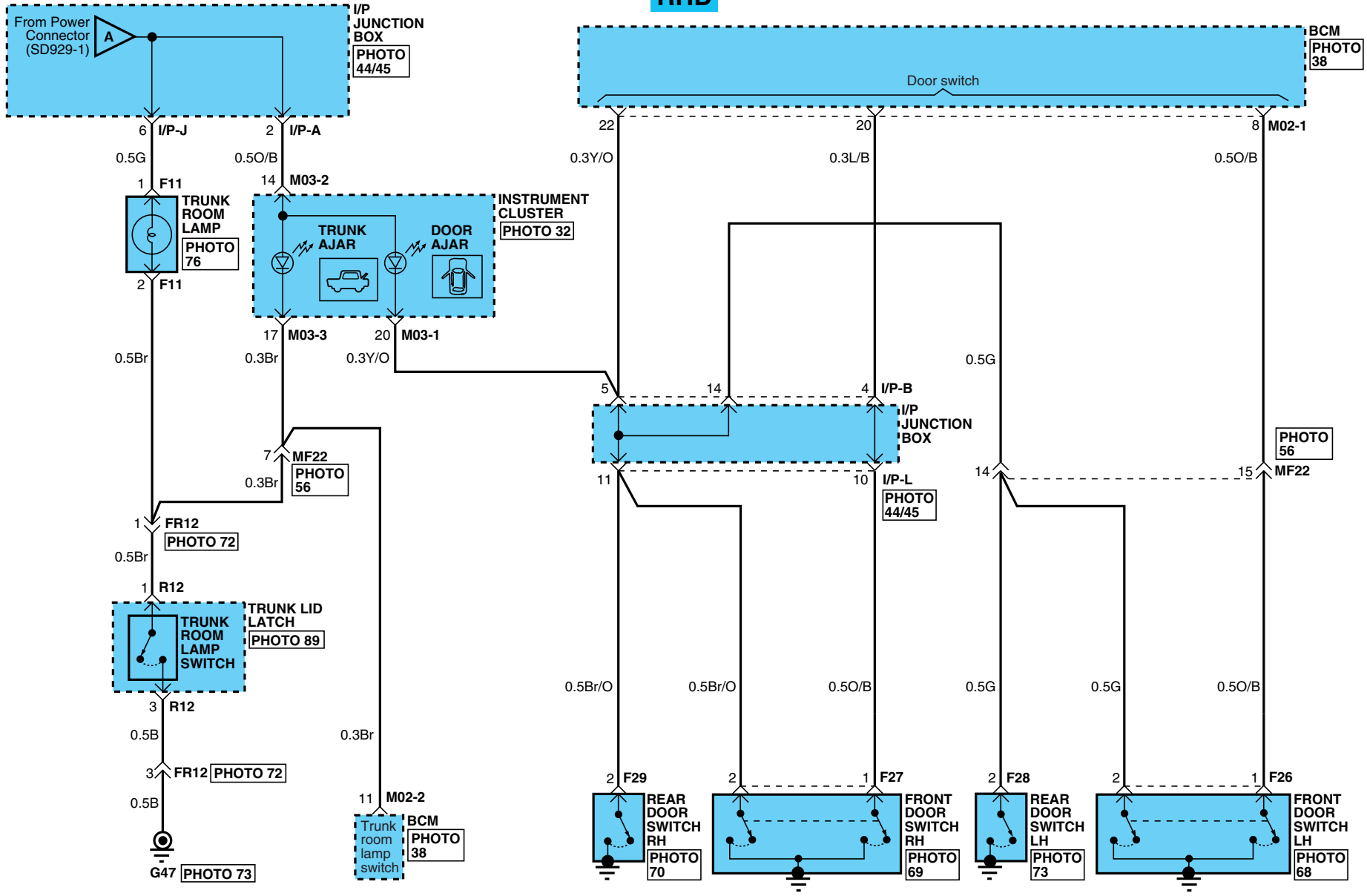

**COURTESY & TRUNK LAMPS**

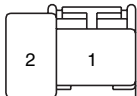
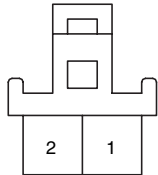
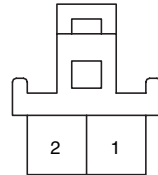
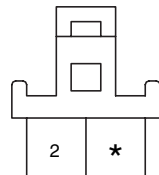
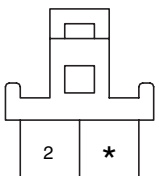
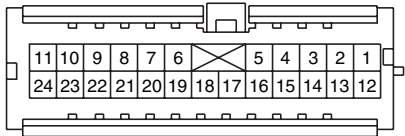
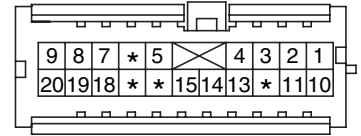
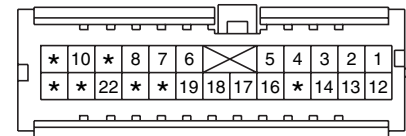
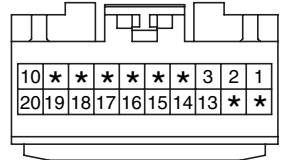
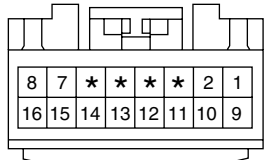
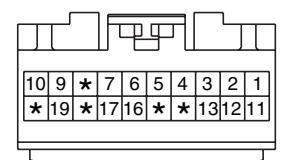
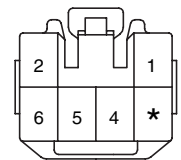
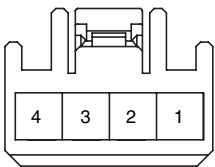
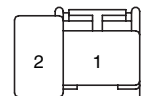
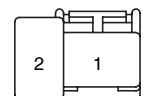
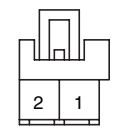
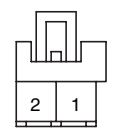
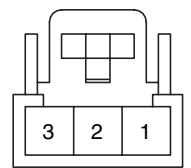
Courtesy & Trunk Lamps (4)			SD929-4
<p><b>F11</b></p>  <p>AMP_PLM2_02F_W_DL</p>	<p><b>F26</b></p>  <p>KET_070_02F_W</p>	<p><b>F27</b></p>  <p>KET_070_02F_W</p>	<p><b>F28</b></p>  <p>KET_070_02F_W</p>
<p><b>F29</b></p>  <p>KET_070_02F_W</p>	<p><b>M02-1</b></p>  <p>KET_040III_24F_W</p>	<p><b>M02-2</b></p>  <p>KET_040III_20F_W</p>	<p><b>M02-4</b></p>  <p>KET_040III_24F_Gr</p>
<p><b>M03-1</b></p>  <p>MLX_040III_20F_Gr</p>	<p><b>M03-2</b></p>  <p>MLX_040III_16F_Gr</p>	<p><b>M03-3</b></p>  <p>MLX_040III_20F_Gr</p>	<p><b>R04</b></p>  <p>KET_090II_06F_W</p>
<p><b>R05</b></p>  <p>AMP_090III_04F_W</p>	<p><b>R06</b></p>  <p>AMP_PLM2_02F_B_DL</p>	<p><b>R07</b></p>  <p>AMP_PLM2_02F_B_DL</p>	<p><b>R10</b></p>  <p>KUM_CDR_02F_W</p>
<p><b>R11</b></p>  <p>KUM_CDR_02F_W</p>	<p><b>R12</b></p>  <p>AMP_070_03F_W</p>	<p><b>BLANK</b></p>	<p><b>BLANK</b></p>

Indicators & Gauges (1)

SD940-1

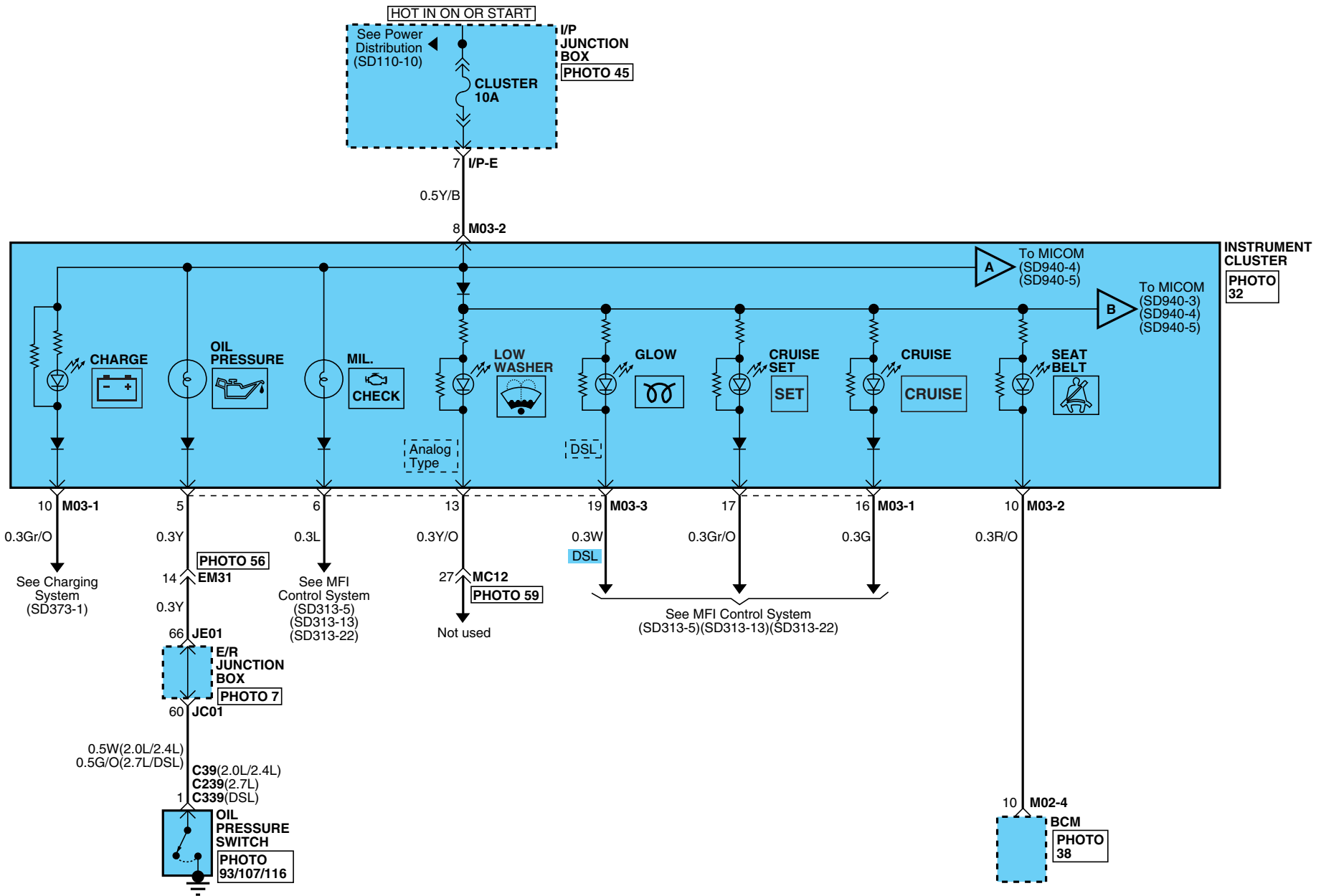



# INDICATORS & GAUGES

## Indicators & Gauges (2)

SD940-2

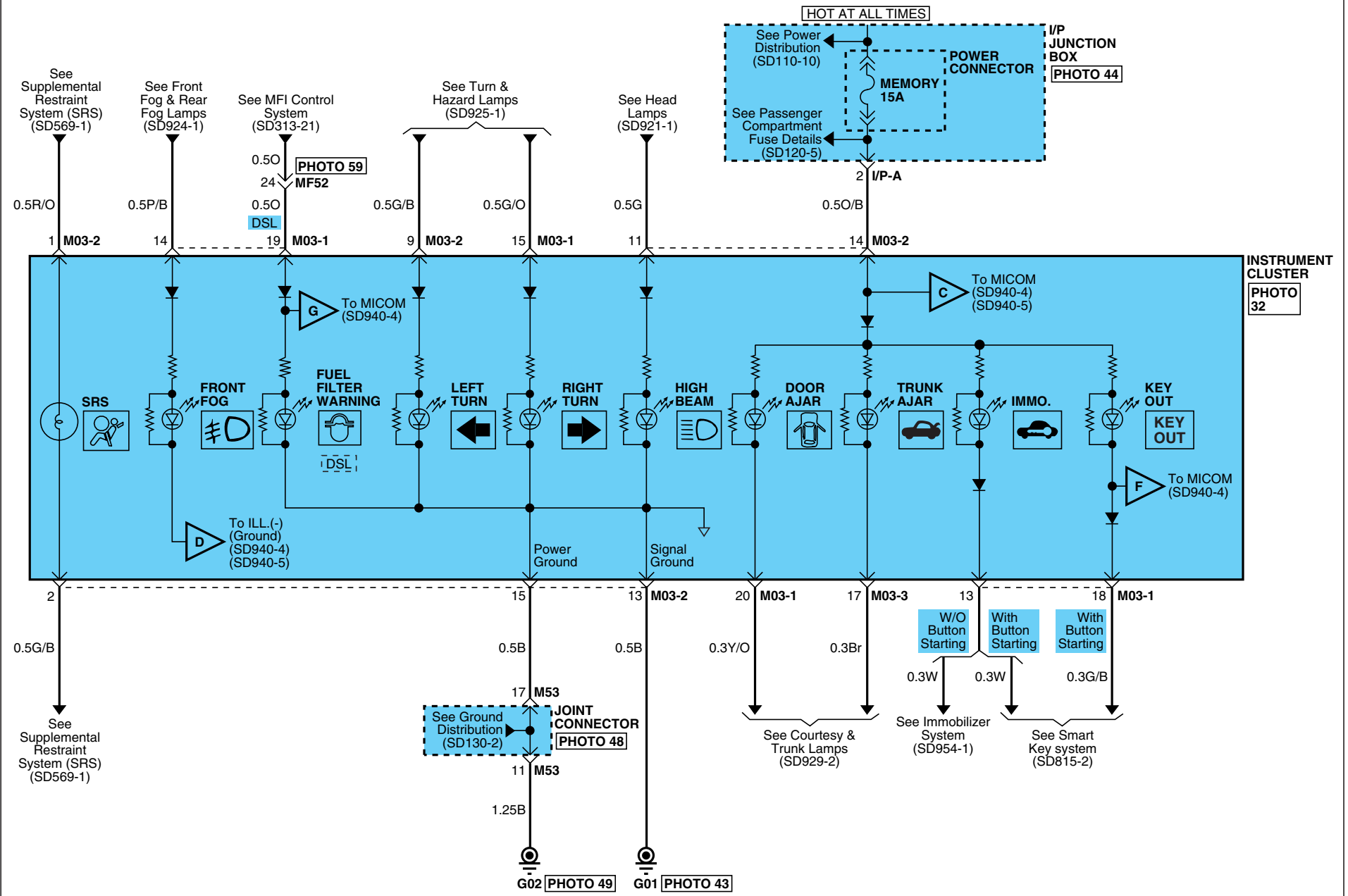



**ANALOG TYPE**

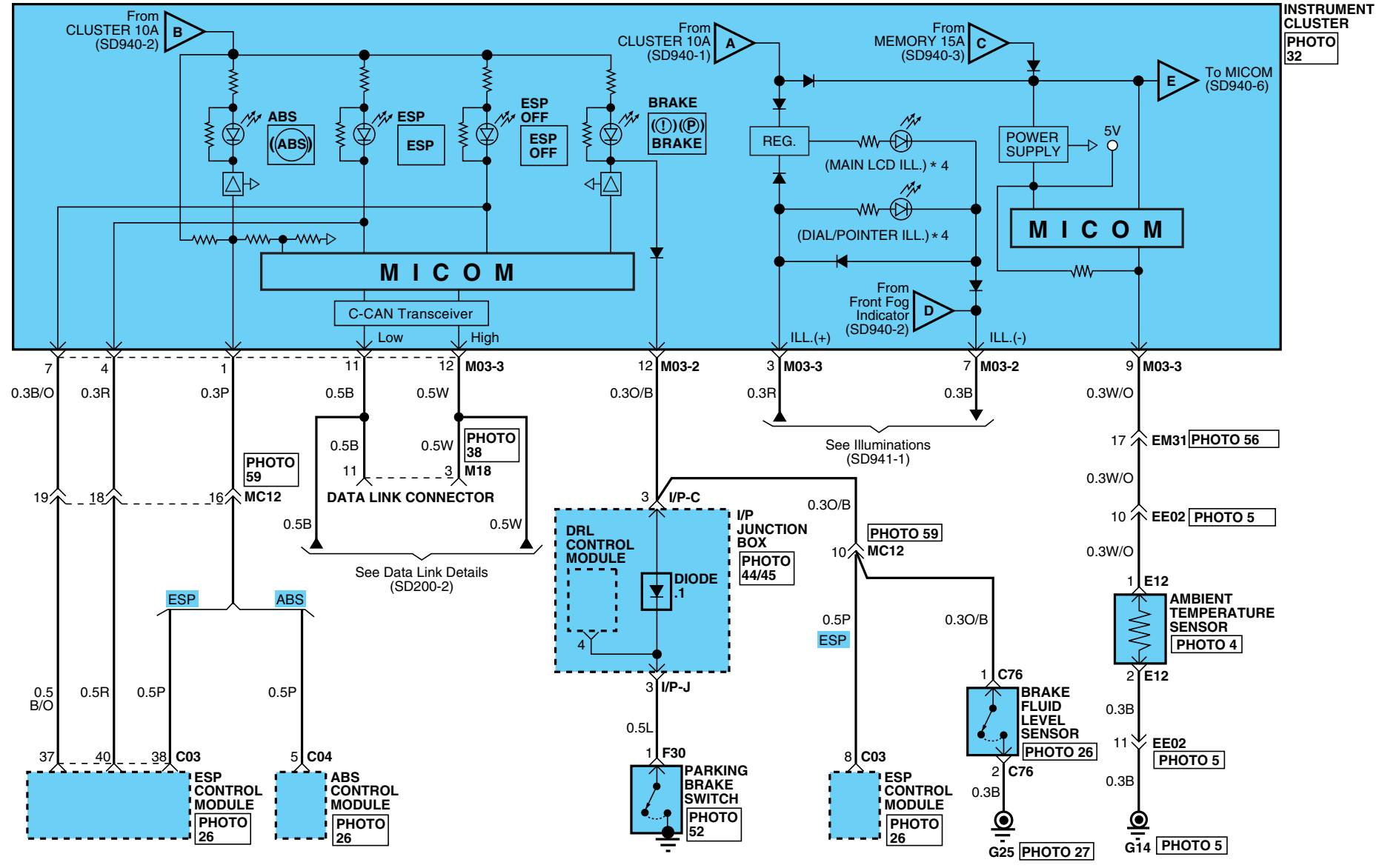

# INDICATORS & GAUGES



## Indicators & Gauges (5)

SD940-5

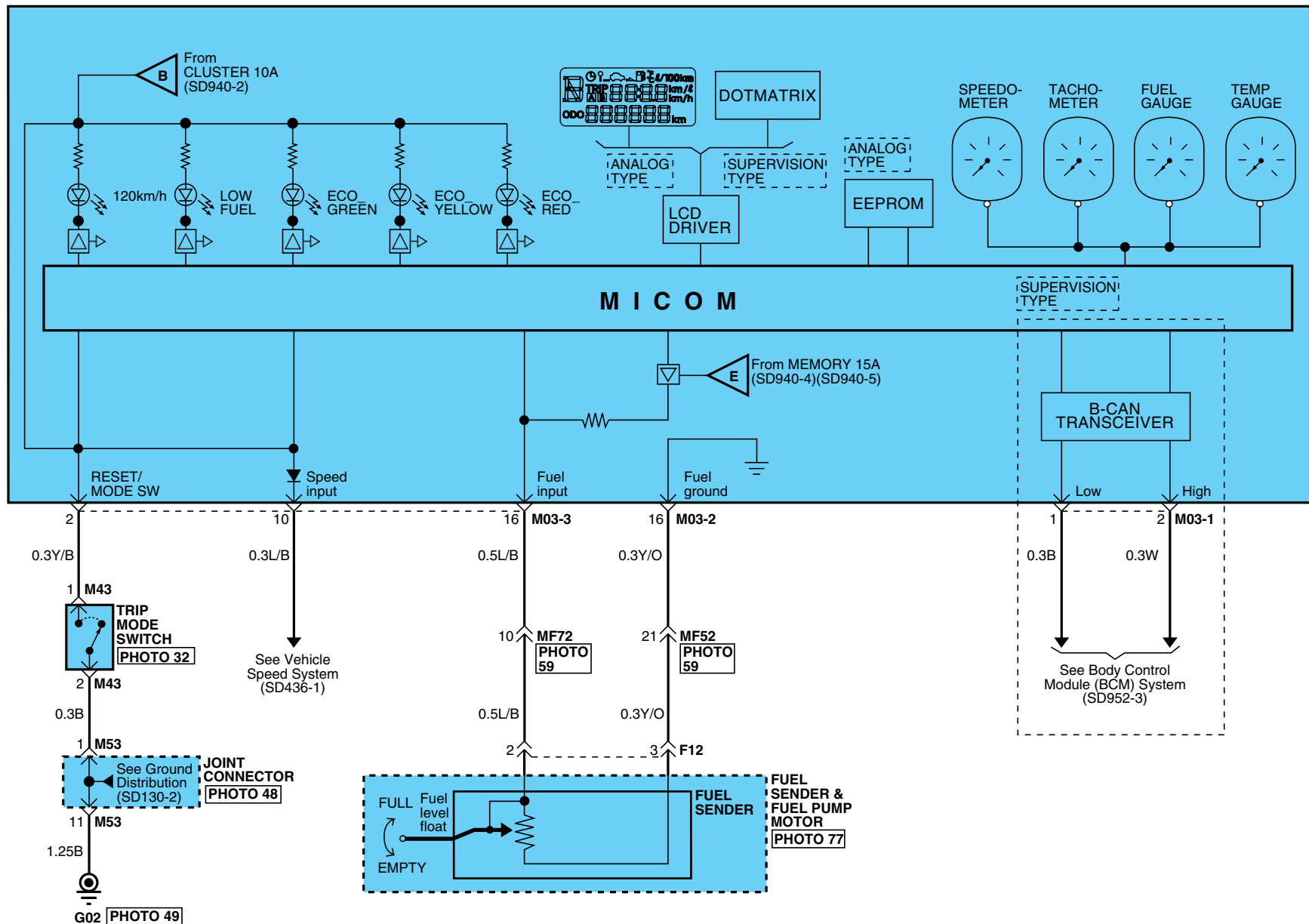
INSTRUMENT CLUSTER  
PHOTO 32

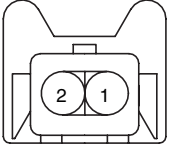

# INDICATORS & GAUGES

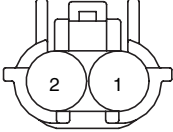
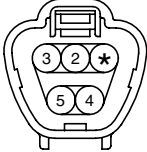
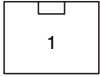
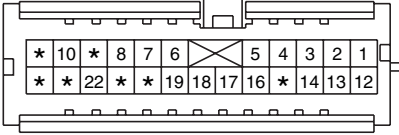
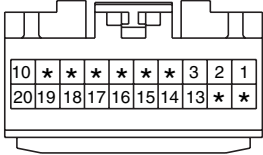
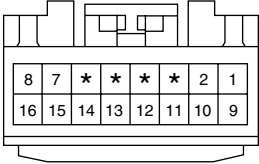
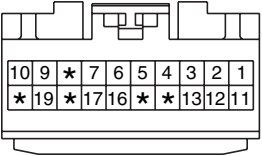
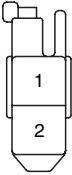
Indicators & Gauges (6)			SD940-6
<p><b>C76</b></p>  <p>AMP_JPT_02F_B</p>	<p><b>C39/C239/C339</b></p>  <p>KUM_NMWP_01F_B</p>	<p><b>E12</b></p>  <p>KET_SWP_02F_B</p>	<p><b>F12</b></p>  <p>KET_090IWP_05F_Gr_2</p>
<p><b>F30</b></p>  <p>AMP_PLM1_01F_B</p>	<p><b>M02-4</b></p>  <p>KET_040III_24F_Gr</p>	<p><b>M03-1</b></p>  <p>MLX_040III_20F_Gr</p>	<p><b>M03-2</b></p>  <p>MLX_040III_16F_Gr</p>
<p><b>M03-3</b></p>  <p>MLX_040III_20F_Gr</p>	<p><b>M43</b></p>  <p>KET_090II_02F_W_SPK</p>	<p><b>BLANK</b></p>	<p><b>BLANK</b></p>





# ILLUMINATIONS

## Illuminations (3)

SD941-3

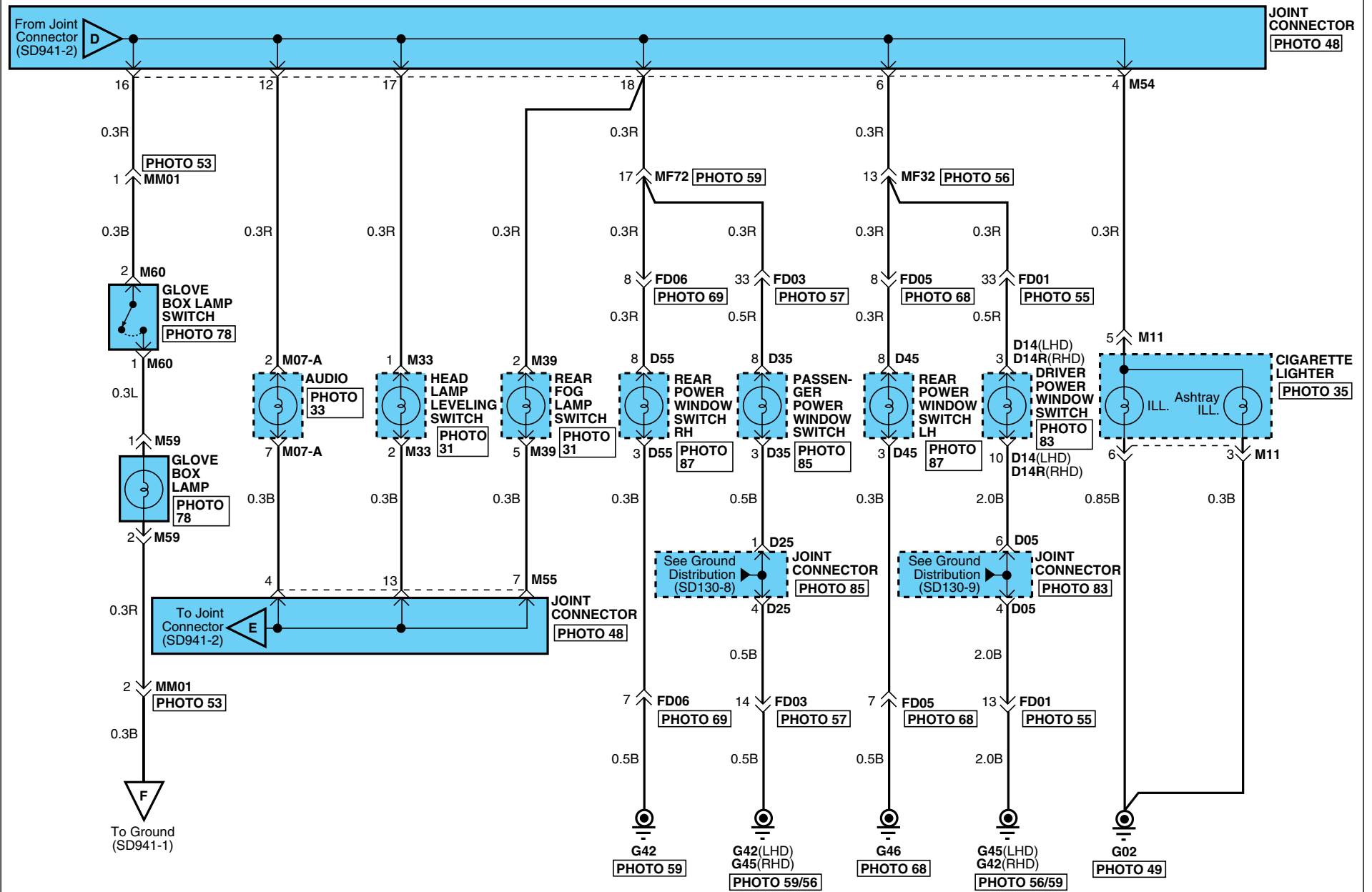





# ILLUMINATIONS

Illuminations (4)			SD941-4
<p><b>C48</b></p> <p>KET_090II_11F_W</p>	<p><b>D14/D14R</b></p> <p>KET_090II_14F_B</p>	<p><b>D35</b></p> <p>KET_090II_08F_B</p>	<p><b>D45</b></p> <p>KET_090II_08F_W</p>
<p><b>D55</b></p> <p>KET_090II_08F_W</p>	<p><b>M02-2</b></p> <p>KET_040III_20F_W</p>	<p><b>M02-4</b></p> <p>KET_040III_24F_Gr</p>	<p><b>M03-2</b></p> <p>MLX_040III_16F_Gr</p>
<p><b>M03-3</b></p> <p>MLX_040III_20F_Gr</p>	<p><b>M07-A</b></p> <p>AMP_JT_08F_Gr</p>	<p><b>M08-1</b></p> <p>AMP_0407_26F_W_HD</p>	<p><b>M09-1</b></p> <p>KET_0407_26F_W</p>
<p><b>M11</b></p> <p>AMP_070_06F_W</p>	<p><b>M12</b></p> <p>KUM_AR_08F_W</p>	<p><b>M15</b></p> <p>MLX_025_10F_B</p>	<p><b>M22</b></p> <p>KUM_CDR_07F_B</p>
<p><b>M30</b></p> <p>KET_090II_06F_G</p>	<p><b>M31</b></p> <p>KET_090II_06F_R</p>	<p><b>M32</b></p> <p>KET_090II_10F_W</p>	<p><b>M33</b></p> <p>KUM_CDR_05F_W</p>

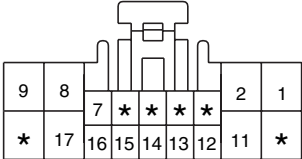
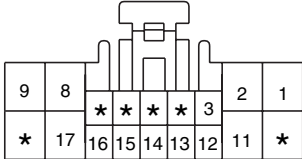
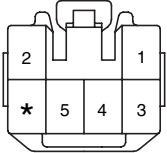
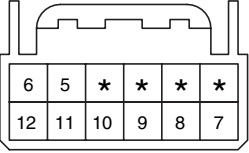
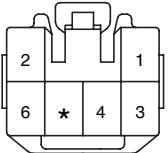
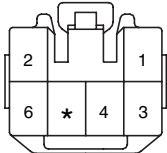
# ILLUMINATIONS

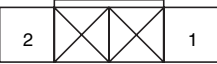
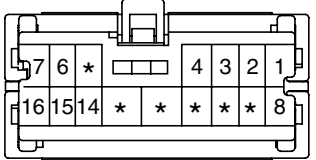
Illuminations (5)			SD941-5
<p style="text-align: center;"><b>M37</b></p>  <p style="text-align: center;">KET_0509_18F_W</p>	<p style="text-align: center;"><b>M37R</b></p>  <p style="text-align: center;">KET_0509_18F_W</p>	<p style="text-align: center;"><b>M39</b></p>  <p style="text-align: center;">KET_090II_06F_L</p>	<p style="text-align: center;"><b>M40</b></p>  <p style="text-align: center;">AMP_025_12F_W</p>
<p style="text-align: center;"><b>M41</b></p>  <p style="text-align: center;">KET_090II_06F_B</p>	<p style="text-align: center;"><b>M42</b></p>  <p style="text-align: center;">KET_090II_06F_W</p>	<p style="text-align: center;"><b>M59</b></p>  <p style="text-align: center;">18324-25013</p>	<p style="text-align: center;"><b>M60</b></p>  <p style="text-align: center;">KET_187_02F_W</p>
<p style="text-align: center;"><b>M69</b></p>  <p style="text-align: center;">KET_040III</p>	<p style="text-align: center;"><b>BLANK</b></p>	<p style="text-align: center;"><b>BLANK</b></p>	<p style="text-align: center;"><b>BLANK</b></p>

**ILLUMINATIONS**

**Illuminations (6)**

**SD941-6**

**MEMO**

# CLOCK & CIGARETTE LIGHTER (POWER OUTLET)

E5DBEEA5

## Clock & Cigarette Lighter (Power Outlet) (1)

SD945-1

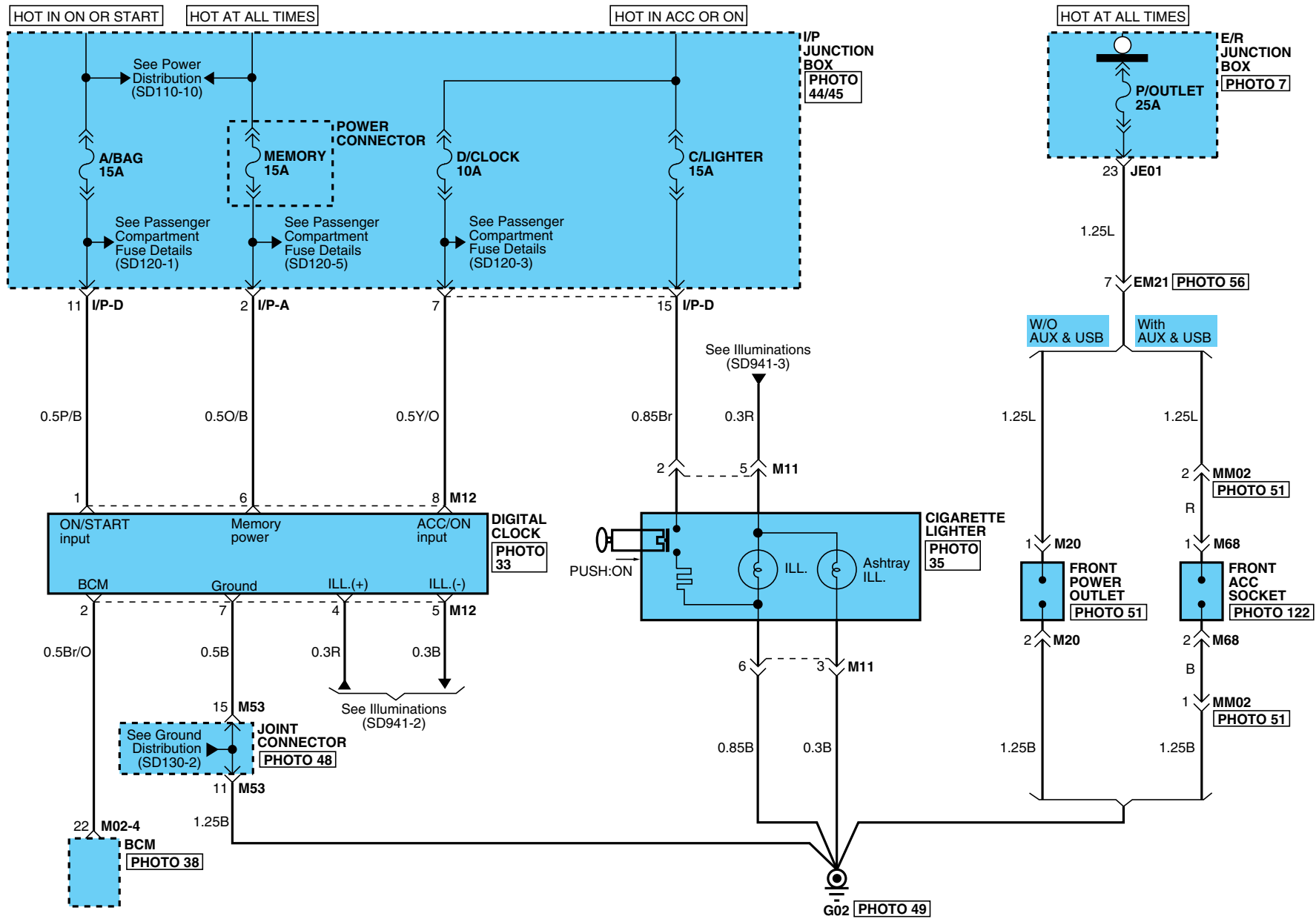

# CLOCK & CIGARETTE LIGHTER (POWER OUTLET)

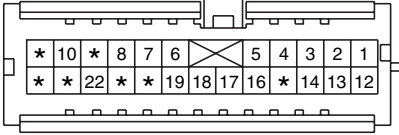
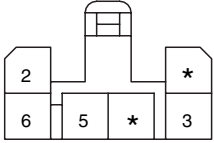
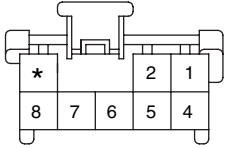
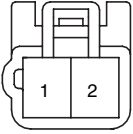
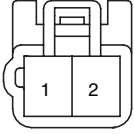
Clock & Cigarette Lighter (Power Outlet) (2)			SD945-2
<p style="text-align: center;"><b>M02-4</b></p>  <p style="text-align: right; font-size: small;">KET_040III_24F_Gr</p>	<p style="text-align: center;"><b>M11</b></p>  <p style="text-align: right; font-size: small;">AMP_070_06F_W</p>	<p style="text-align: center;"><b>M12</b></p>  <p style="text-align: right; font-size: small;">KUM_AR_08F_W</p>	<p style="text-align: center;"><b>M20</b></p>  <p style="text-align: right; font-size: small;">KET_090II_02M_B_L</p>
<p style="text-align: center;"><b>M68</b></p>  <p style="text-align: right; font-size: small;">KET_090II_02M</p>	<p><b>BLANK</b></p>	<p><b>BLANK</b></p>	<p><b>BLANK</b></p>



# AUTO LIGHTS

## Auto Lights (2)

SD951-2

**C70**



KUM\_NMWP\_06F\_B

**E07**



KUM\_NMWP\_06F\_B

**M02-1**

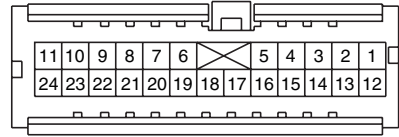

KET\_040III\_24F\_W

**M02-2**

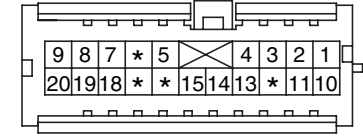

KET\_040III\_20F\_W

**M02-3**

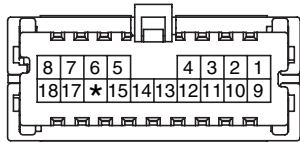

KET\_040III\_18F\_W

**M02-4**

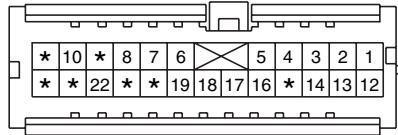

KET\_040III\_24F\_Gr

**M03-2**

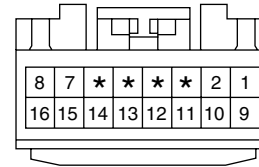

MLX\_040III\_16F\_Gr

**M25**

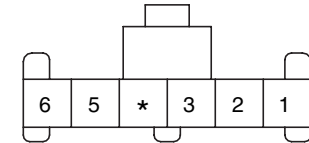

KET\_91A\_06F\_W

**M37**

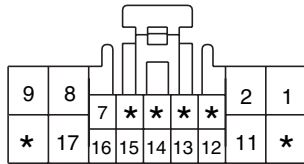

KET\_0509\_18F\_W

**M37R**

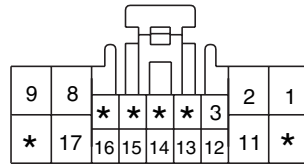

KET\_0509\_18F\_W

**BLANK**

**BLANK**

**Body Control Module (BCM) System (1)**

**SD952-1**

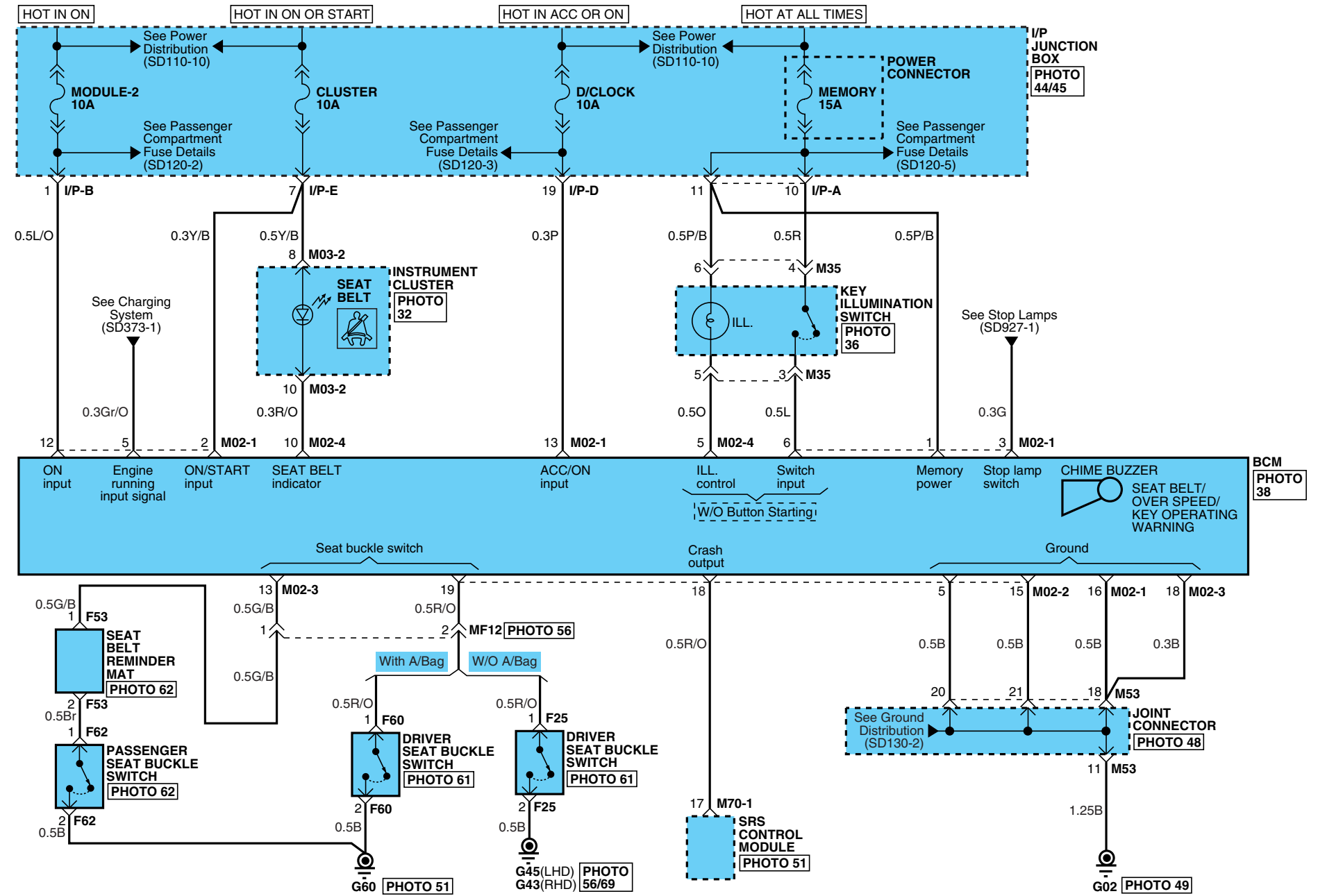



# BODY CONTROL MODULE (BCM) SYSTEM

## Body Control Module (BCM) System (2)

SD952-2

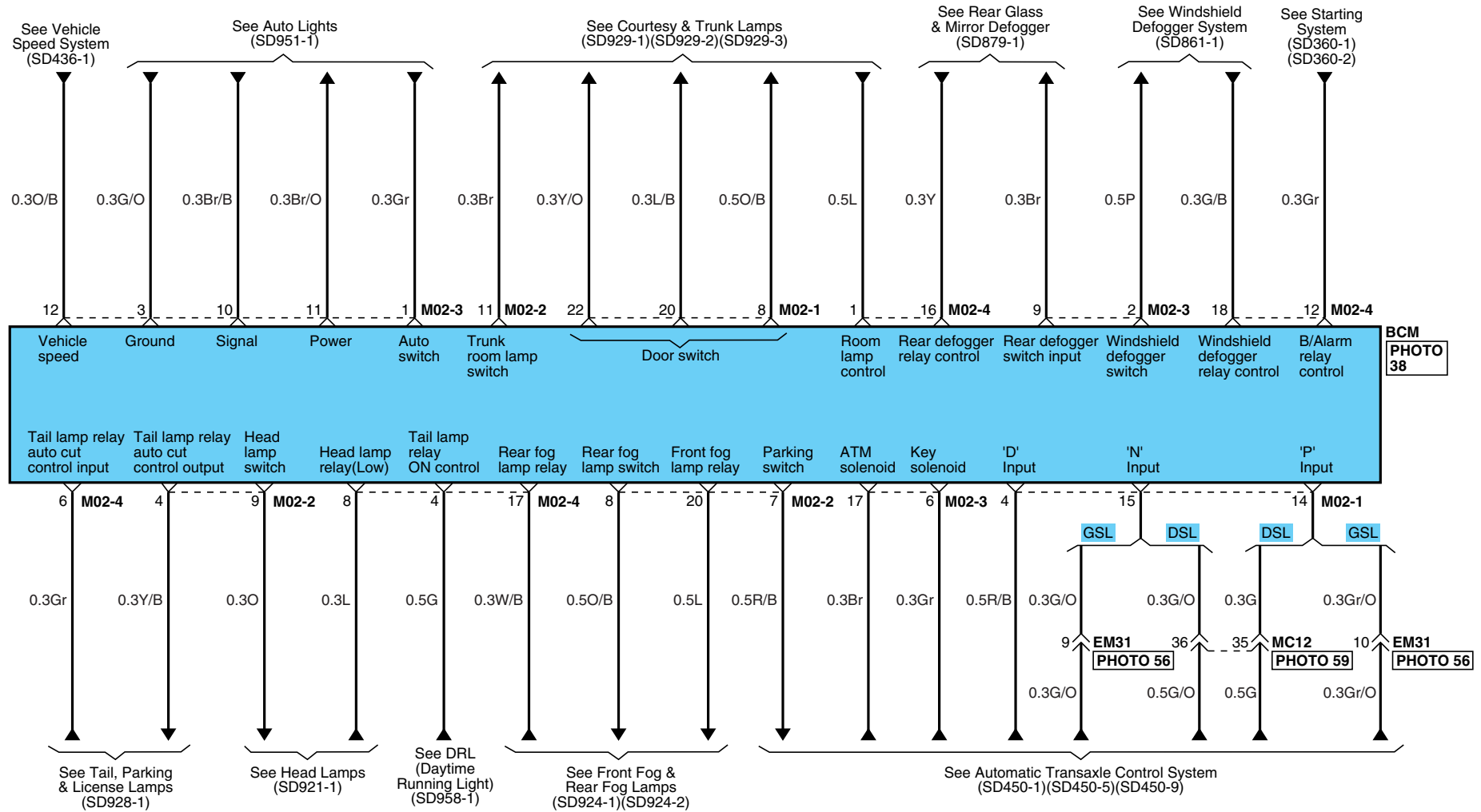

# BODY CONTROL MODULE (BCM) SYSTEM

## Body Control Module (BCM) System (3)

SD952-3

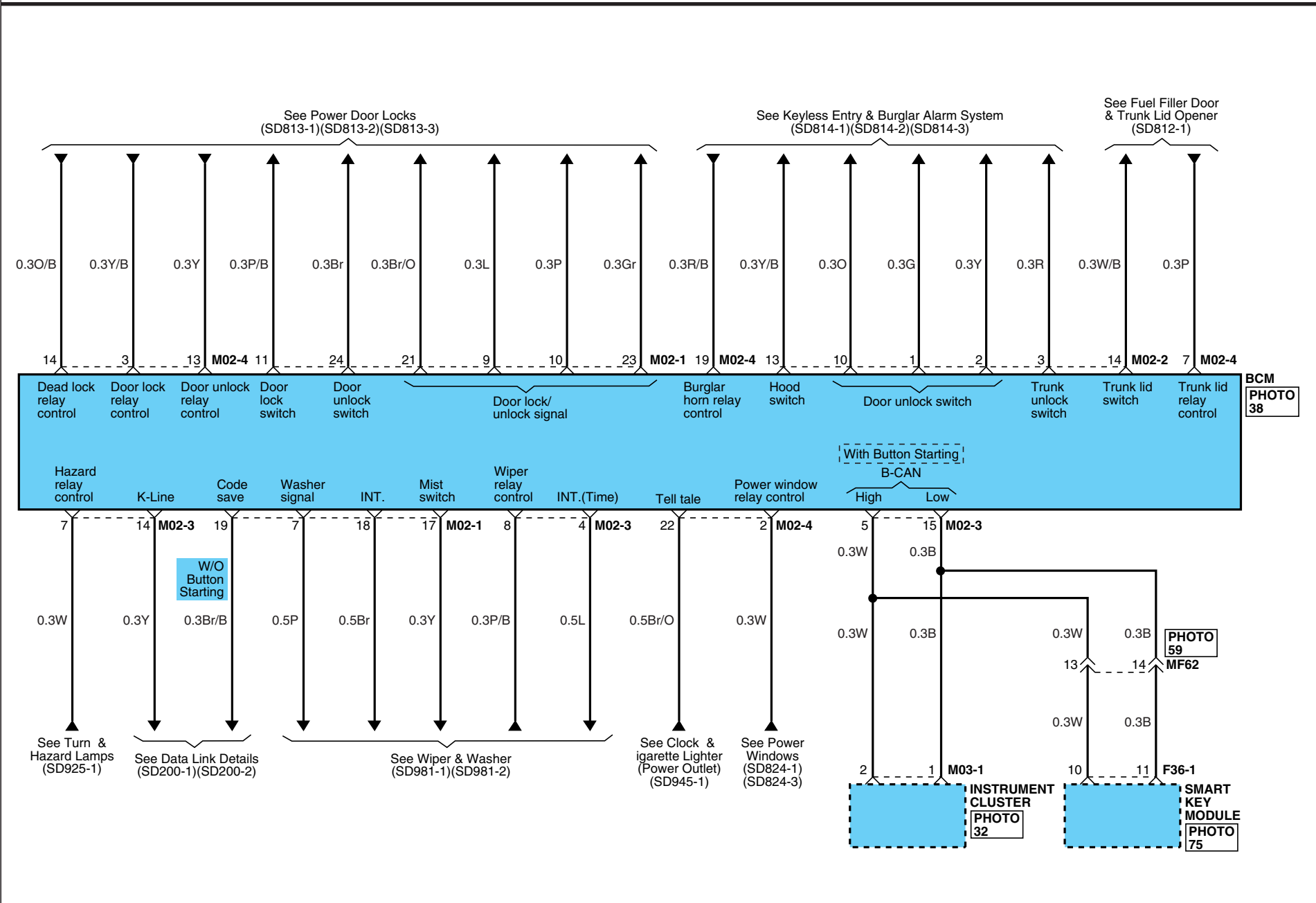

# BODY CONTROL MODULE (BCM) SYSTEM

## Body Control Module (BCM) System (4)

SD952-4

**F25**

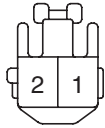

KET\_090III\_02F\_W\_L

**F36-1**

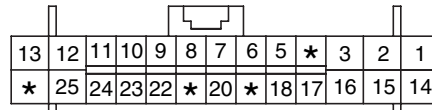

AMP\_0407\_26F\_W\_HD

**F53**

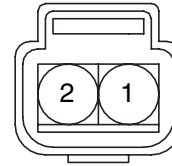

AMP\_MQSWP\_02F\_B

**F60/F62**

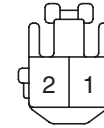

KET\_090III\_02F\_W\_L

**M02-1**

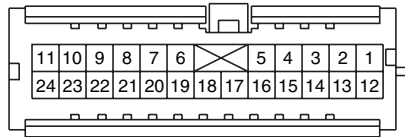

KET\_040III\_24F\_W

**M02-2**

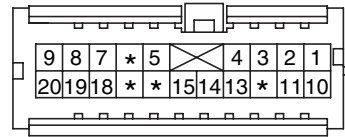

KET\_040III\_20F\_W

**M02-3**

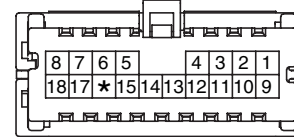

KET\_040III\_18F\_W

**M02-4**

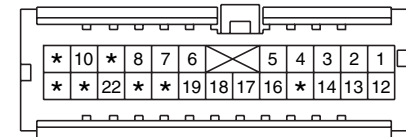

KET\_040III\_24F\_Gr

**M03-1**

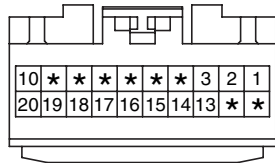

MLX\_040III\_20F\_Gr

**M03-2**

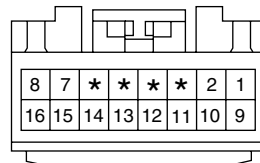

MLX\_040III\_16F\_Gr

**M07-C1**

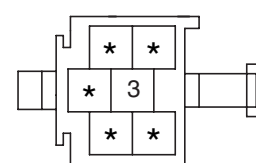

AMP\_MTII\_06F\_Y

**M35**

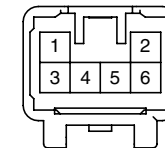

KET\_090II\_06M\_W

**M70-1**



AMP\_ACU\_24F

**BLANK**

**BLANK**

**BLANK**

Power Distribution Module (PDM) (1)

SD952-5

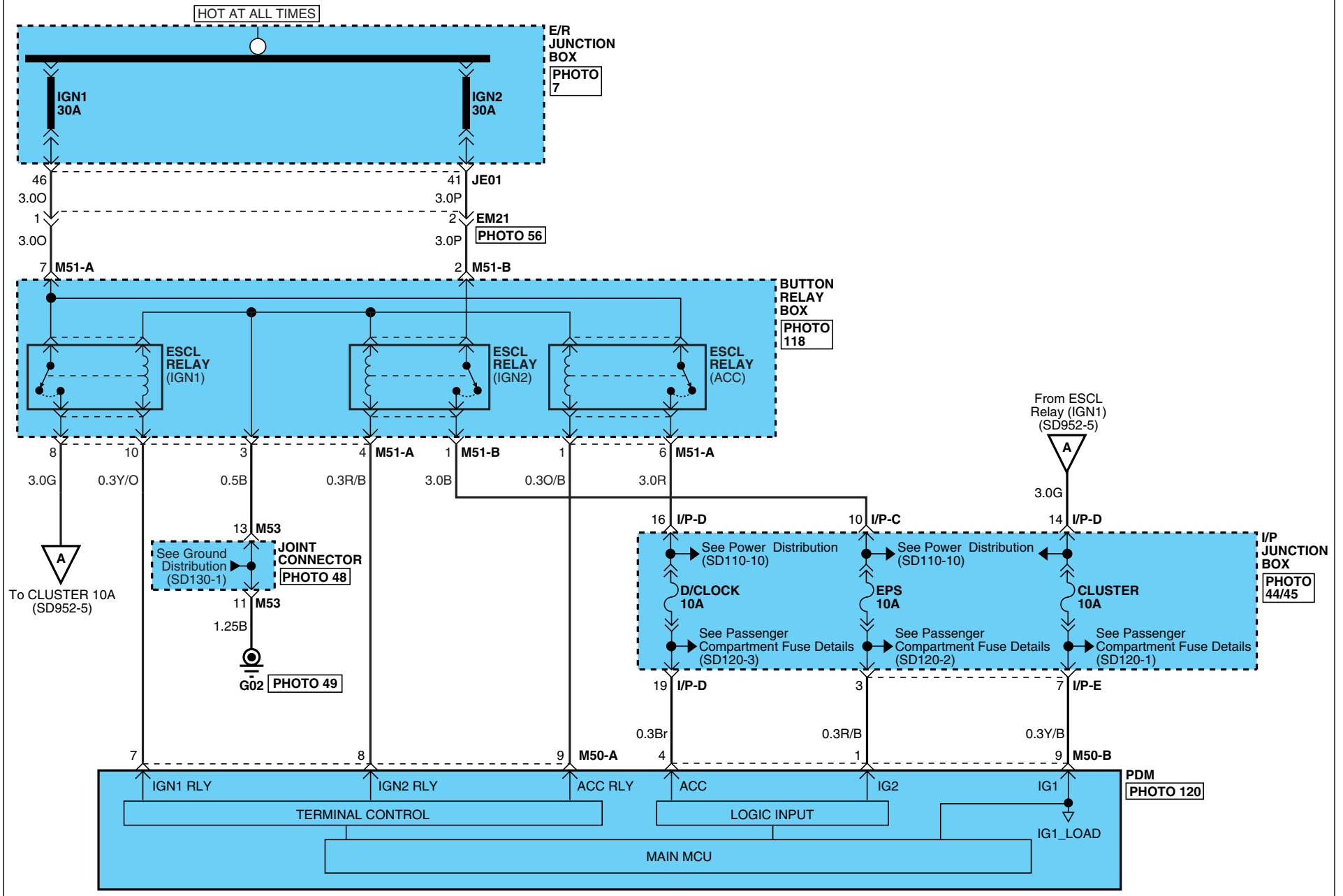

# POWER DISTRIBUTION MODULE (PDM)

## Power Distribution Module (PDM) (2)

SD952-6

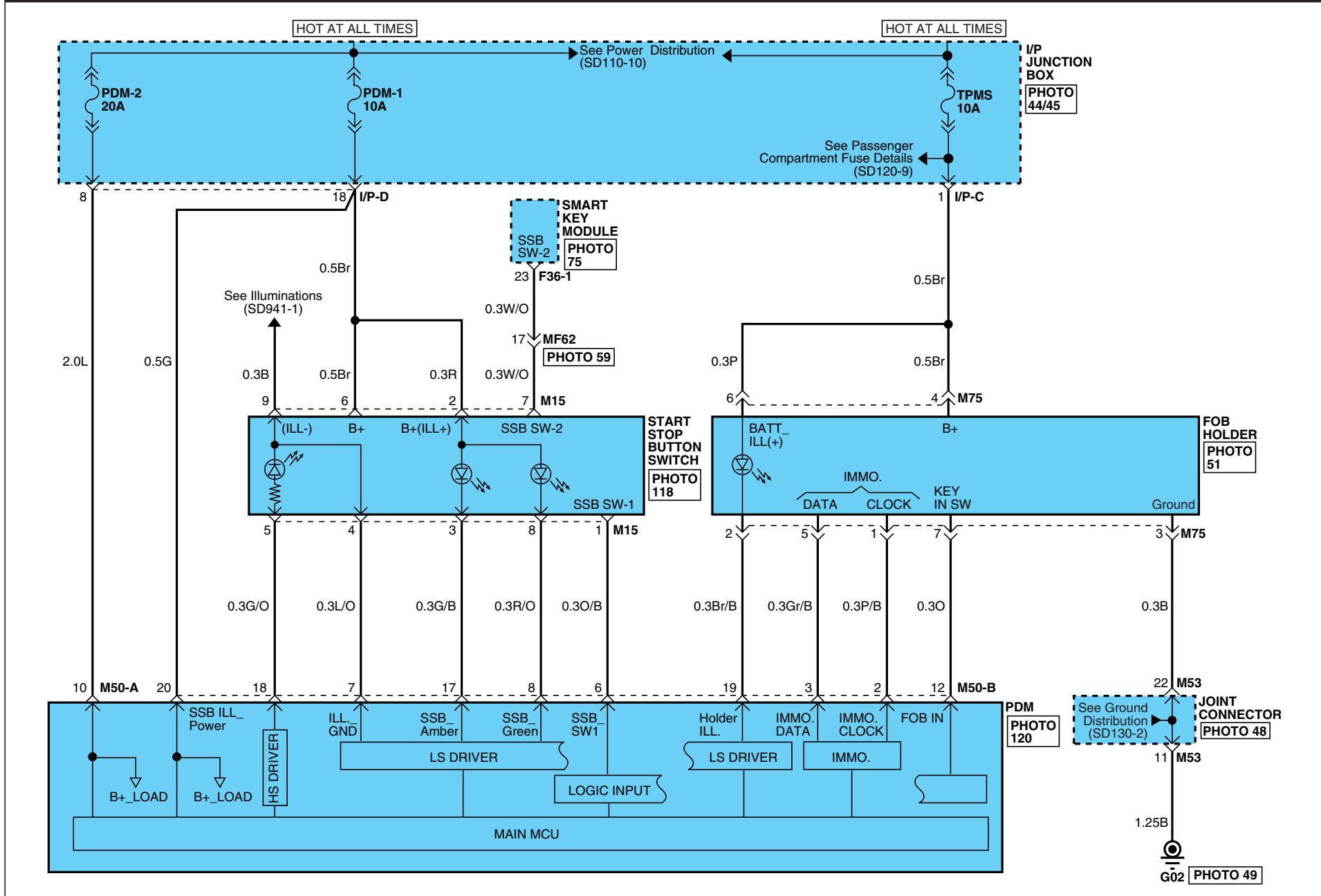

# POWER DISTRIBUTION MODULE (PDM)

## Power Distribution Module (PDM) (3)

SD952-7

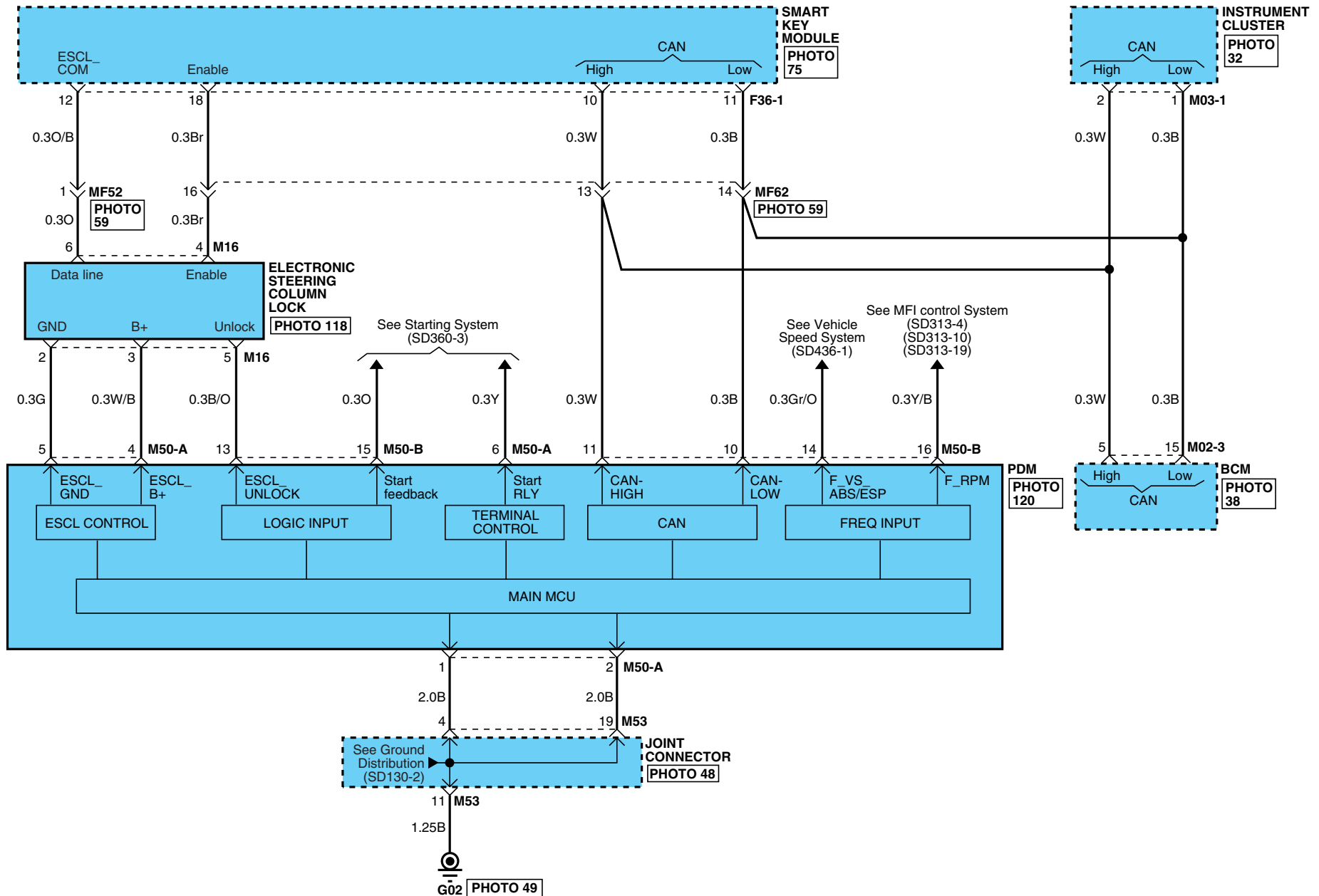

# POWER DISTRIBUTION MODULE (PDM)

## Power Distribution Module (PDM) (4)

SD952-8

**F36-1**

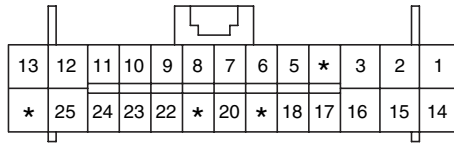

AMP\_0407\_26F\_W\_HD

**M02-3**

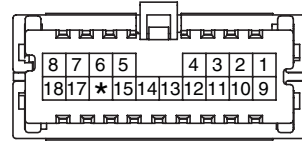

KET\_040III\_18F\_W

**M03-1**

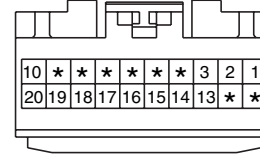

MLX\_040III\_20F\_Gr

**M15**

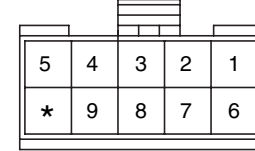

MLX\_025\_10F\_B

**M16**

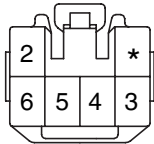

KET\_090II\_06F

**M50-A**

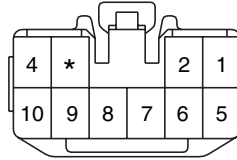

KET\_090II\_10F

**M50-B**

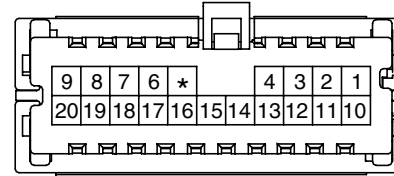

KET\_040III\_20F

**M51-A**

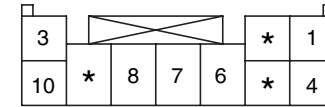

AMP\_0925\_10F\_W

**M51-B**

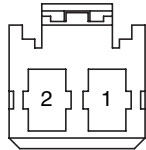

AMP\_025JPT\_02F\_B

**M75**

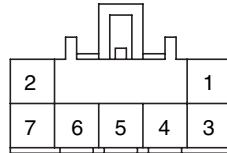

KUM\_CDR\_07F

**BLANK**

**BLANK**

Immobilizer System (1)

SD954-1

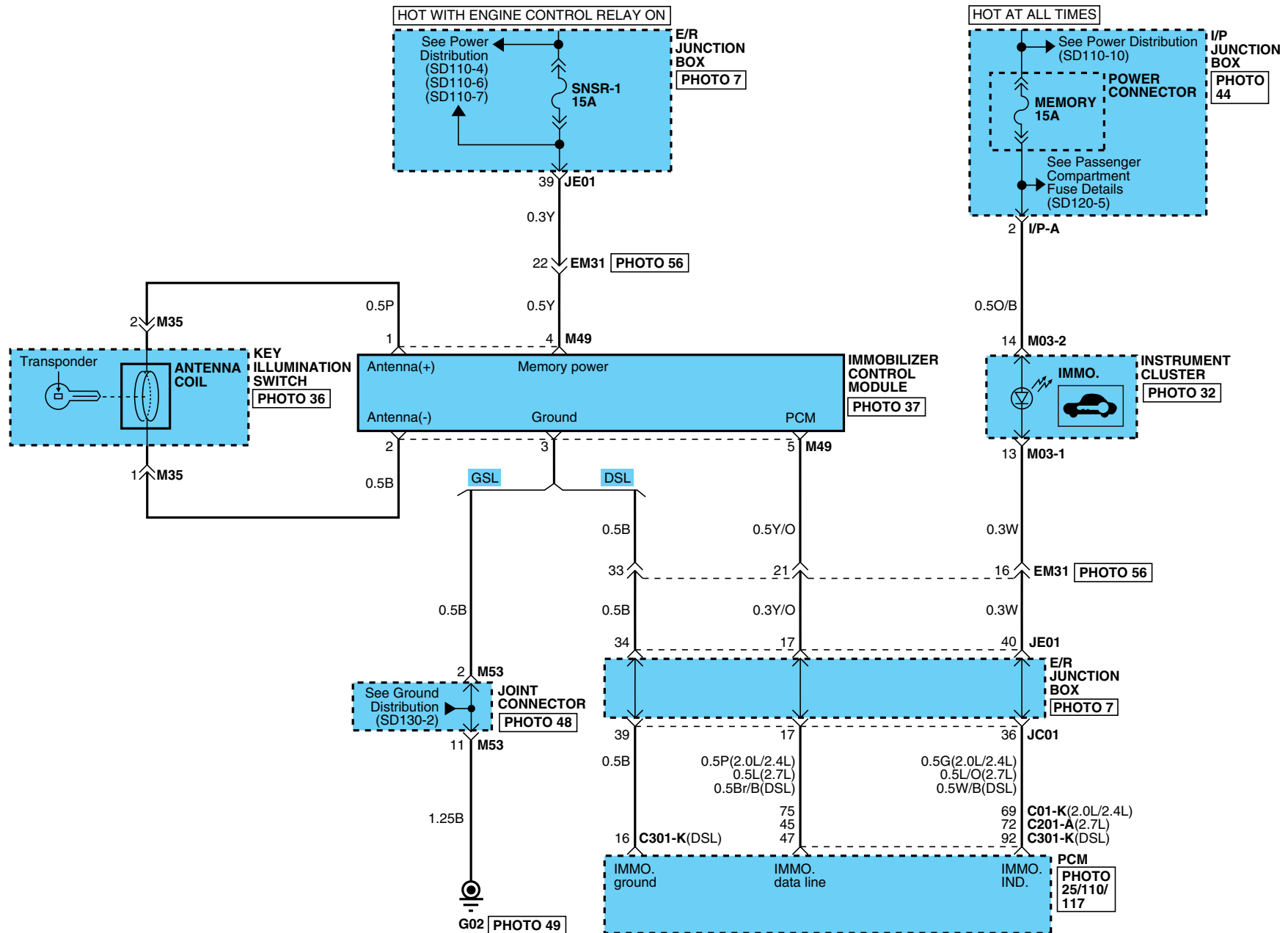



# IMMOBILIZER SYSTEM

## Immobilizer System (2)

SD954-2

**C01-K**

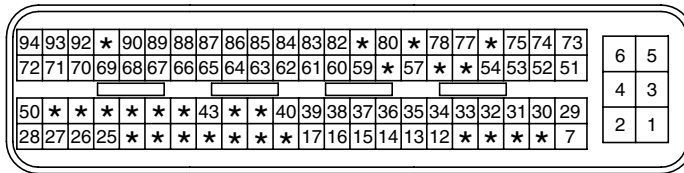

AMP\_PCU\_94F\_B\_SIE

**C301-K**

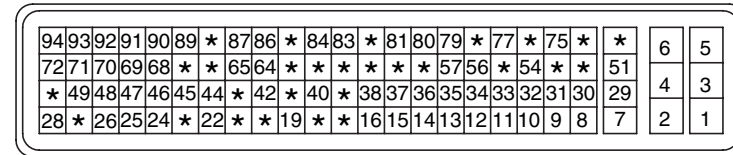

AMP\_PCU\_94F\_B\_SIE

**C201-A**

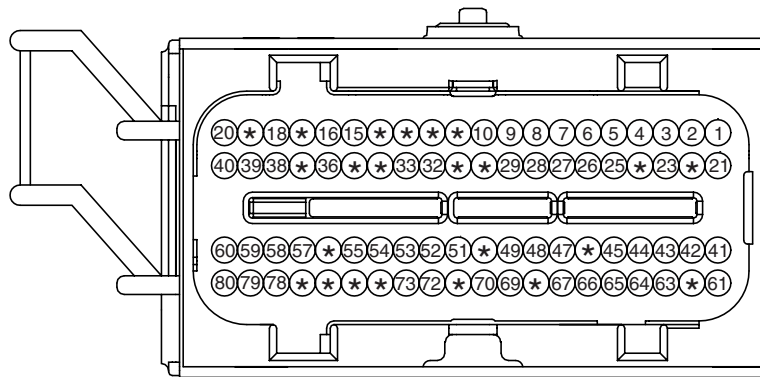

PKD\_ECU\_80F\_GR\_1

**M03-1**

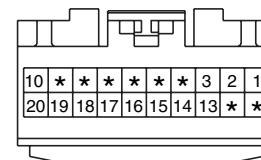

MLX\_040III\_20F\_Gr

**M03-2**

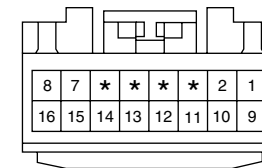

MLX\_040III\_16F\_Gr

**M35**

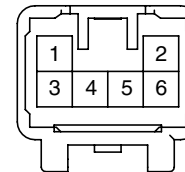

KET\_090II\_06M\_W

**M49**

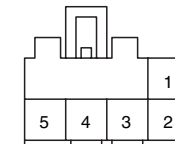

KUM\_CDR\_05F\_W

Rear Parking Assist System (1)

SD957-1

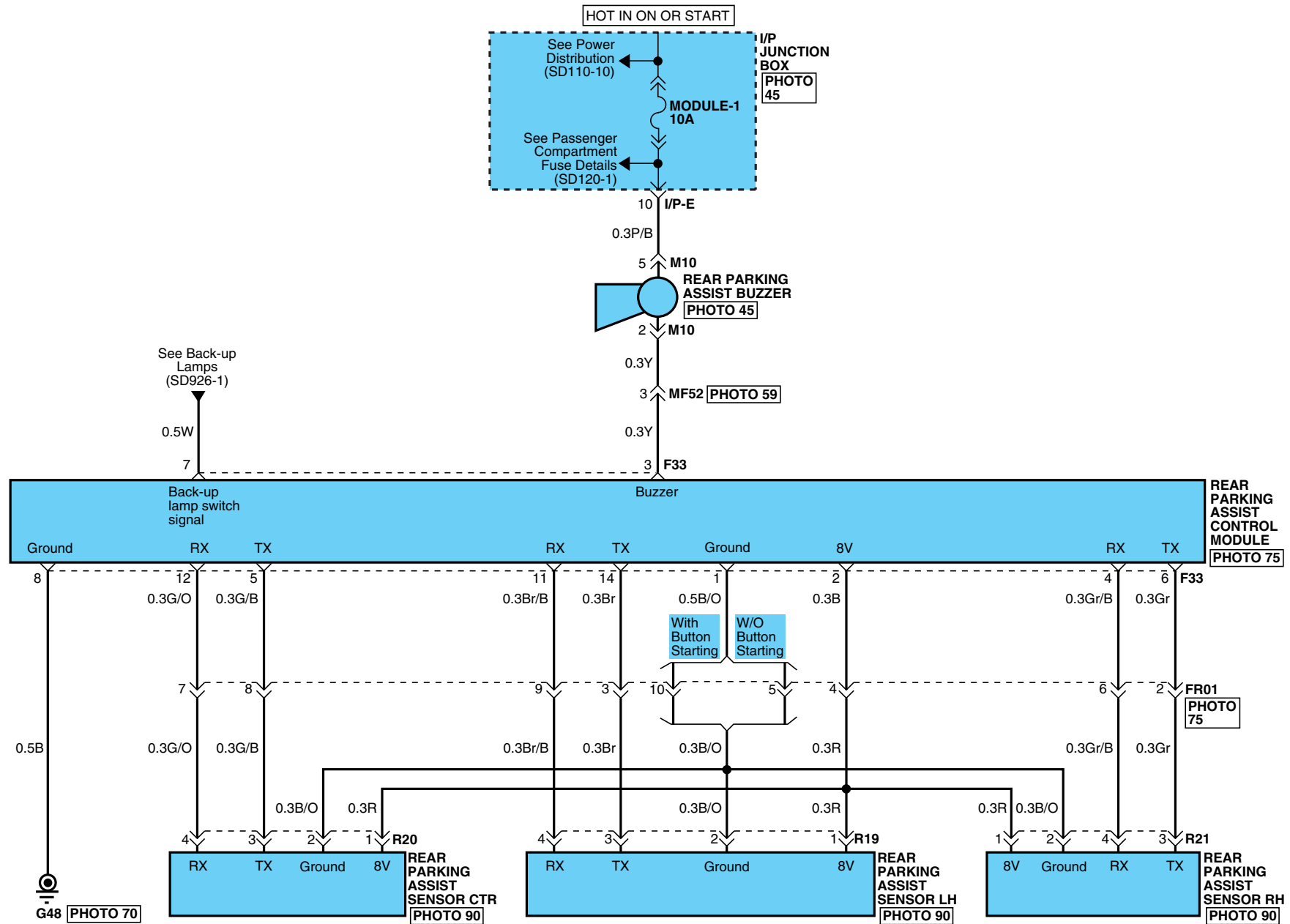

# REAR PARKING ASSIST SYSTEM

## Rear Parking Assist System (2)

SD957-2

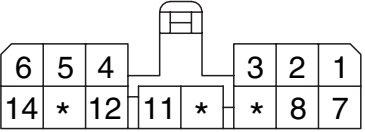
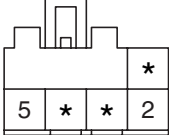
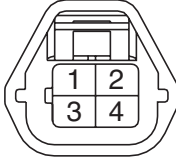
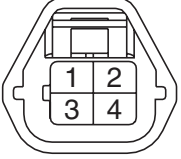
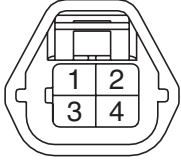
<p style="text-align: center;"><b>F33</b></p>  <p style="text-align: right; font-size: small;">AMP_070_14F_W</p>	<p style="text-align: center;"><b>M10</b></p>  <p style="text-align: right; font-size: small;">KUM_CDR_05F_W</p>	<p style="text-align: center;"><b>R19</b></p>  <p style="text-align: right; font-size: small;">MG641238</p>	<p style="text-align: center;"><b>R20</b></p>  <p style="text-align: right; font-size: small;">MG641238</p>
<p style="text-align: center;"><b>R21</b></p>  <p style="text-align: right; font-size: small;">MG641238</p>	<p><b>BLANK</b></p>	<p><b>BLANK</b></p>	<p><b>BLANK</b></p>

DRL (Daytime Running Light) (1)

SD958-1

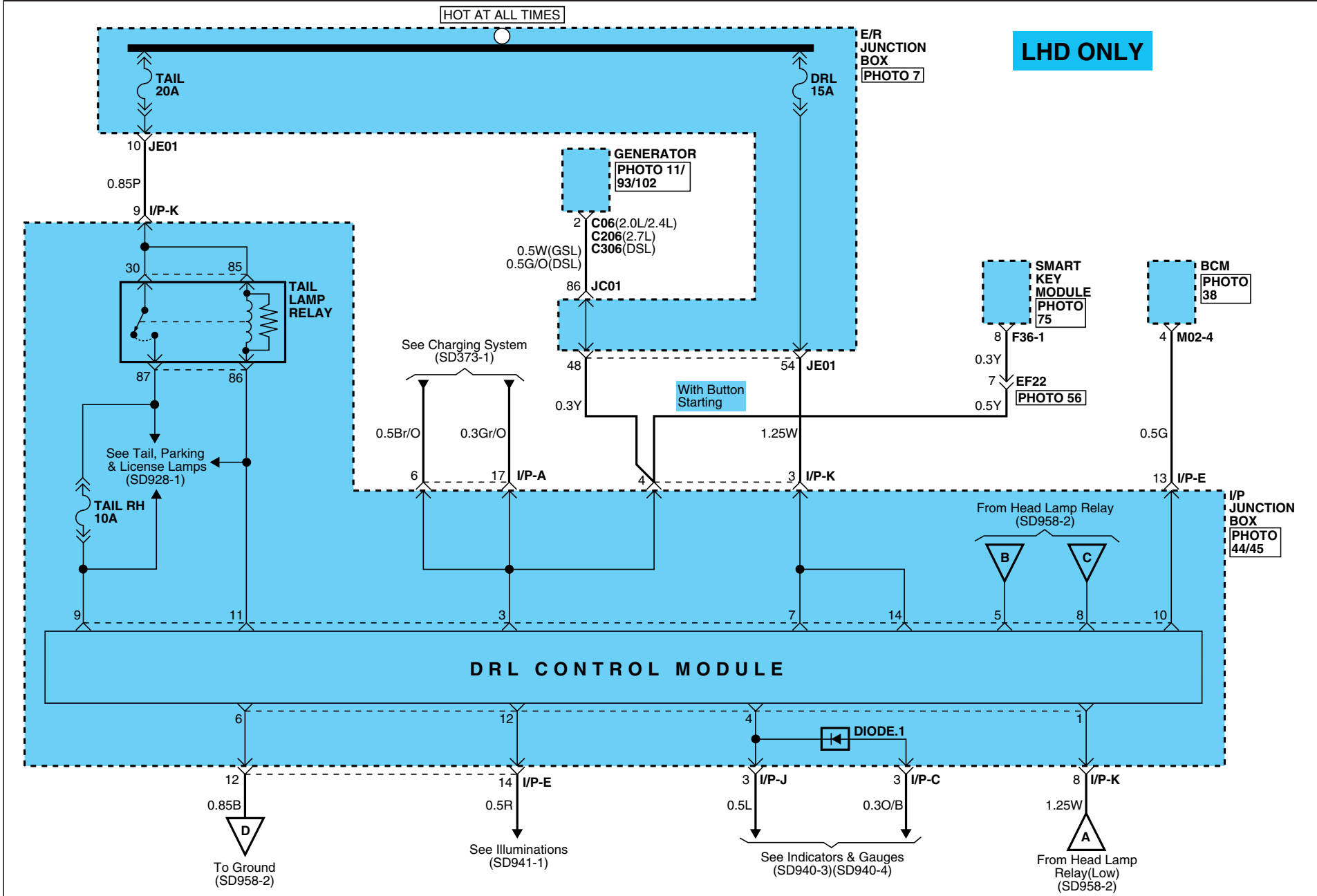

# DRL (DAYTIME RUNNING LIGHT)

## DRL (Daytime Running Light) (2)

SD958-2

**LHD ONLY**

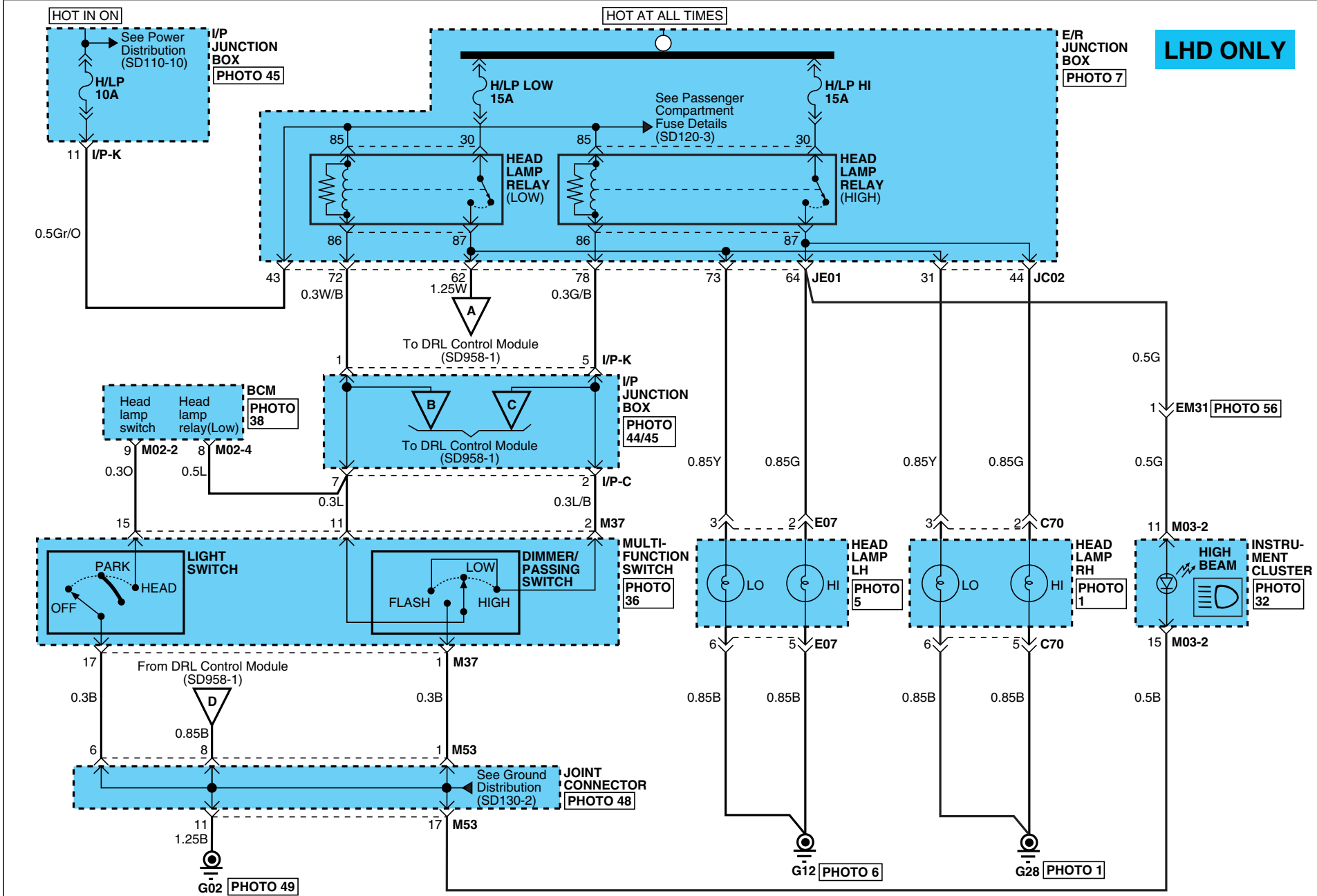

# DRL (DAYTIME RUNNING LIGHT)

## DRL (Daytime Running Light) (3)

SD958-3

**C06/C206**

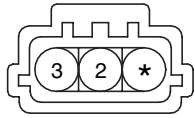

SUM\_ALTWP\_03F\_B

**C70**

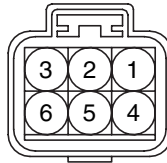

KUM\_NMWP\_06F\_B

**C306**

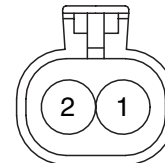

KET\_58X\_02F\_B

**E07**

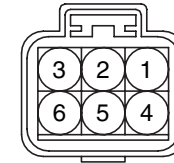

KUM\_NMWP\_06F\_B

**F36-1**

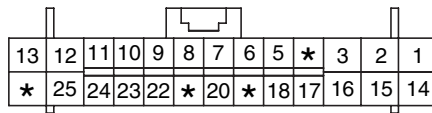

AMP\_0407\_26F\_W\_HD

**M02-2**

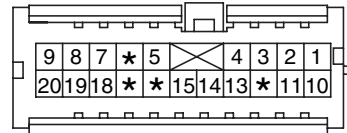

KET\_040III\_20F\_W

**M02-4**

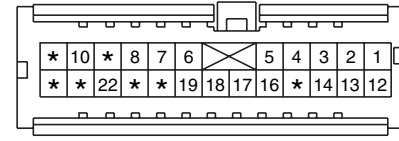

KET\_040III\_24F\_Gr

**M03-2**

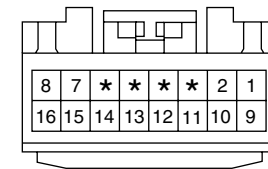

MLX\_040III\_16F\_Gr

**M37**

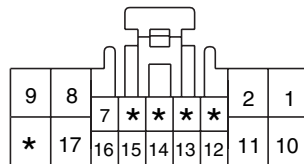

KET\_0509\_18F\_W

**BLANK**

**BLANK**

**BLANK**

**DRL (DAYTIME RUNNING LIGHT)**

**DRL (Daytime Running Light) (4)**

**SD958-4**

**MEMO**

Audio (1)

SD961-1

WITH AMP & AUTO CRUISE

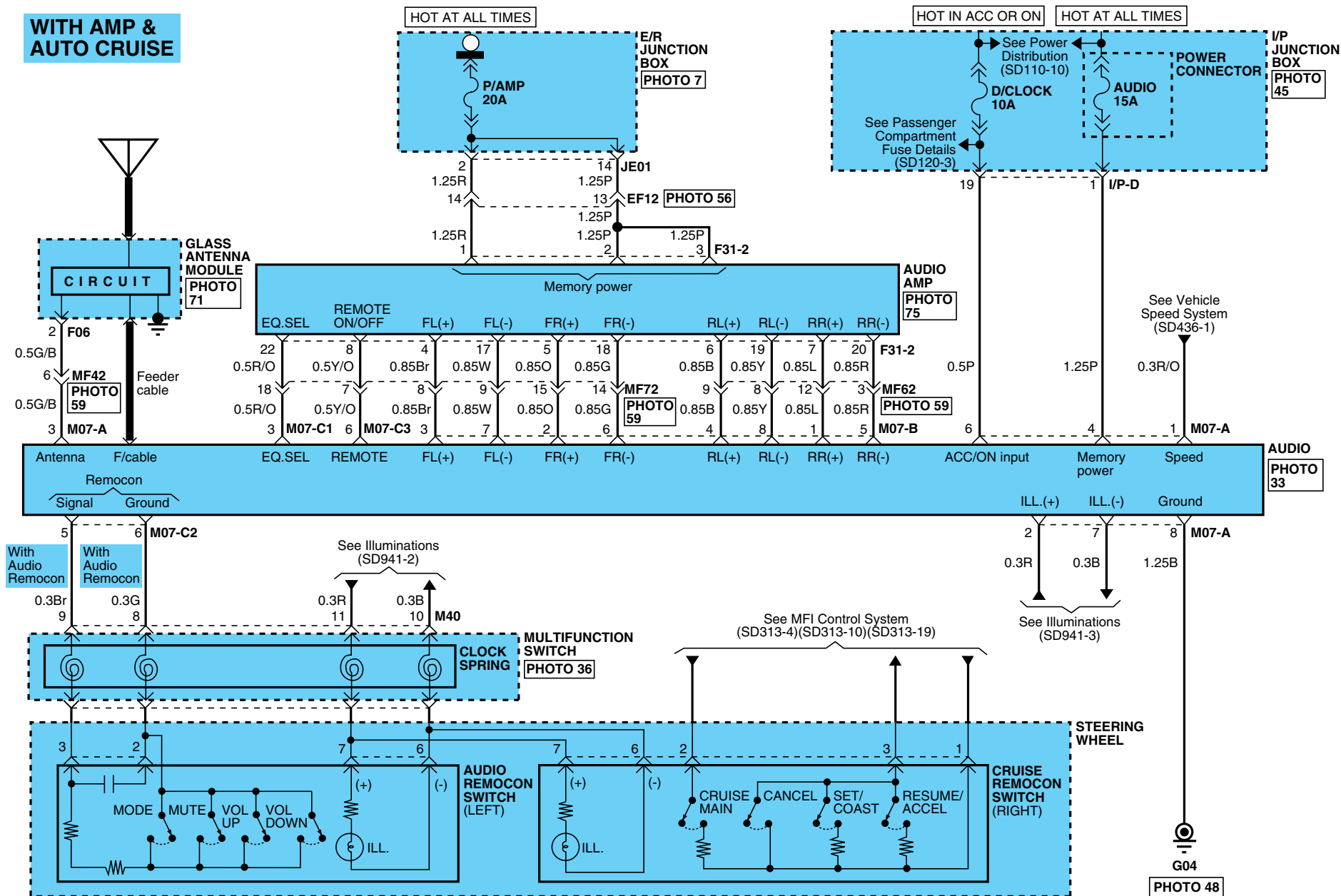





# AUDIO

## Audio (3)

SD961-3

**WITH AMP & W/O AUTO CRUISE**

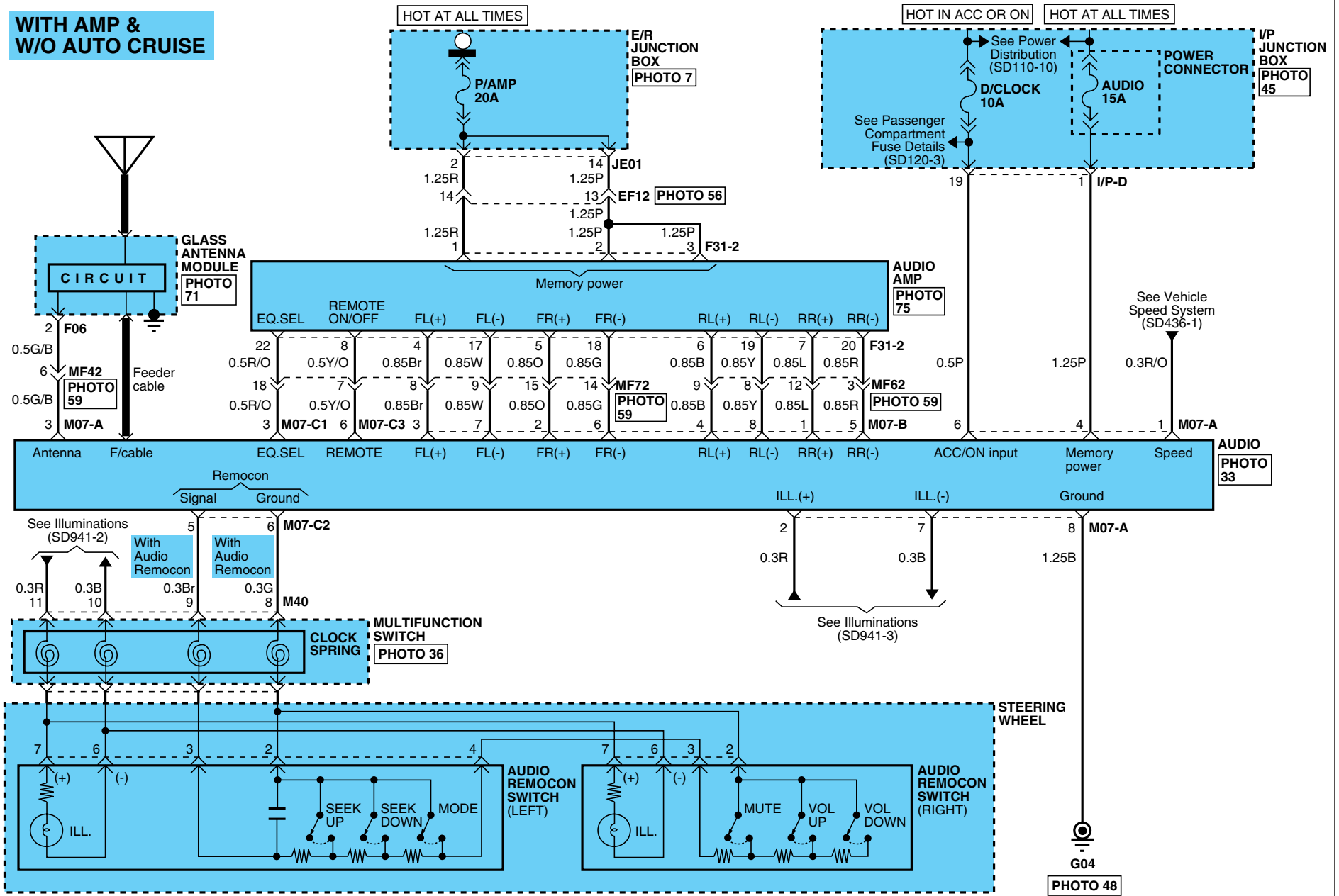

# AUDIO

## Audio (4)

SD961-4

**WITH AMP &  
W/O AUTO CRUISE**

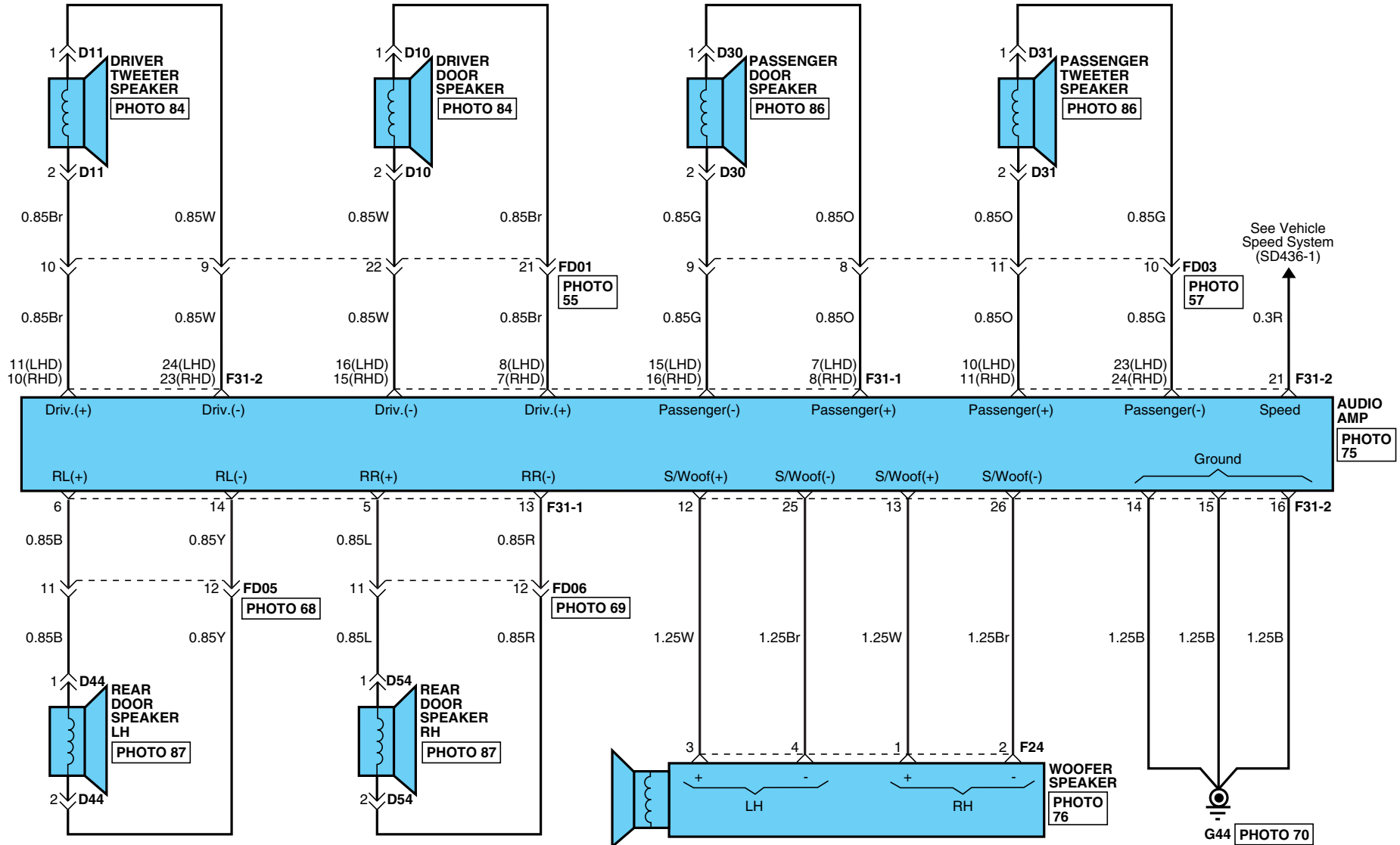

# AUDIO

## Audio (5)

SD961-5

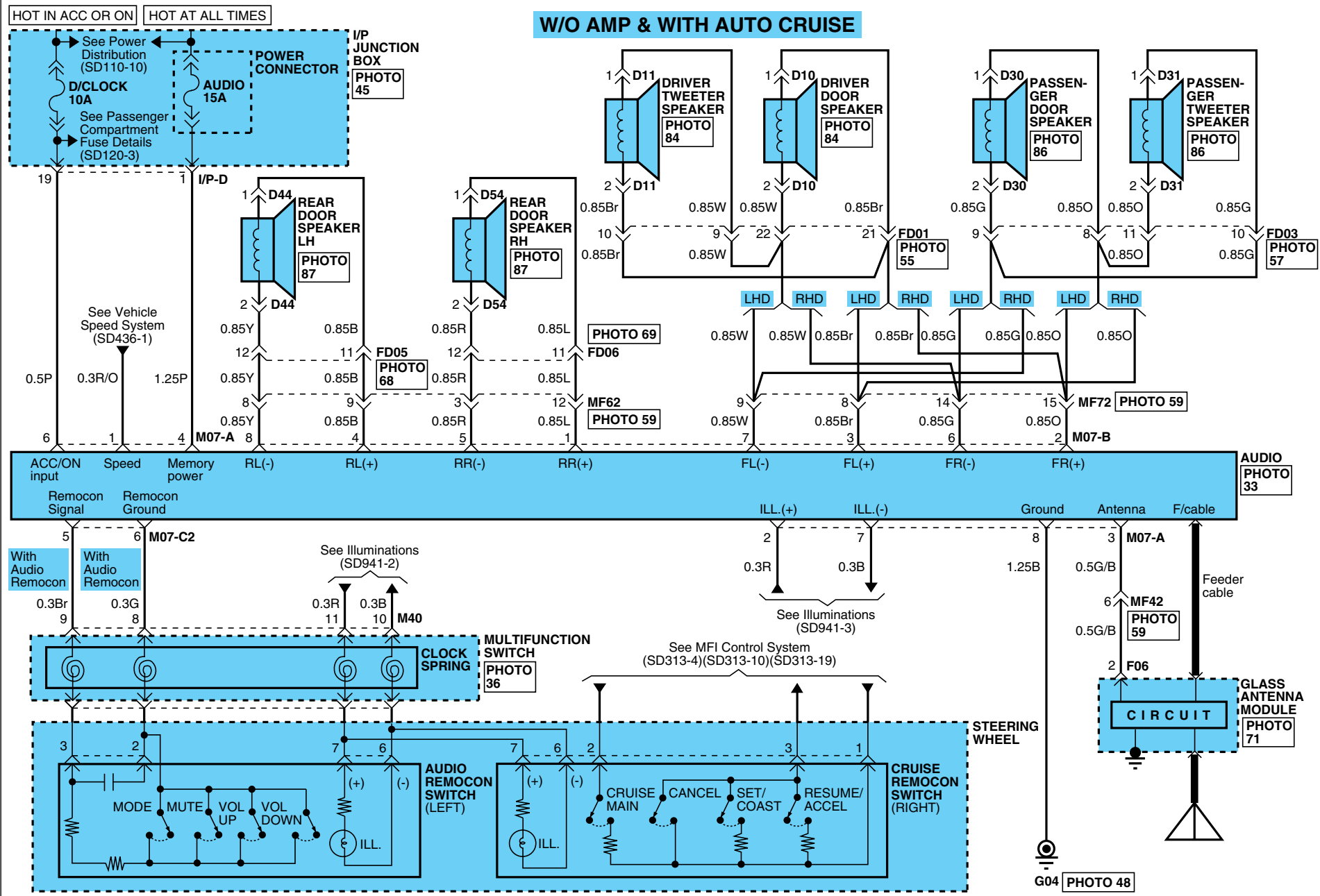

# AUDIO

## Audio (6)

SD961-6

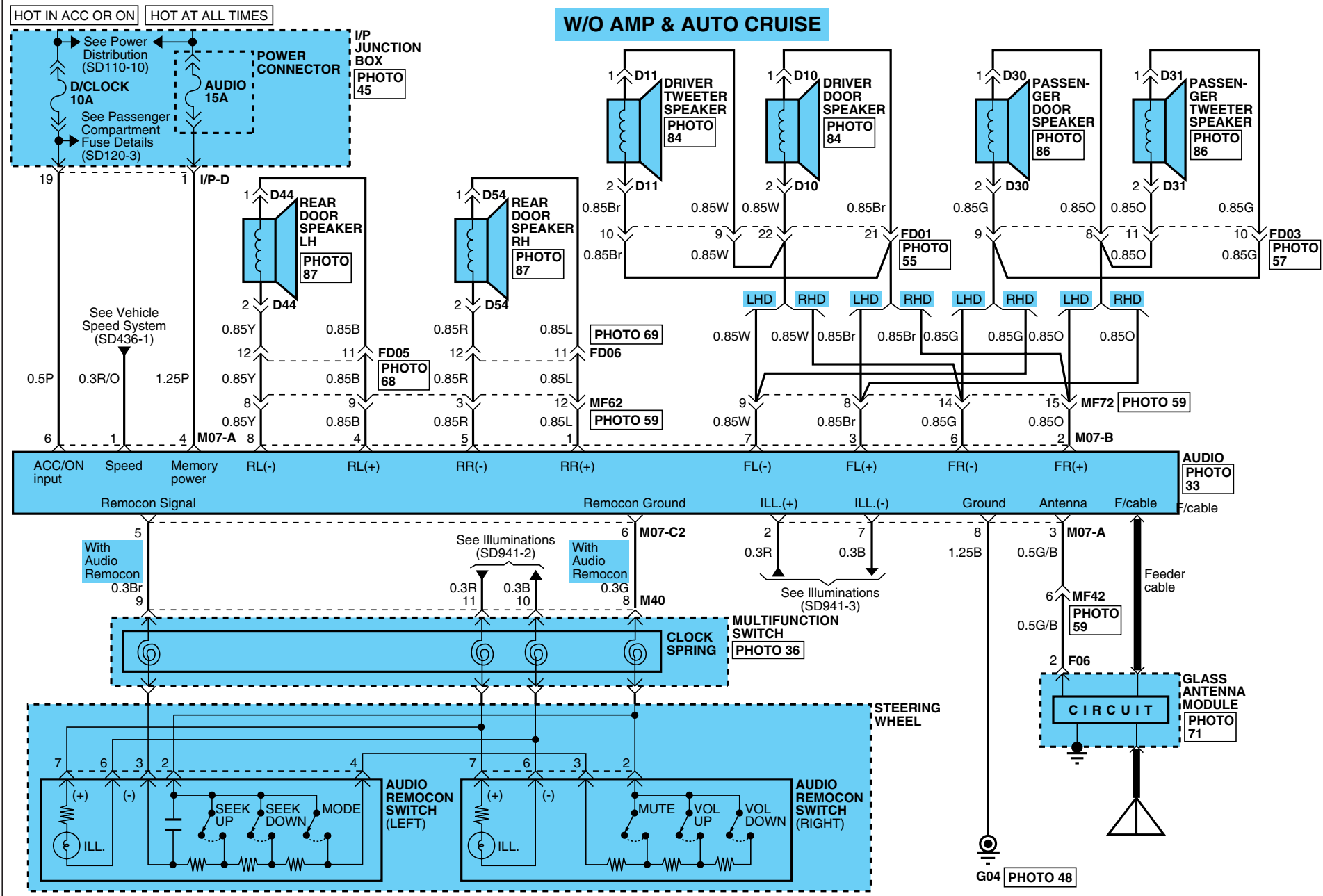

# AUDIO

## Audio (7)

SD961-7

### With AUX & USB

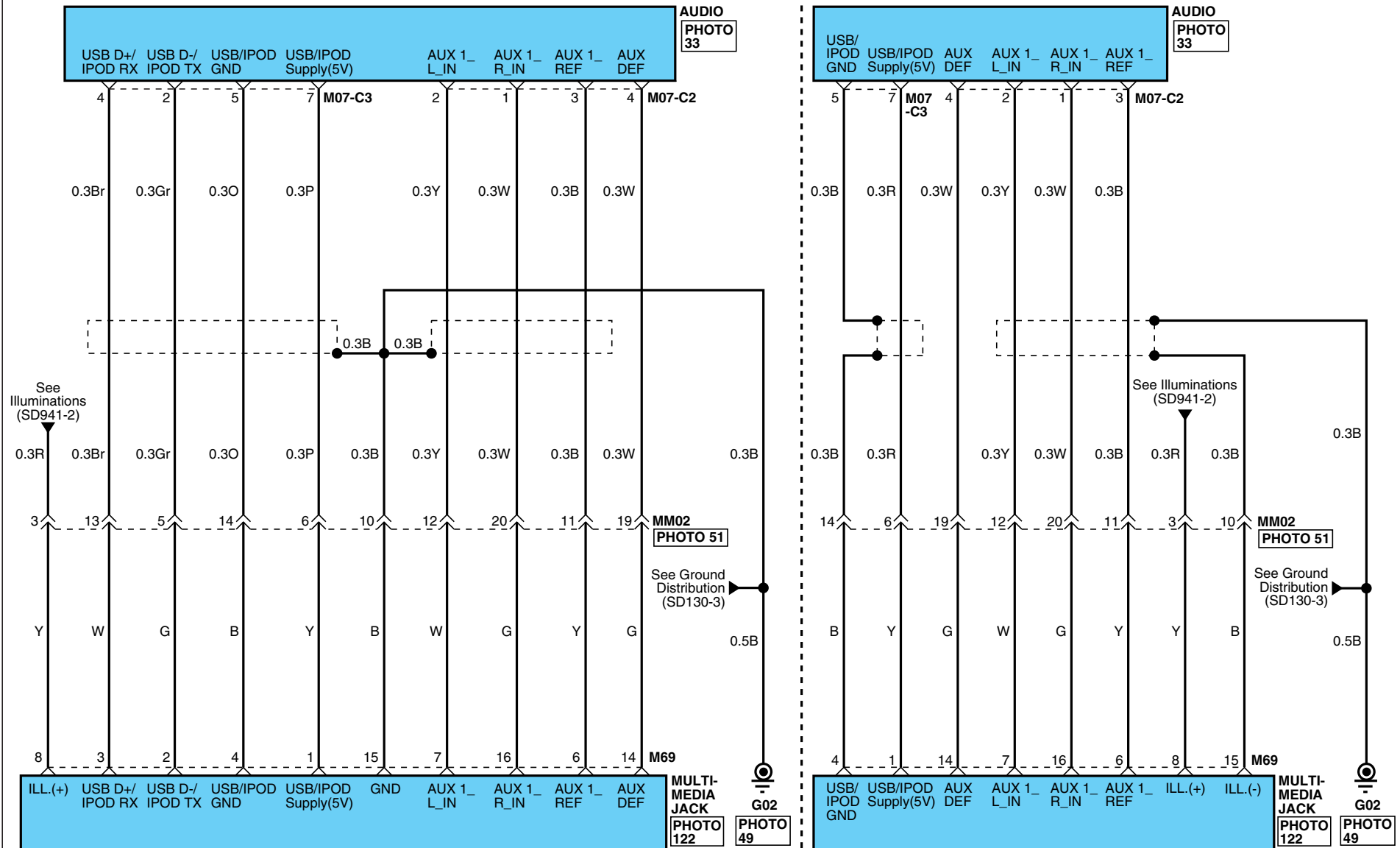

### AUX ONLY



**AUDIO**

**Audio (8)**

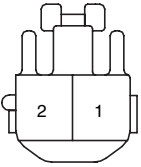
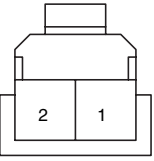
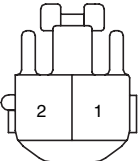
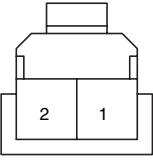
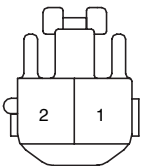
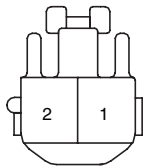
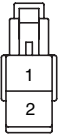
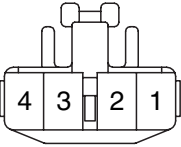
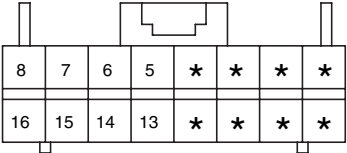
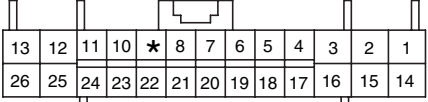
**SD961-8**

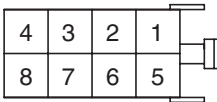
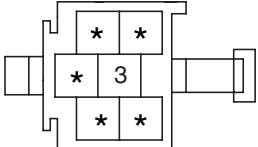
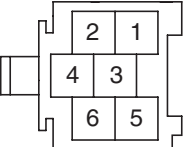
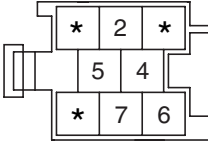
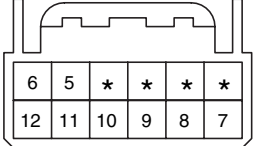
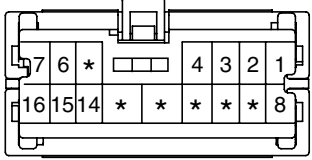
<p><b>D10</b></p>  <p>KET_090III_02F_W_L</p>	<p><b>D11</b></p>  <p>AMP_070_02F_W</p>	<p><b>D30</b></p>  <p>KET_090III_02F_W_L</p>	<p><b>D31</b></p>  <p>AMP_070_02F_W</p>
<p><b>D44</b></p>  <p>KET_090III_02F_W_L</p>	<p><b>D54</b></p>  <p>KET_090III_02F_W_L</p>	<p><b>F06</b></p>  <p>KET_GLASS_02F_B_ANT</p>	<p><b>F24</b></p>  <p>KET_090II_04F_W</p>
<p><b>F31-1</b></p>  <p>AMP_0407MII_16F_GR</p>	<p><b>F31-2</b></p>  <p>AMP_0407MII_26F_GR</p>	<p><b>M07-A</b></p>  <p>AMP_JT_08F_Gr</p>	<p><b>M07-B</b></p>  <p>AMP_JT_08F_Gr</p>
<p><b>M07-C1</b></p>  <p>AMP_MTII_06F_Y</p>	<p><b>M07-C2</b></p>  <p>AMP_MTII_06F_G</p>	<p><b>M07-C3</b></p>  <p>AMP_MTII_06F_L</p>	<p><b>M40</b></p>  <p>AMP_025_12F_W</p>
<p><b>M69</b></p>  <p>KET_040III</p>	<p><b>BLANK</b></p>	<p><b>BLANK</b></p>	<p><b>BLANK</b></p>

Horns (1)

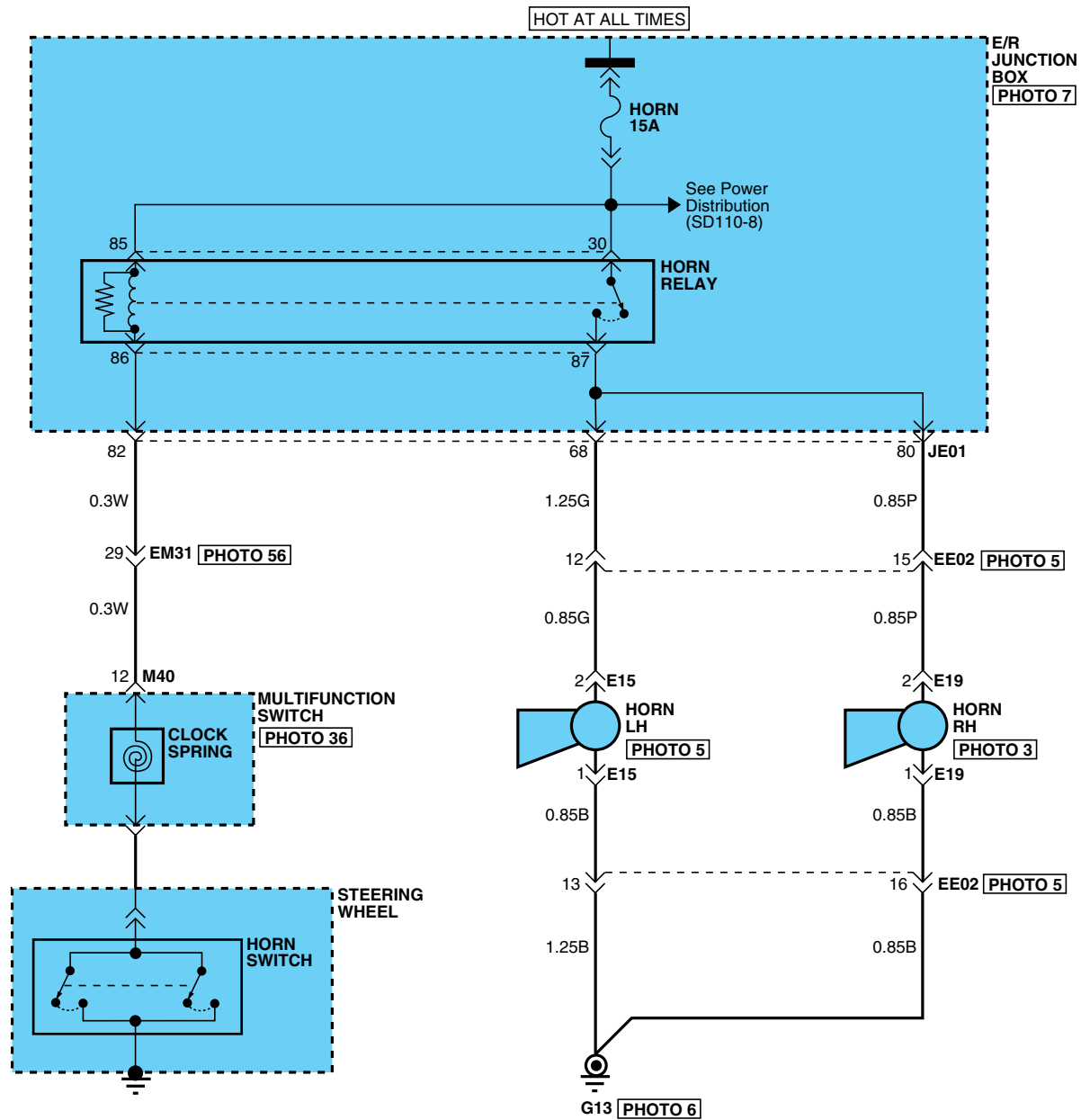



# HORNS

Horns (2)

SD968-2

E15

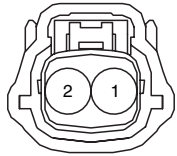

MLX\_HORN\_02F\_B\_FILT

E19

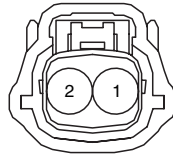

MLX\_HORN\_02F\_B\_FILT

M40

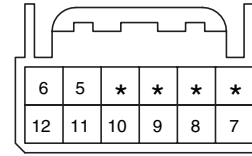

AMP\_025\_12F\_W

BLANK

Blower & A/C Control System (Auto) (1)

SD971-1

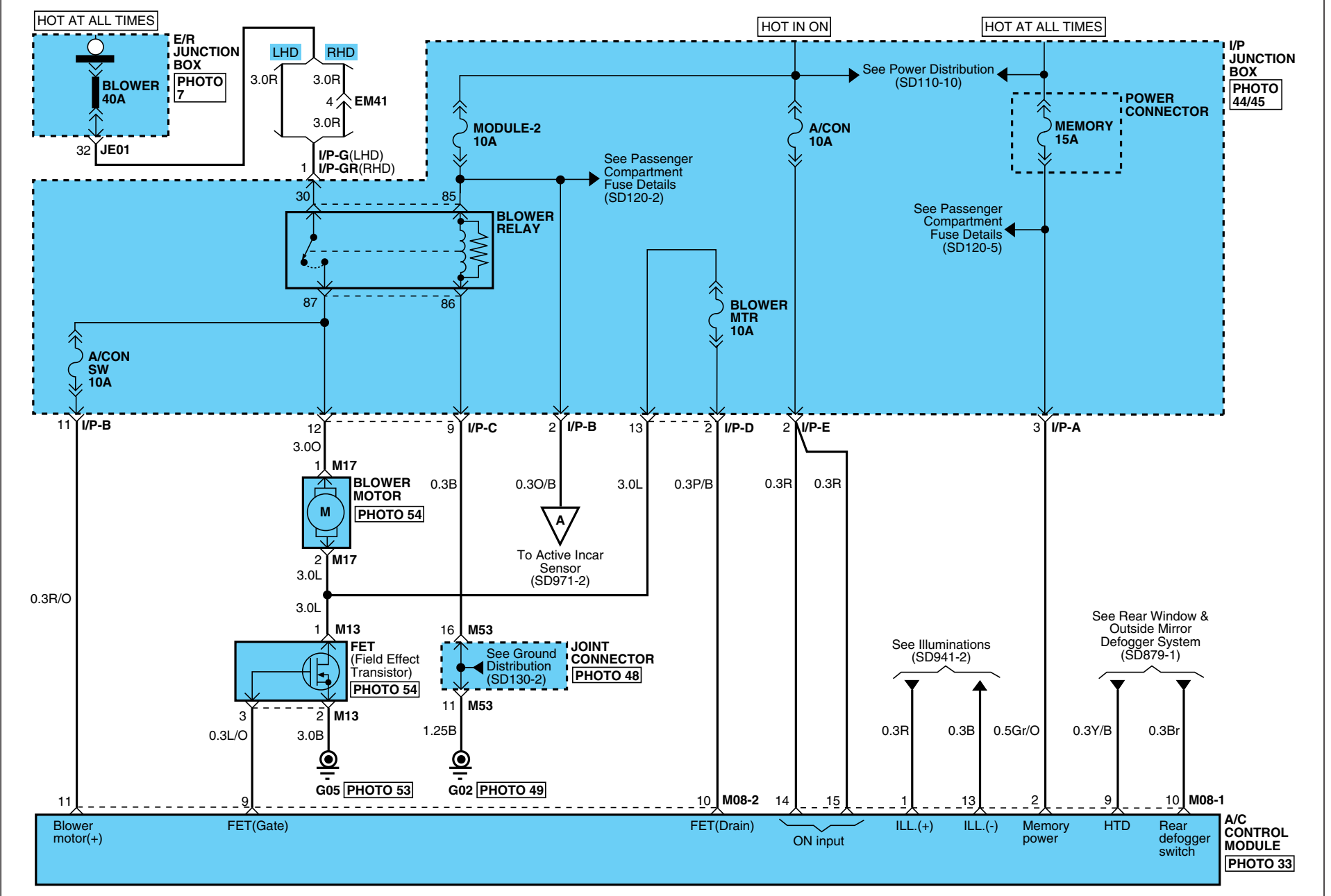

# BLOWER & A/C CONTROL SYSTEM

## Blower & A/C Control System (Auto) (2)

SD971-2

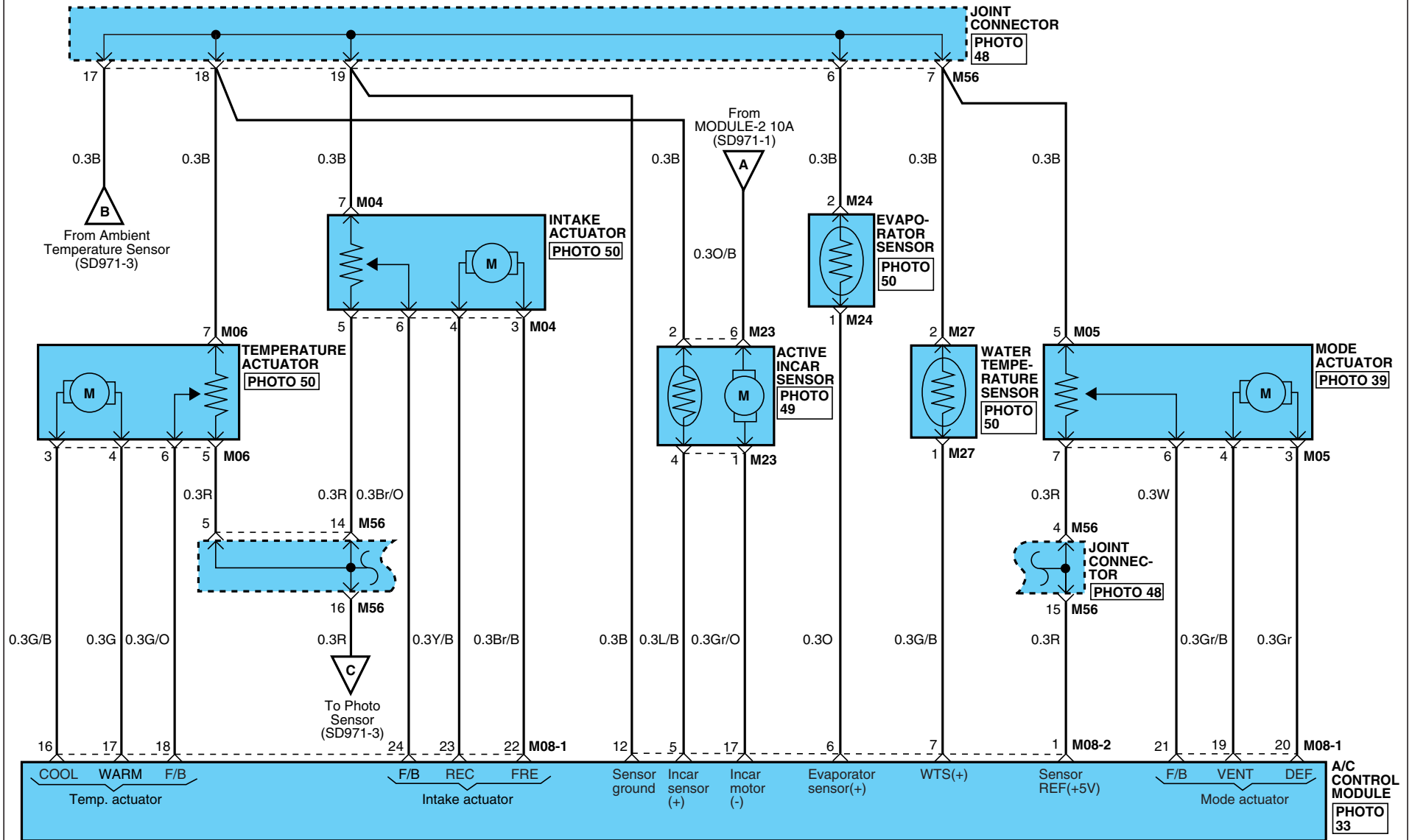



# BLOWER & A/C CONTROL SYSTEM

## Blower & A/C Control System (Auto) (4)

SD971-4

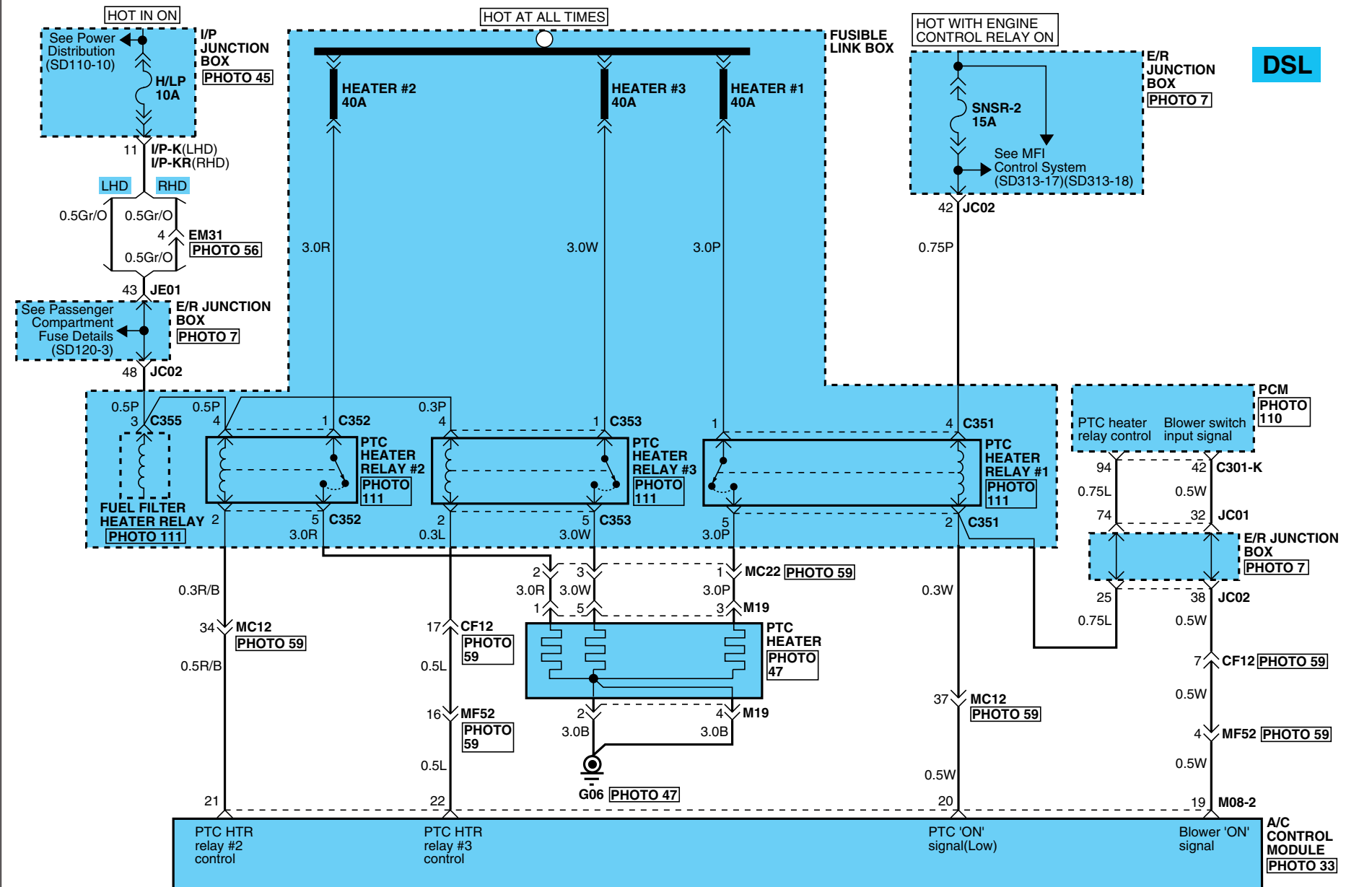

\* P.T.C (Positive Temperature Coefficient)

# BLOWER & A/C CONTROL SYSTEM

## Blower & A/C Control System (Auto) (5)

SD971-5

**C01-A**

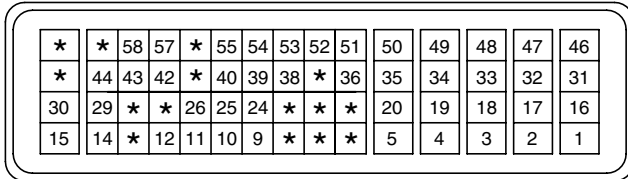

AMP\_TCU\_60F\_B\_SIE

**C01-K**

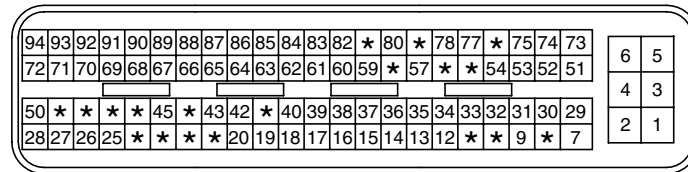

AMP\_PCU\_94F\_B\_SIE

**C201-A**

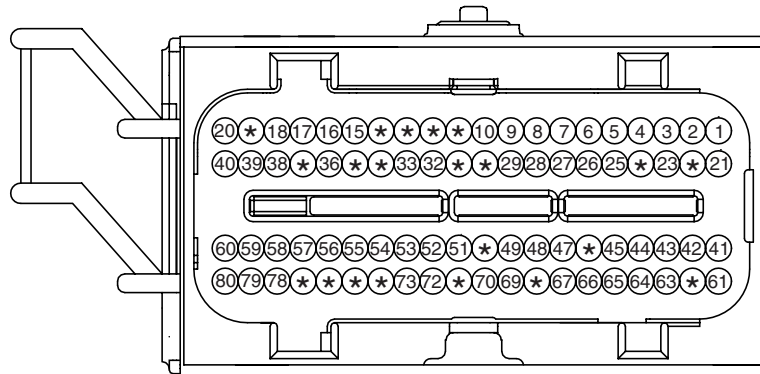

PKD\_ECU\_80F\_GR\_1

**C08/C208/C308**



KUM\_NMWP\_01F\_B

**C47**

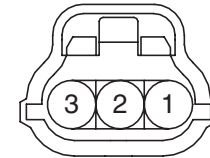

KET\_040WP\_03F\_B

**C301-K**

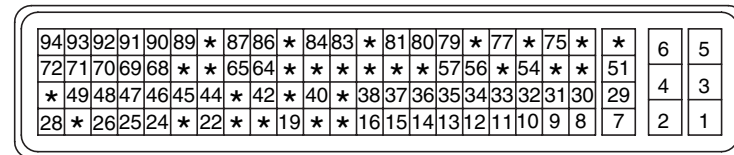

AMP\_PCU\_94F\_B\_SIE

**C351/C352/C353**

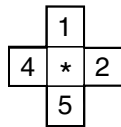

CR05F019

**C355**

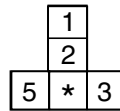

CR05F011

**E10/E11**

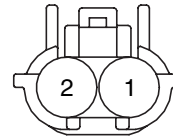

KET\_SWP\_02F\_B

**M04**

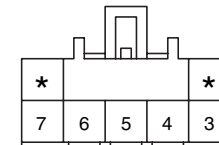

KUM\_CDR\_07F\_W

**M05**

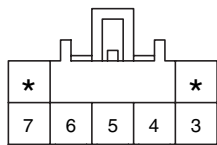

KUM\_CDR\_07F\_W

**M06**

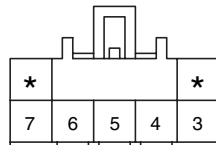

KUM\_CDR\_07F\_W

**M08-1**

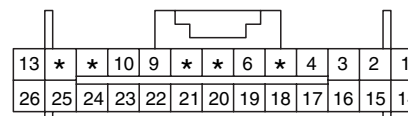

AMP\_0407\_26F\_W\_HD

**M08-2**

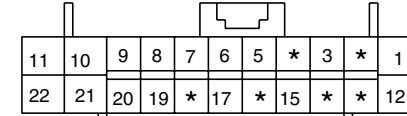

AMP\_0407\_22F\_W\_HD

# BLOWER & A/C CONTROL SYSTEM

## Blower & A/C Control System (Auto) (6)

SD971-6

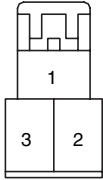
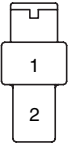
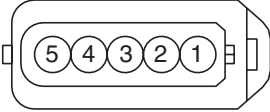
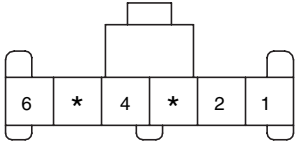
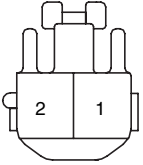
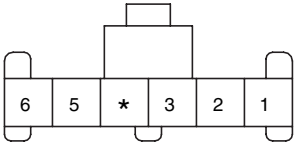
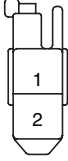
<p><b>M13</b></p>  <p>KUM_DSD_03F_W</p>	<p><b>M17</b></p>  <p>KET_250_02F_W</p>	<p><b>M19</b></p>  <p>AMP_375_05F_B</p>	<p><b>M23</b></p>  <p>KET_91A_06F_W</p>
<p><b>M24</b></p>  <p>KET_090II_02F_W_L</p>	<p><b>M25</b></p>  <p>KET_91A_06F_W</p>	<p><b>M27</b></p>  <p>KET_090II_02F_W_SPK</p>	<p><b>BLANK</b></p>

**Blower & A/C Control System (Manual) (1)**

**SD971-7**

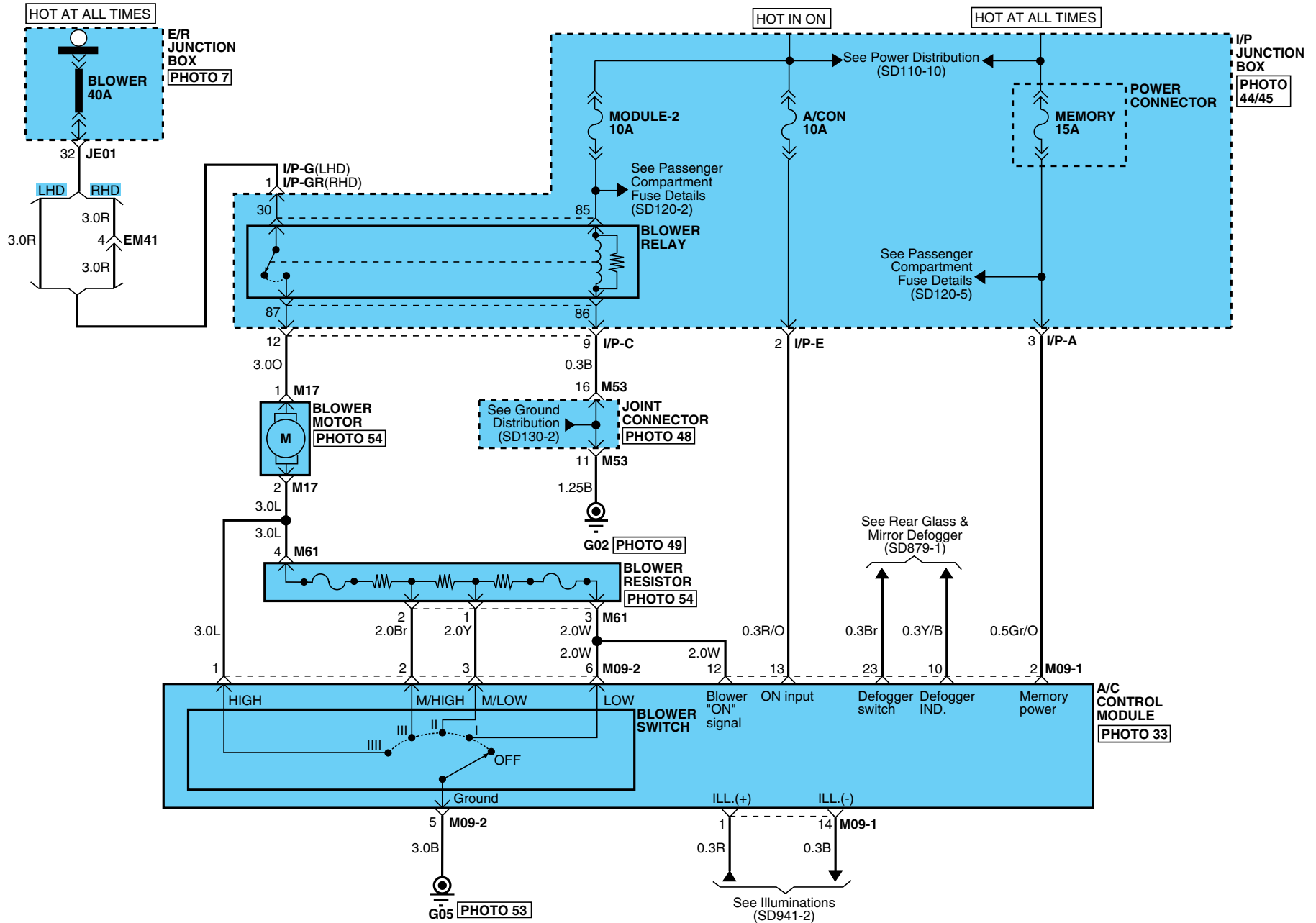





# BLOWER & A/C CONTROL SYSTEM

## Blower & A/C Control System (Manual) (3)

SD971-9

**DSL**

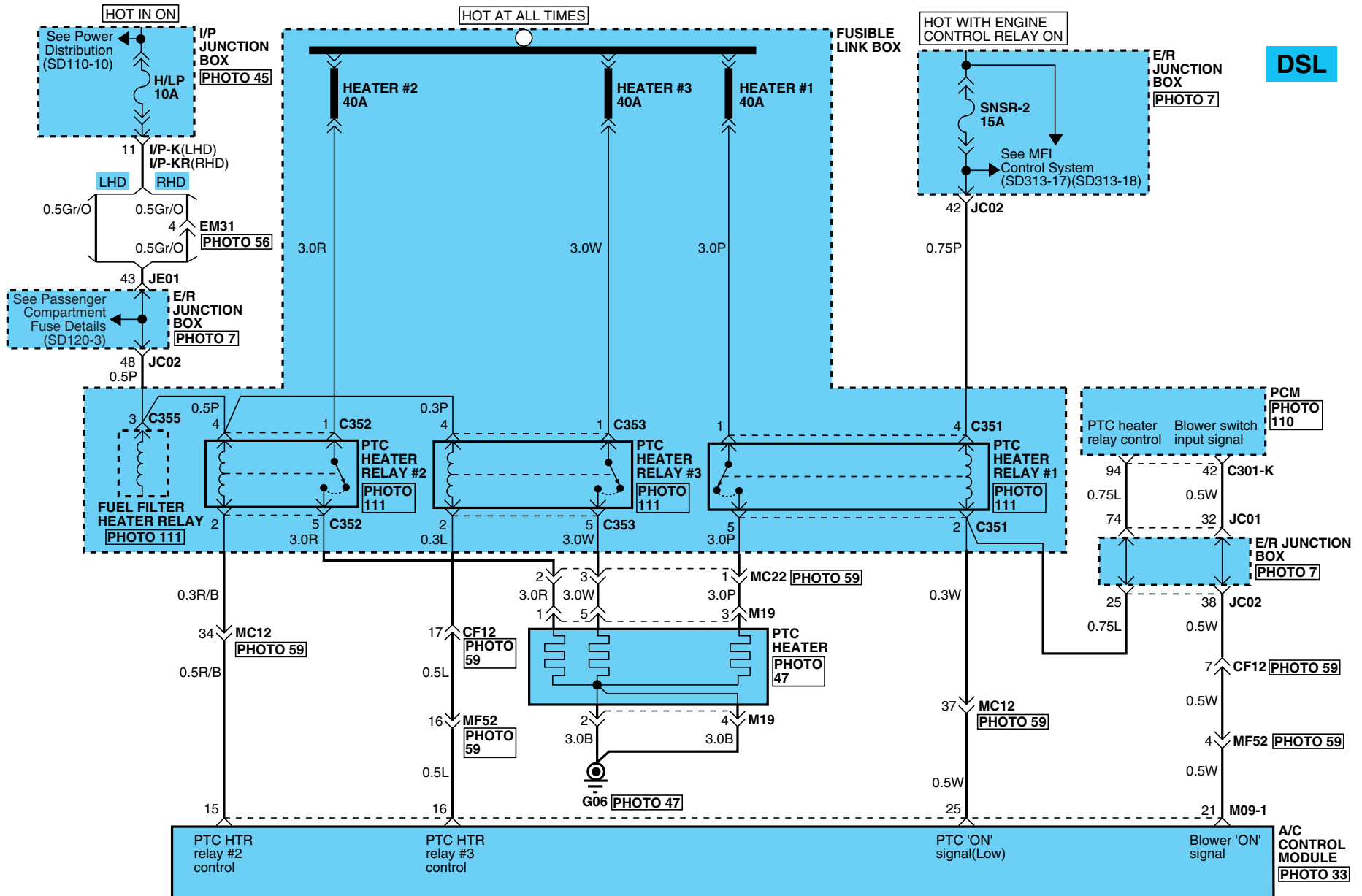

\* P.T.C (Positive Temperature Coefficient)

# BLOWER & A/C CONTROL SYSTEM

## Blower & A/C Control System (Manual) (4)

SD971-10

**C01-A**

*	*	58	57	*	55	54	53	52	51	50	49	48	47	46
*	44	43	42	*	40	39	38	*	36	35	34	33	32	31
30	29	*	*	26	25	24	*	*	*	20	19	18	17	16
15	14	*	12	11	10	9	*	*	*	5	4	3	2	1

AMP\_TCU\_60F\_B\_SIE

**C01-K**

94	93	92	91	90	89	88	87	86	85	84	83	82	*	80	*	78	77	*	75	74	73	6	5
72	71	70	69	68	67	66	65	64	63	62	61	60	59	*	57	*	*	54	53	52	51	4	3
50	*	*	*	*	45	*	43	42	*	40	39	38	37	36	35	34	33	32	31	30	29	2	1
28	27	26	25	*	*	*	*	20	19	18	17	16	15	14	13	12	*	*	9	*	7		

AMP\_PCU\_94F\_B\_SIE

**C201-A**

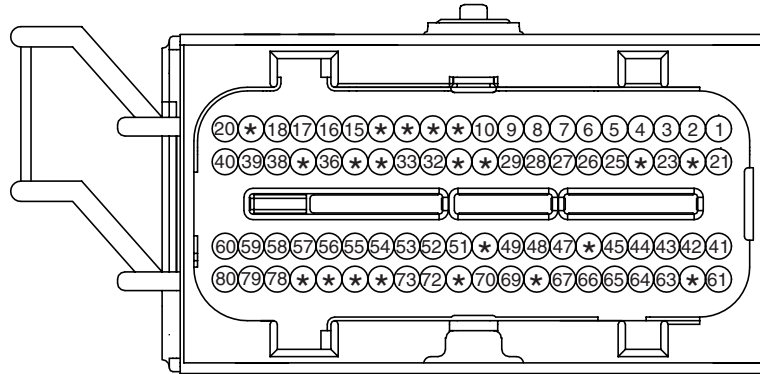

PKD\_ECU\_80F\_GR\_1

**C08/C208/C308**



KUM\_NMWP\_01F\_B

**C47**

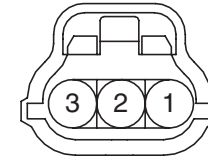

KET\_040WP\_03F\_B

**C301-K**

94	93	92	91	90	89	*	87	86	*	84	83	*	81	80	79	*	77	*	75	*	*	6	5
72	71	70	69	68	*	*	65	64	*	*	*	*	*	57	56	*	54	*	*	51	4	3	
*	49	48	47	46	45	44	*	42	*	40	*	38	37	36	35	34	33	32	31	30	29	2	1
28	*	26	25	24	*	22	*	*	19	*	*	16	15	14	13	12	11	10	9	8	7		

AMP\_PCU\_94F\_B\_SIE

**C351/C352/C353**

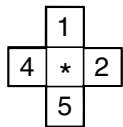

CR05F019

**C355**

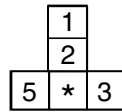

CR05F011

**M04**

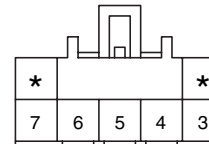

KUM\_CDR\_07F\_W

**M05**

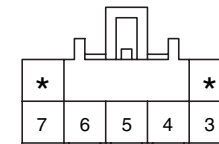

KUM\_CDR\_07F\_W

**M06**

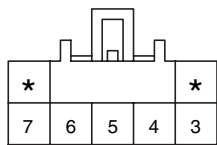

KUM\_CDR\_07F\_W

**M09-1**

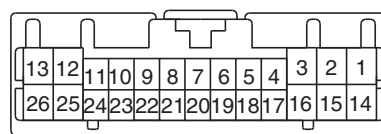

KET\_0407\_26F\_W

**M09-2**

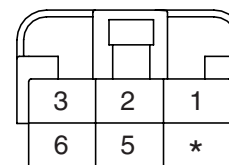

KET\_250DL\_06F\_W

**M17**

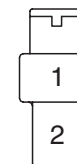

KET\_250\_02F\_W

# BLOWER & A/C CONTROL SYSTEM

Blower & A/C Control System (Manual) (5)

SD971-11

M19

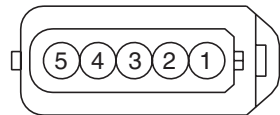

AMP\_375\_05F\_B

M24

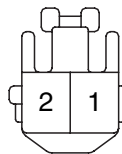

KET\_090II\_02F\_W\_L

M61

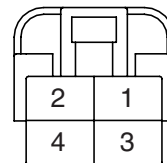

KET\_250DL\_04F\_W

BLANK

**BLOWER & A/C CONTROL SYSTEM**

**Blower & A/C Control System (Manual) (6)**

**SD971-12**

**MEMO**

Front Wiper & Washer (1)

SD981-1

W/O RAIN SENSOR

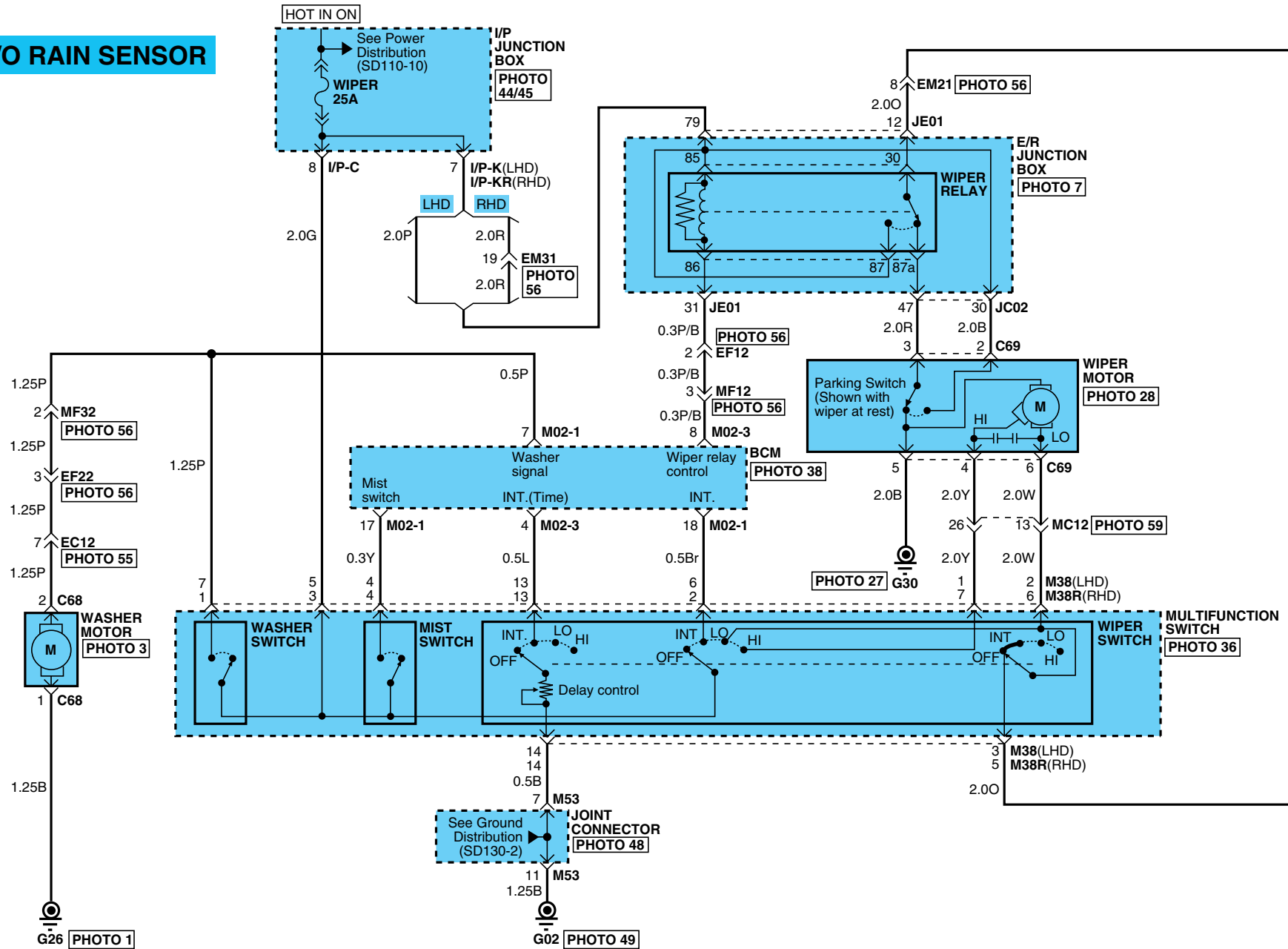

# FRONT WIPER & WASHER

## Front Wiper & Washer (2)

SD981-2

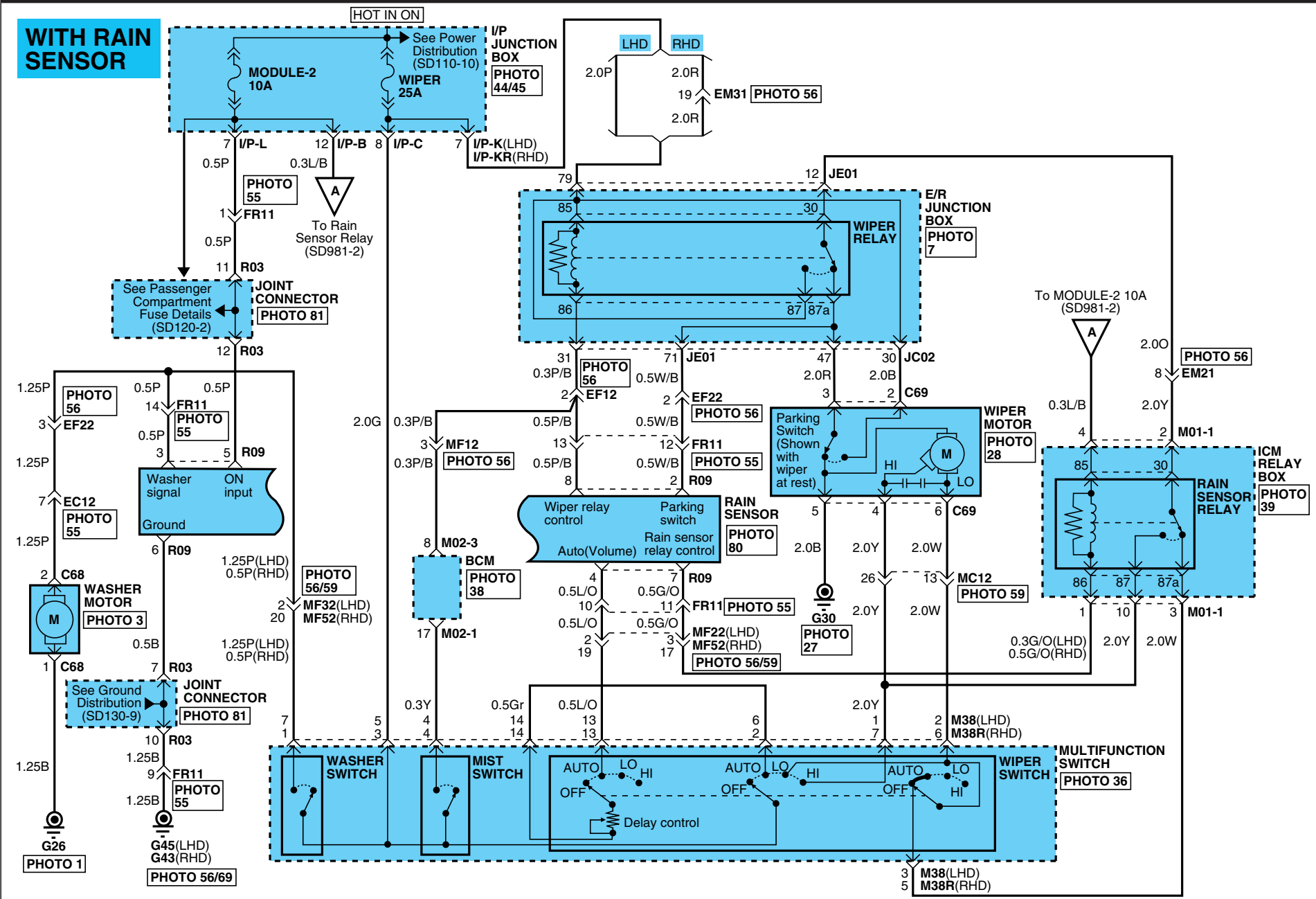

# FRONT WIPER & WASHER

## Front Wiper & Washer (3)

SD981-3

**C68**

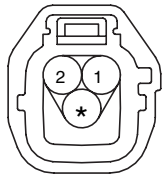

KET\_090IWP\_03F\_B

**C69**

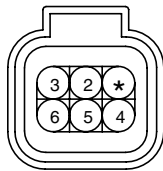

AMP\_MCPE\_06F\_B

**M01-1**

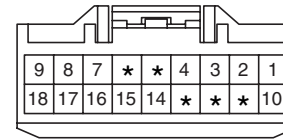

AMP\_090III\_18F\_W

**M02-1**

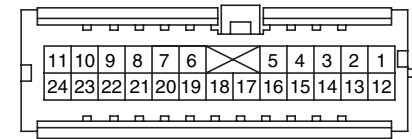

KET\_040III\_24F\_W

**M02-3**

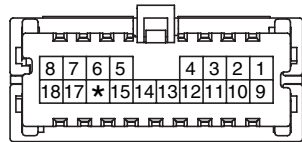

KET\_040III\_18F\_W

**M38**

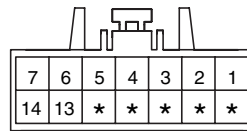

KET\_090II\_14F\_W\_SW

**M38R**

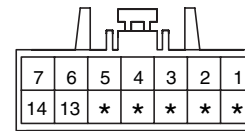

KET\_090II\_14F\_W\_SW

**R09**

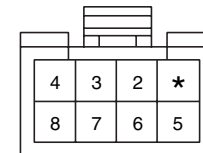

MLX\_118\_08F\_B



Component Locations(1)

CL-1

PHOTO.1

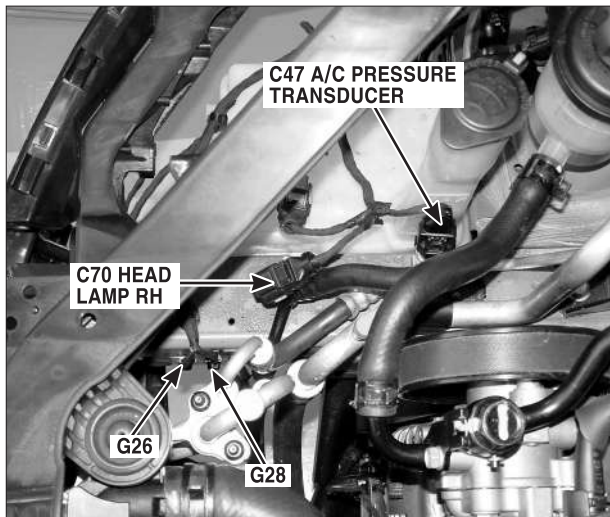

PHOTO.2



PHOTO.3

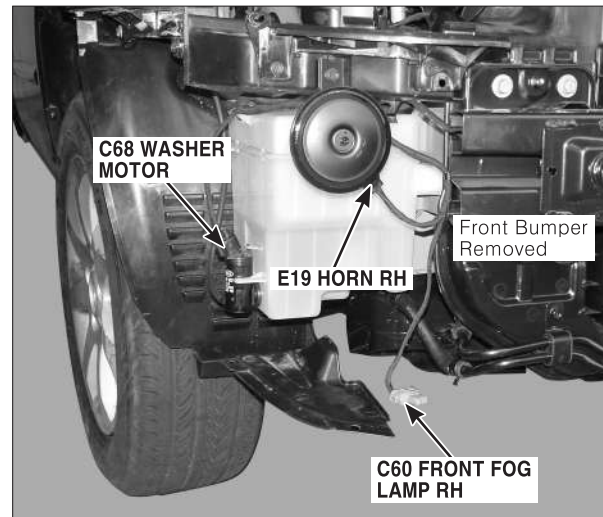

PHOTO.4

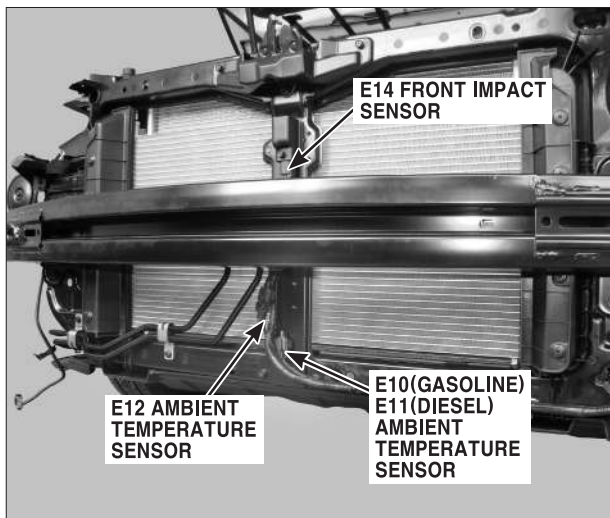

PHOTO.5

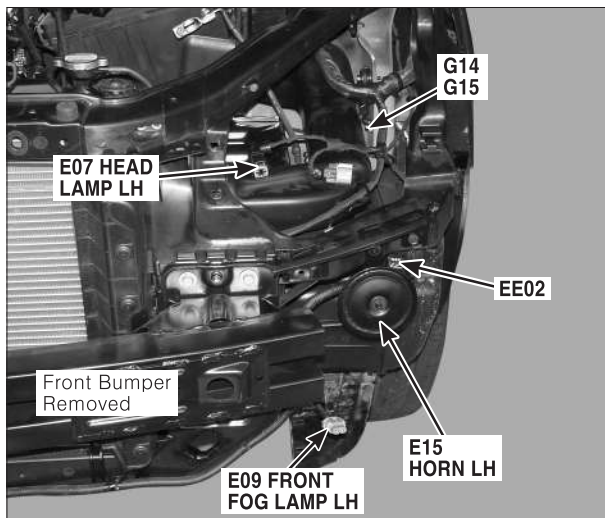
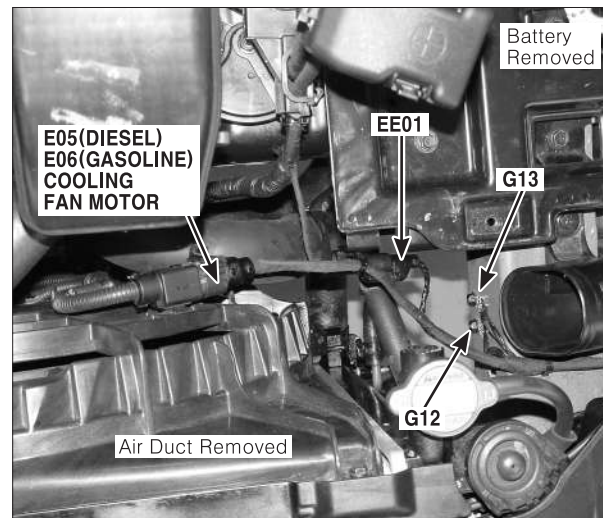

PHOTO.6



# COMPONENT LOCATIONS

## Component Locations(2)

CL-2

PHOTO.7

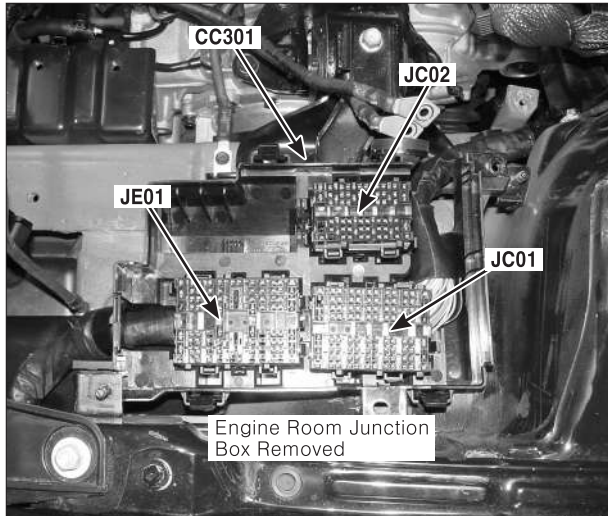

PHOTO.8

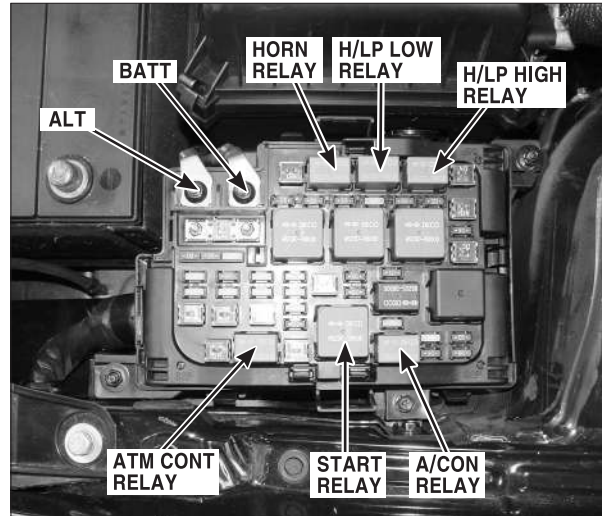

PHOTO.9

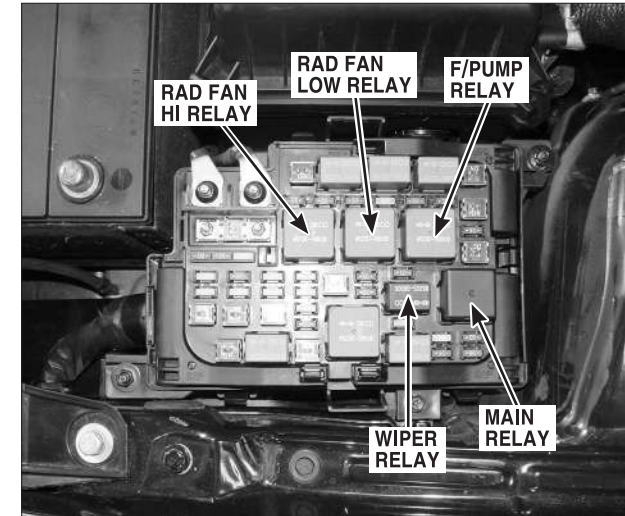

PHOTO.10

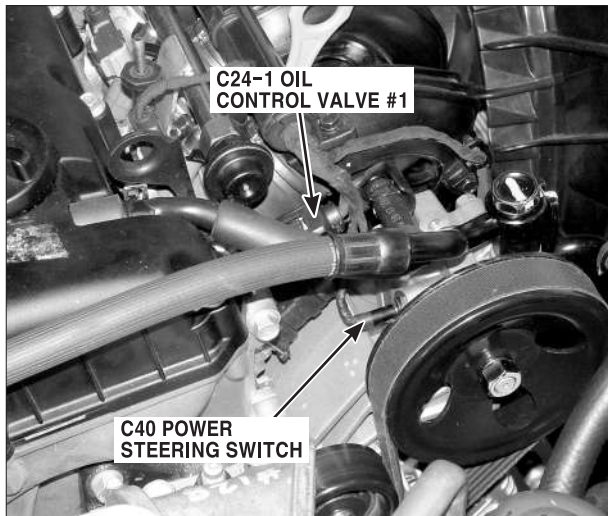

PHOTO.11

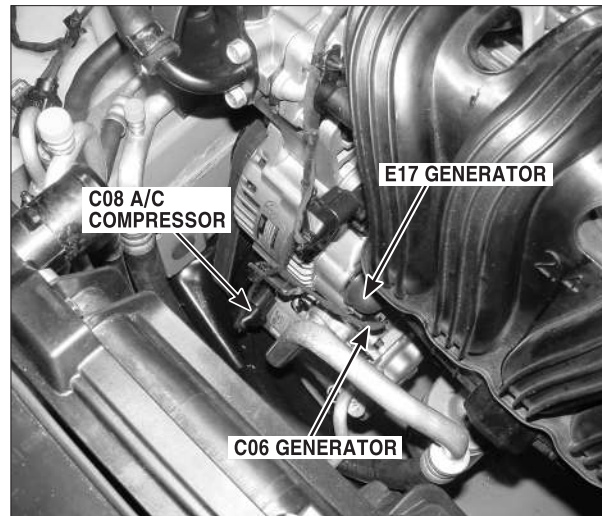
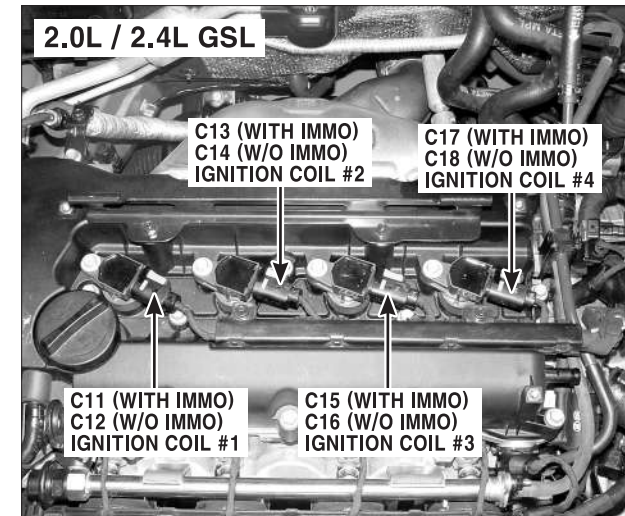

PHOTO.12





# COMPONENT LOCATIONS

## Component Locations(3)

CL-3

PHOTO.13

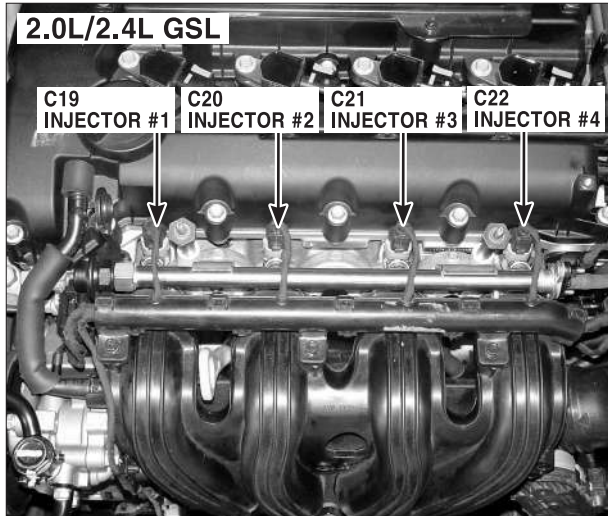

PHOTO.14

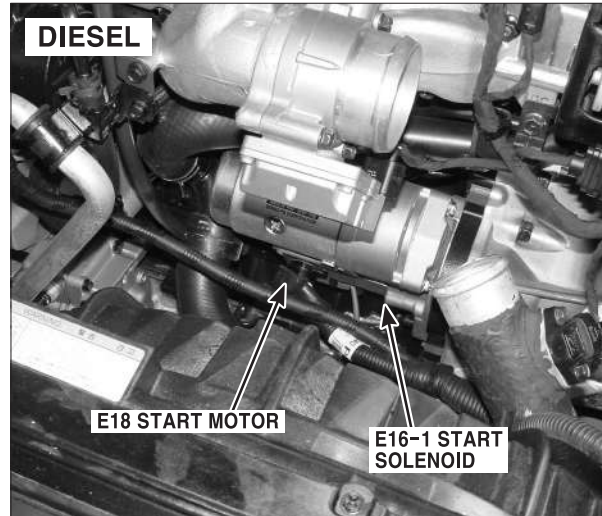

PHOTO.15

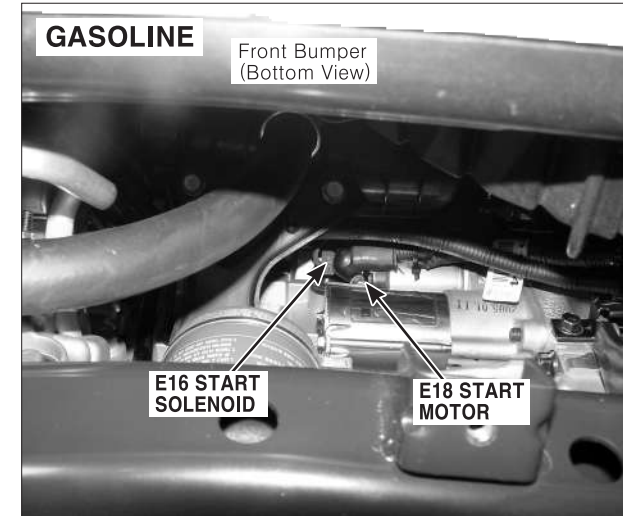

PHOTO.16

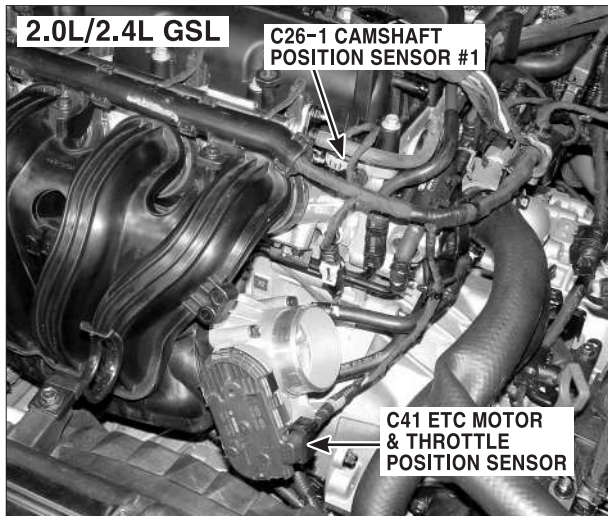

PHOTO.17

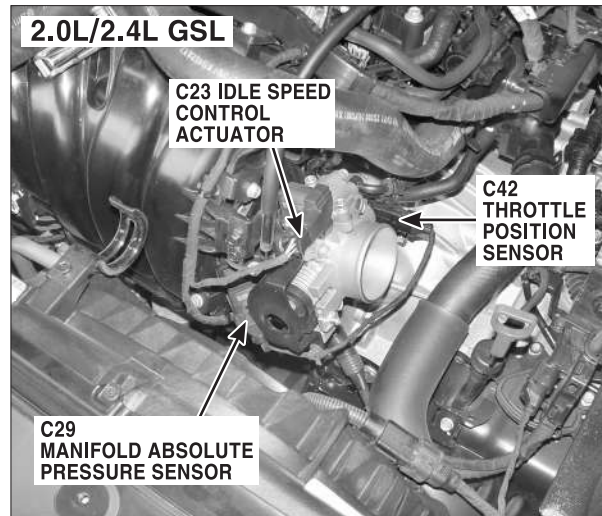
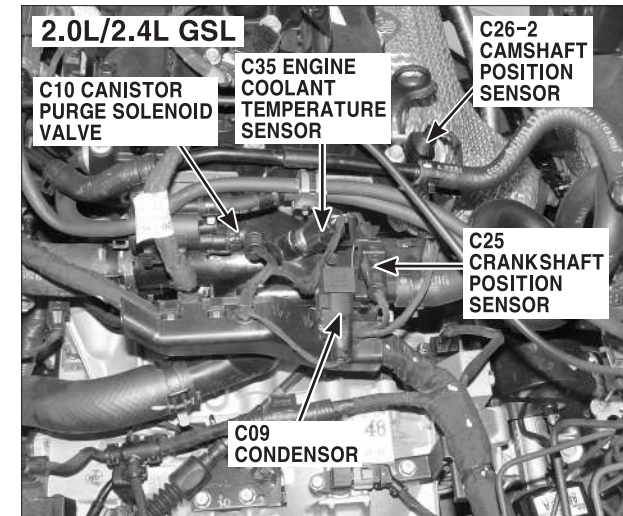

PHOTO.18





# COMPONENT LOCATIONS

## Component Locations(4)

CL-4

PHOTO.19

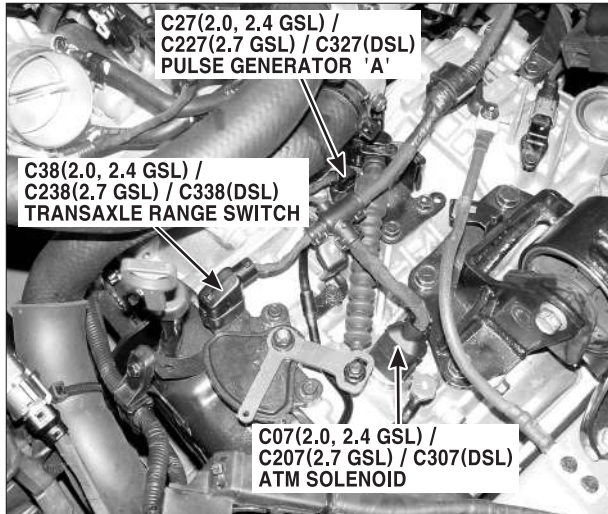

PHOTO.20



PHOTO.21



PHOTO.22



PHOTO.23



PHOTO.24

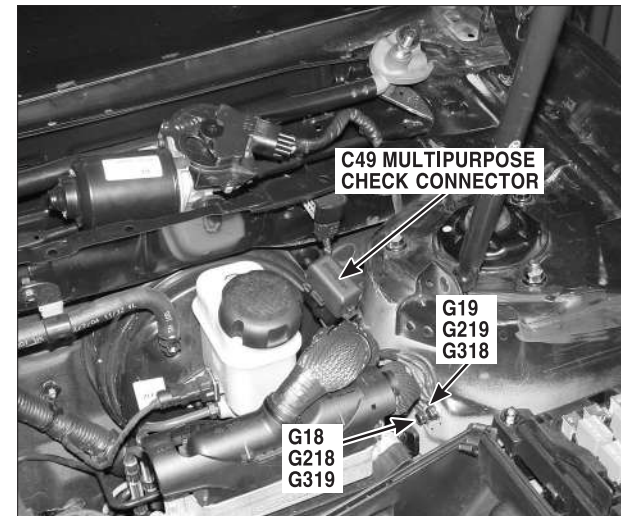

# COMPONENT LOCATIONS

## Component Locations(5)

CL-5

PHOTO.25

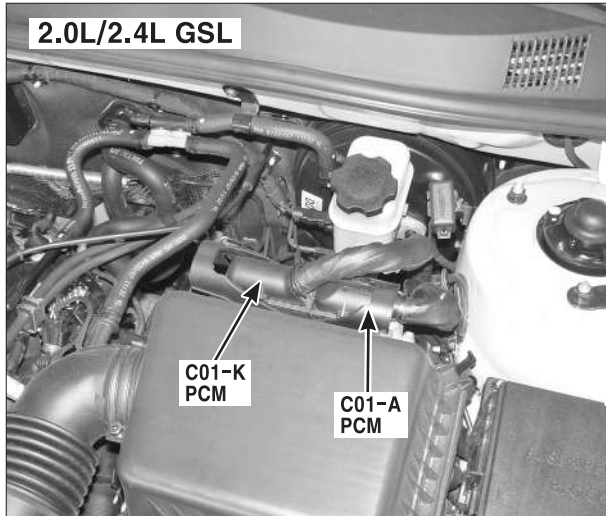

PHOTO.26

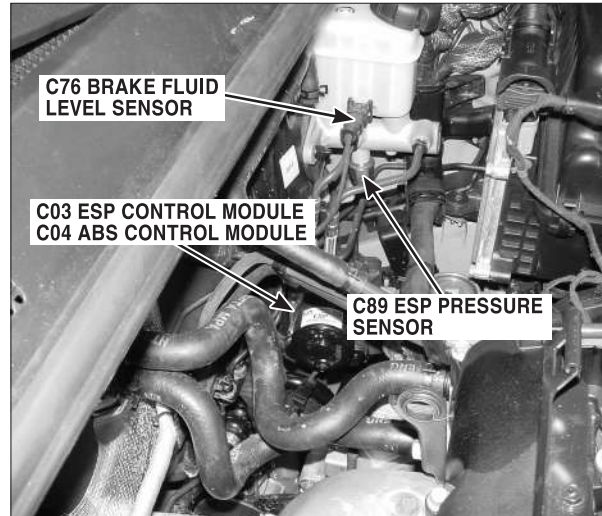

PHOTO.27

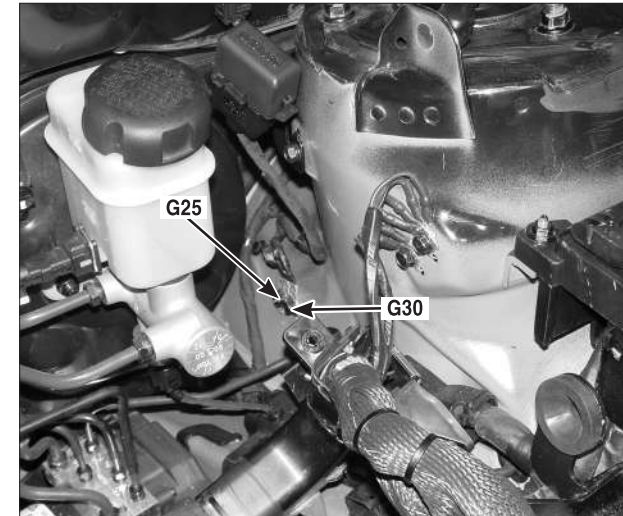

PHOTO.28

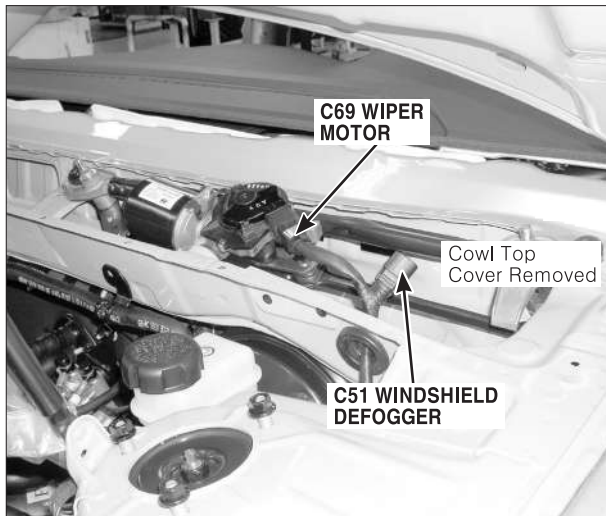

PHOTO.29

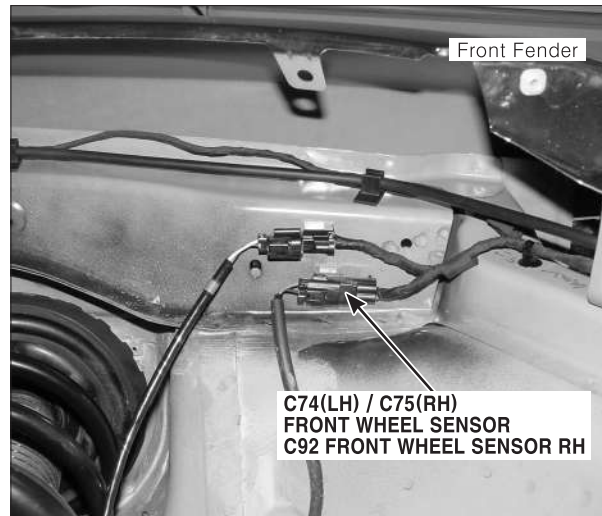

PHOTO.30





# COMPONENT LOCATIONS

## Component Locations(6)

CL-6

PHOTO.31

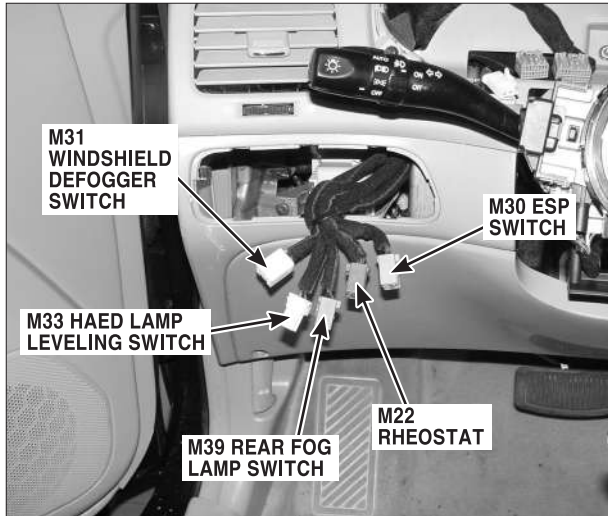

PHOTO.32

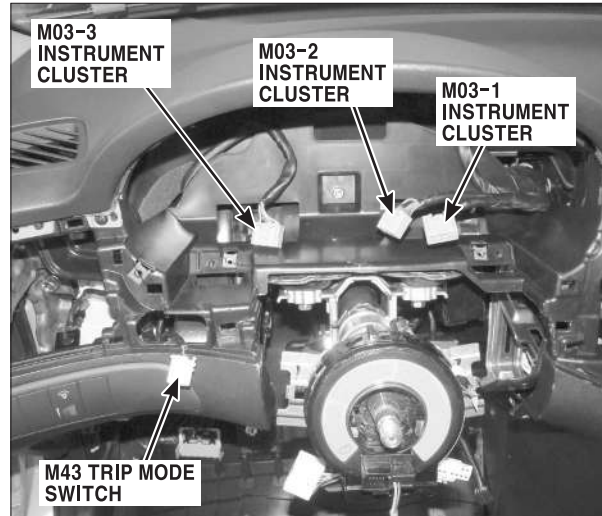

PHOTO.33

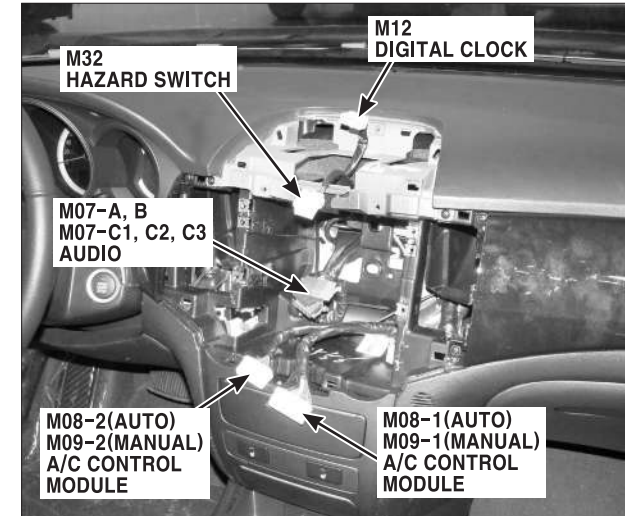

PHOTO.34

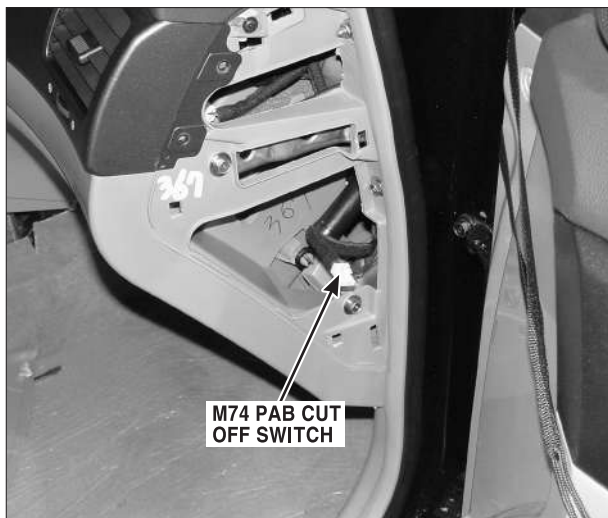

PHOTO.35

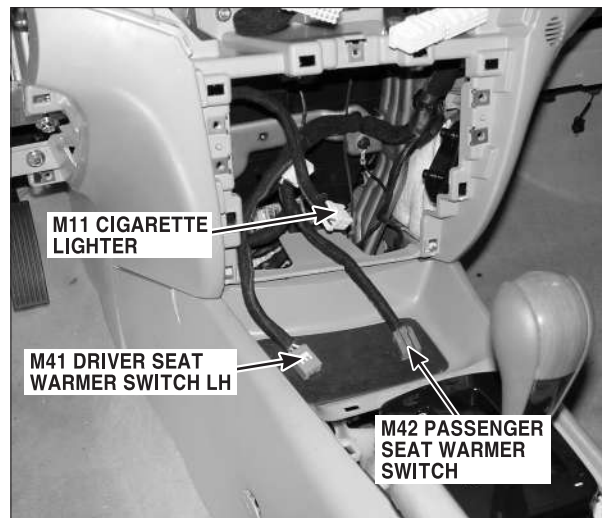
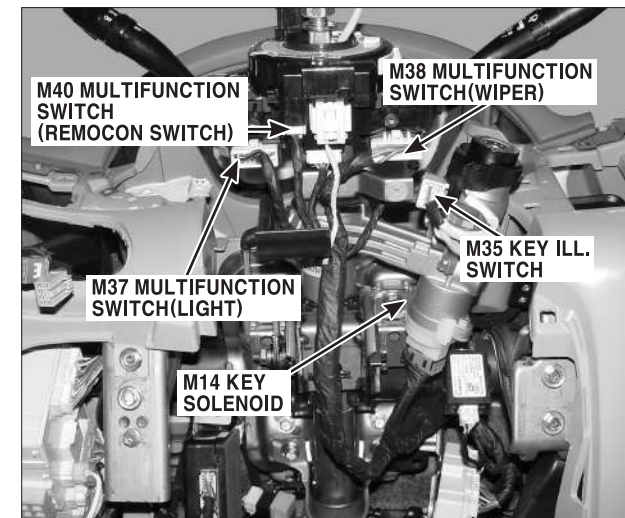

PHOTO.36



# COMPONENT LOCATIONS

## Component Locations(7)

CL-7

PHOTO.37

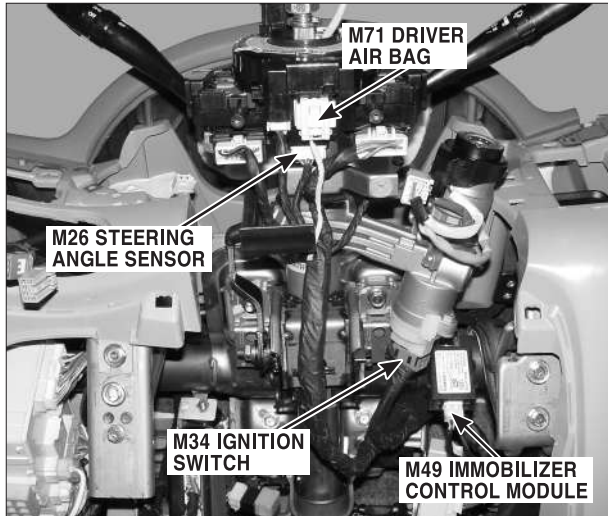

PHOTO.38

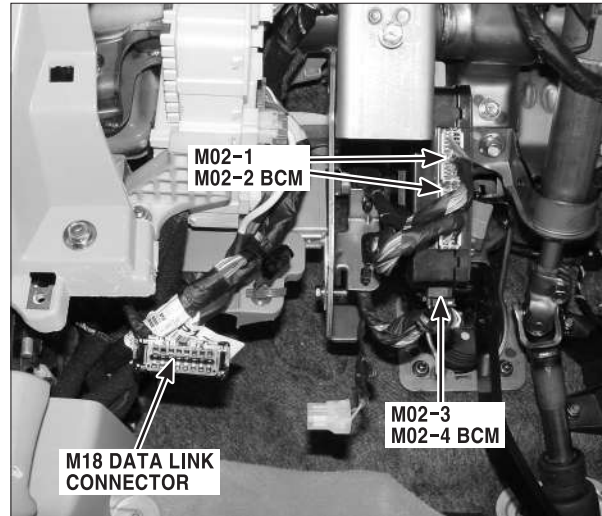

PHOTO.39

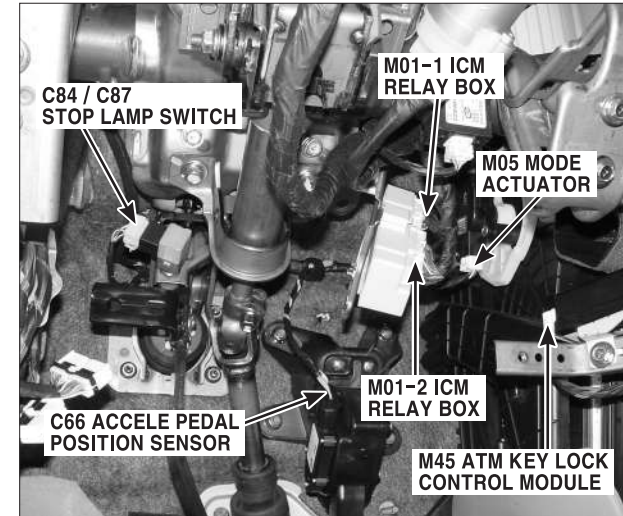

PHOTO.40

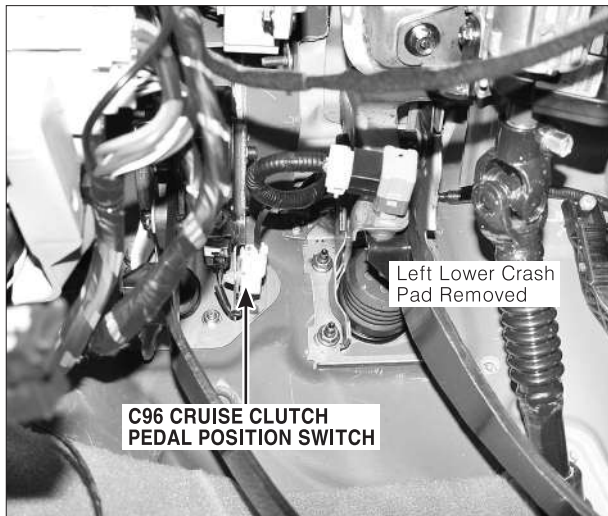

PHOTO.41

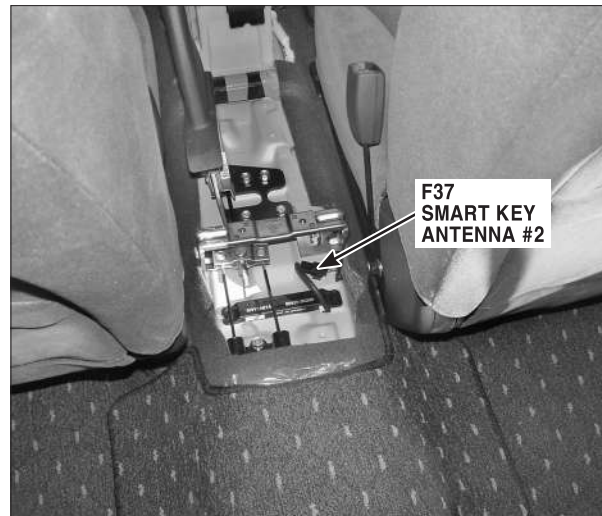
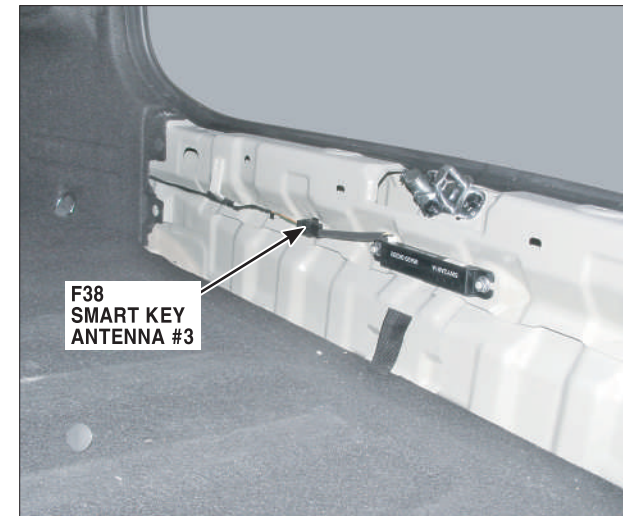

PHOTO.42





# COMPONENT LOCATIONS

## Component Locations(8)

CL-8

PHOTO.43

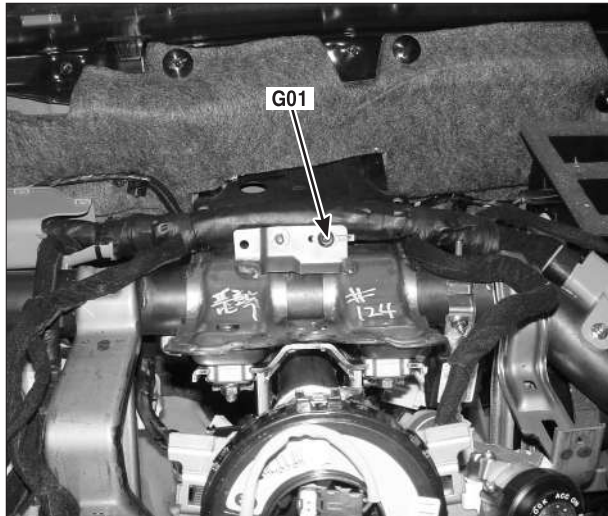

PHOTO.44

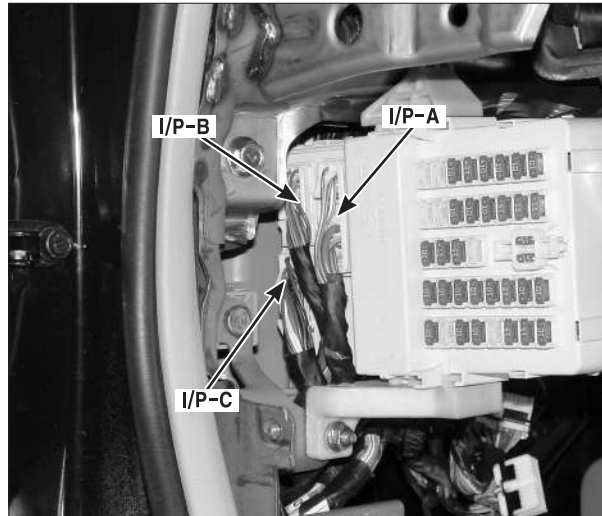

PHOTO.45

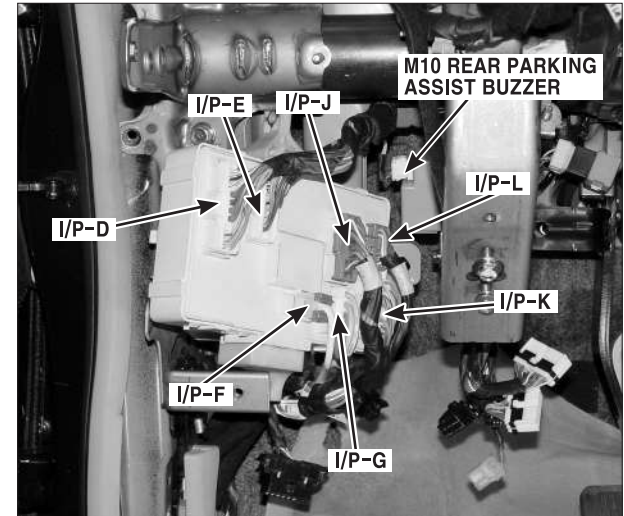

PHOTO.46

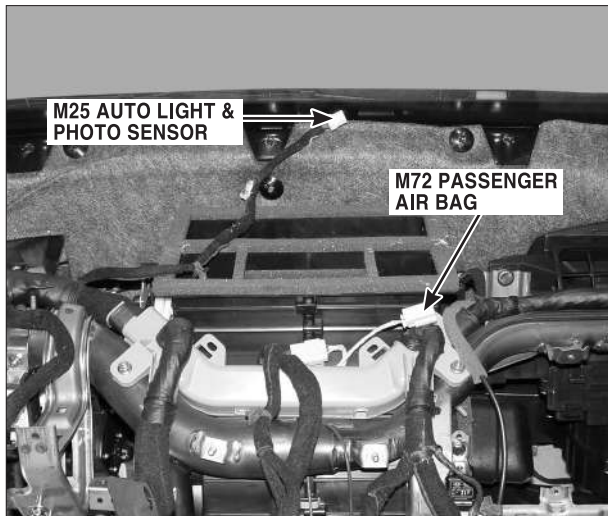

PHOTO.47

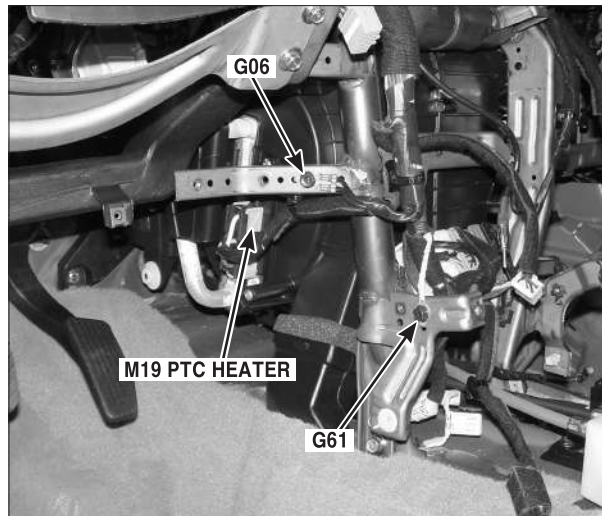
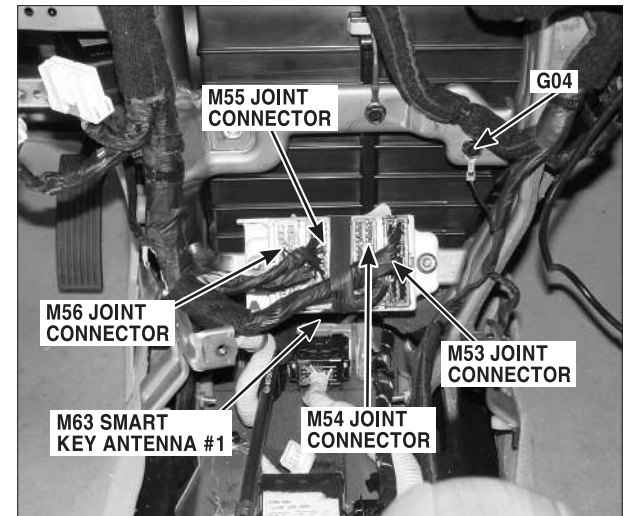

PHOTO.48





# COMPONENT LOCATIONS

## Component Locations(9)

CL-9

PHOTO.49

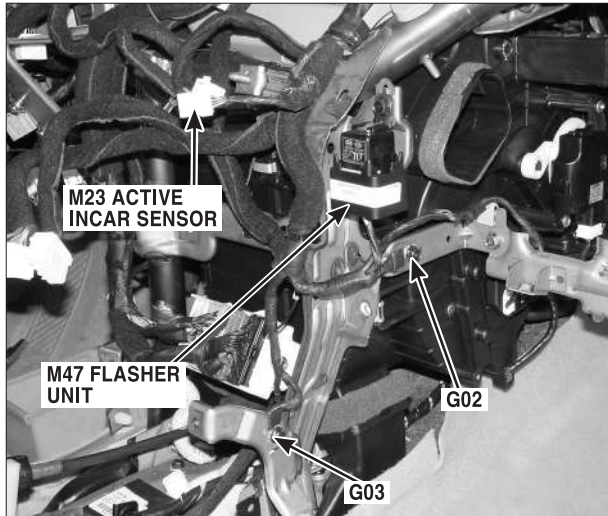

PHOTO.50

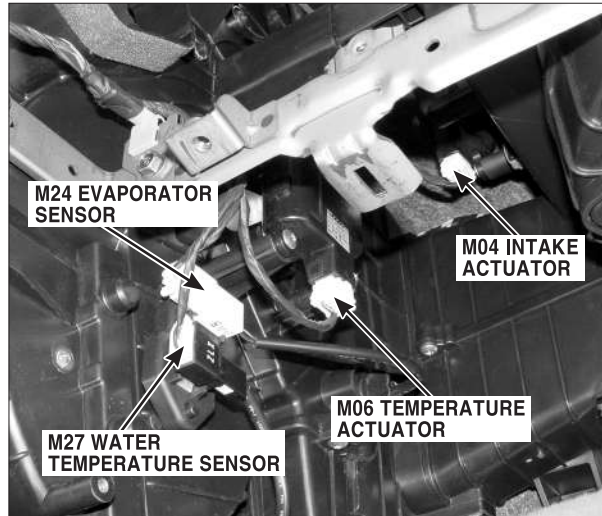

PHOTO.51

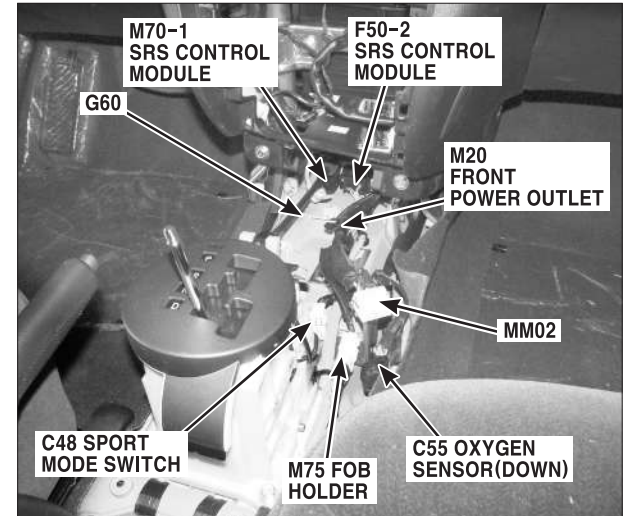

PHOTO.52

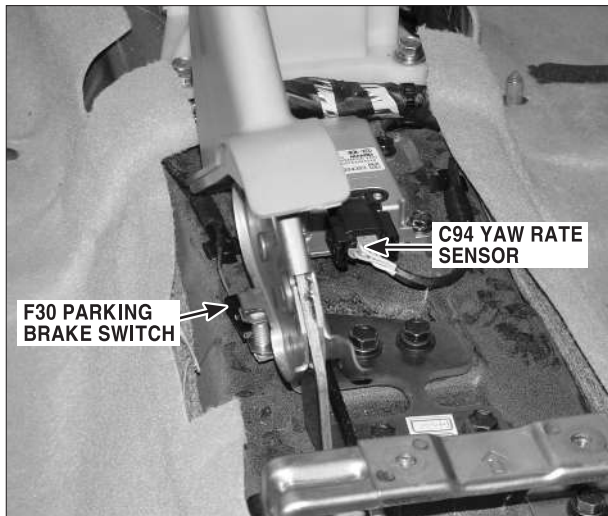

PHOTO.53

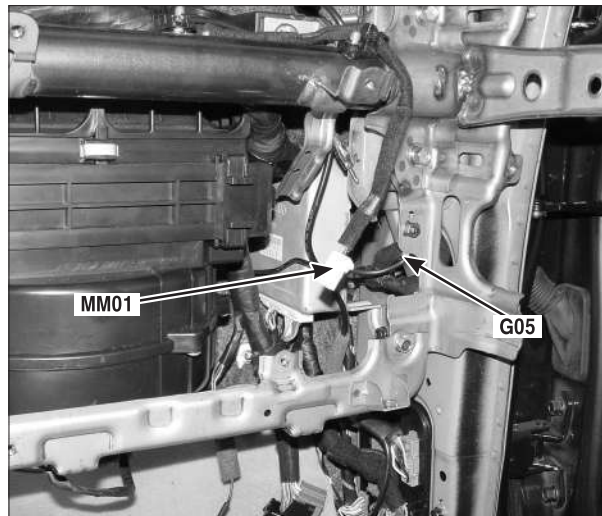
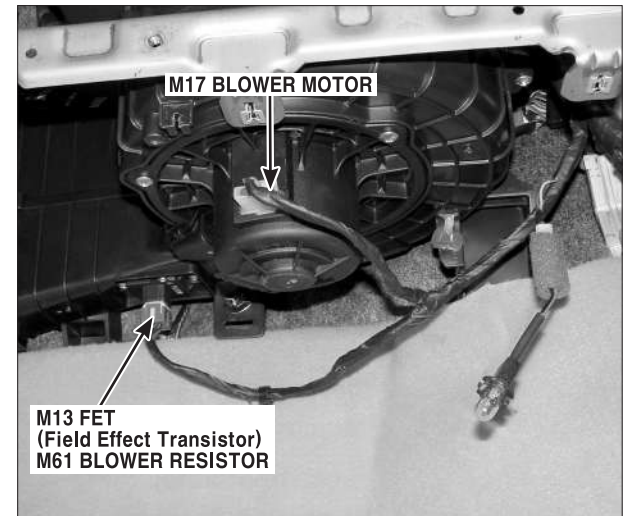

PHOTO.54



# COMPONENT LOCATIONS

## Component Locations(10)

CL-10

PHOTO.55

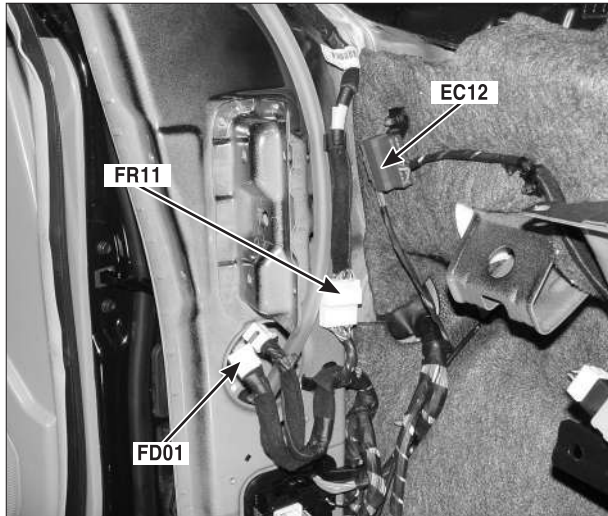

PHOTO.56

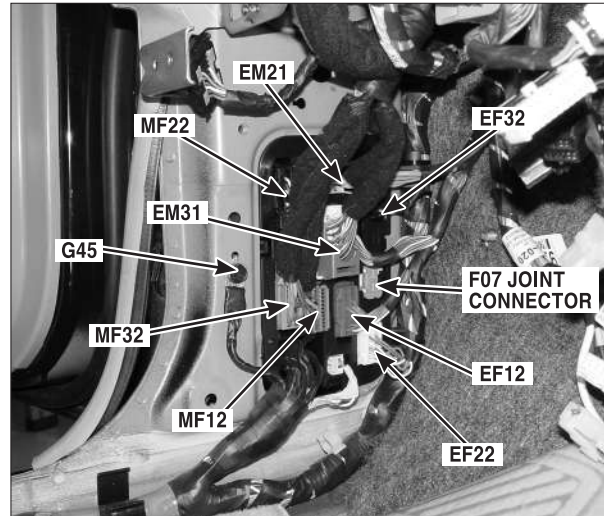

PHOTO.57

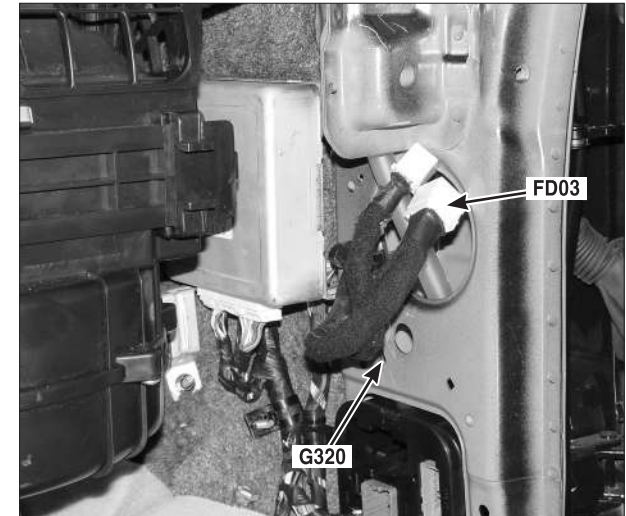

PHOTO.58

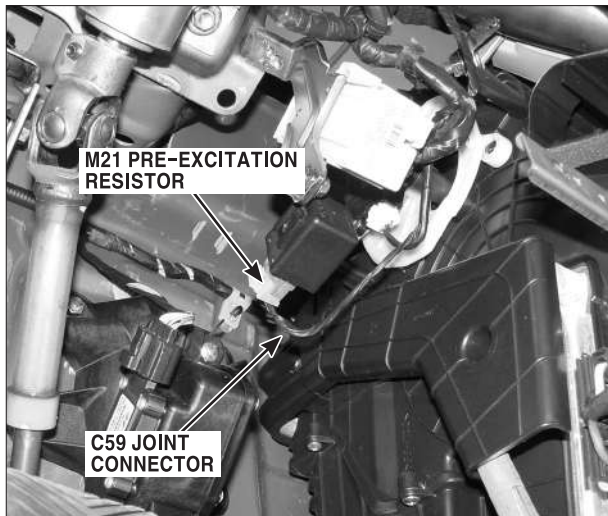

PHOTO.59

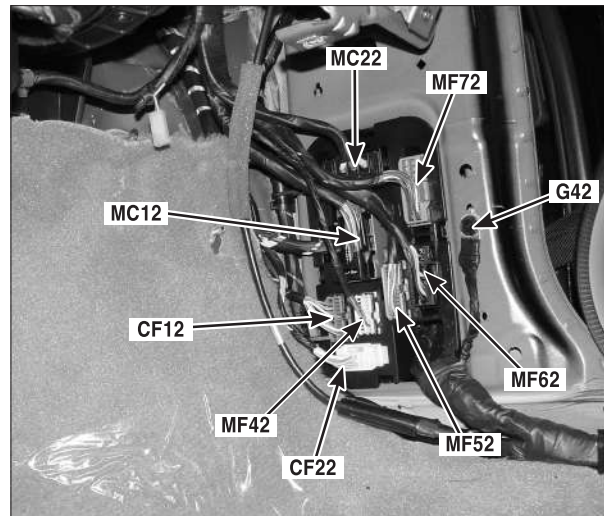

PHOTO.60





# COMPONENT LOCATIONS

## Component Locations(11)

CL-11

PHOTO.61

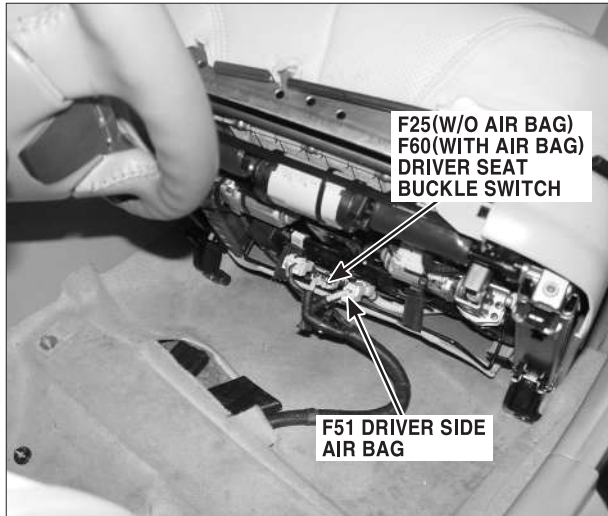

PHOTO.62

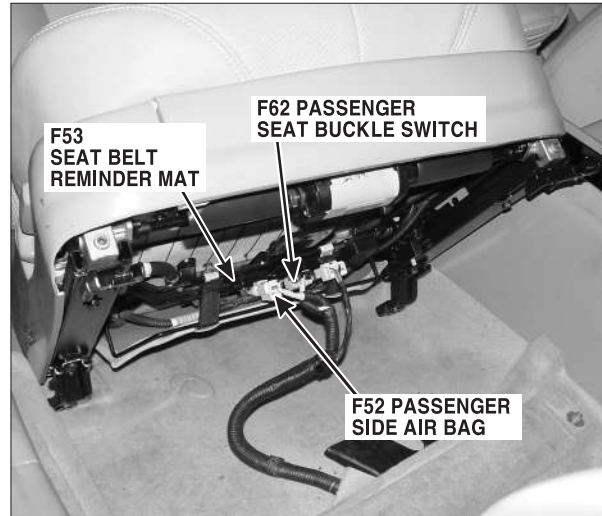

PHOTO.63

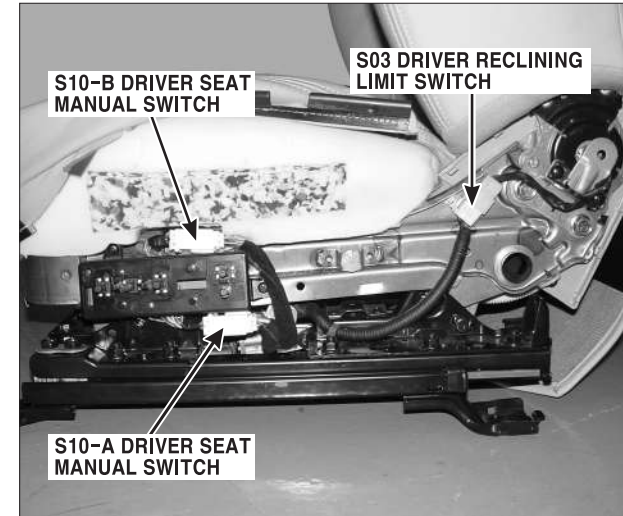

PHOTO.64

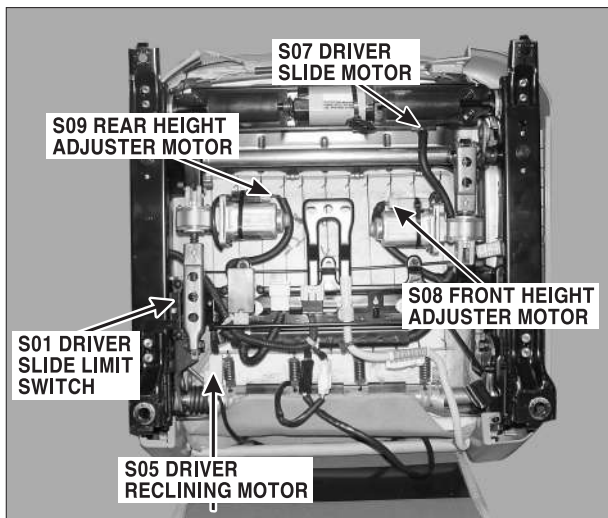

PHOTO.65

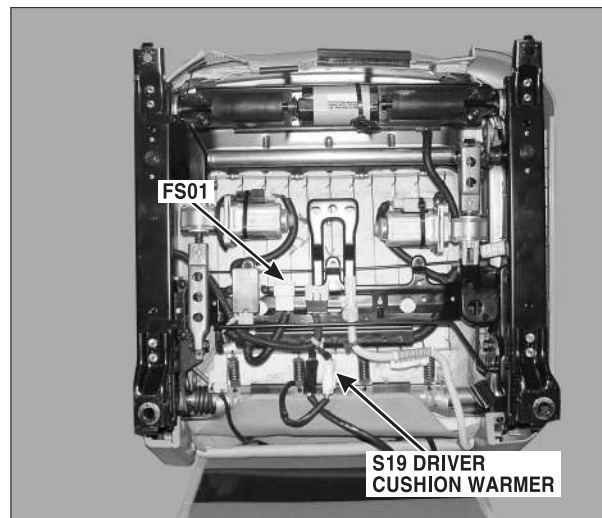
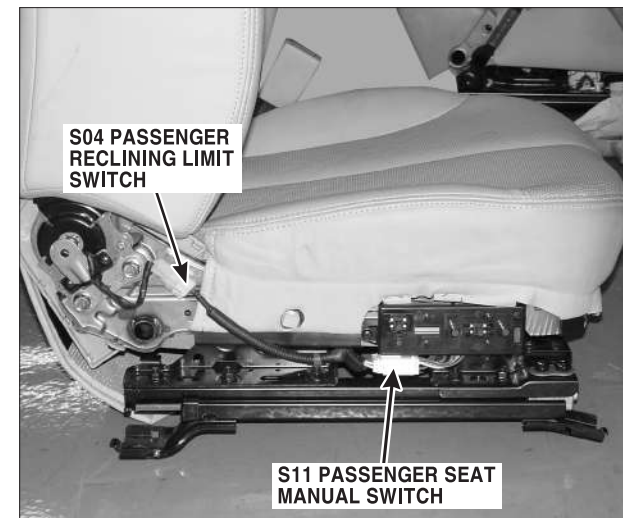

PHOTO.66



# COMPONENT LOCATIONS

## Component Locations(12)

CL-12

PHOTO.67

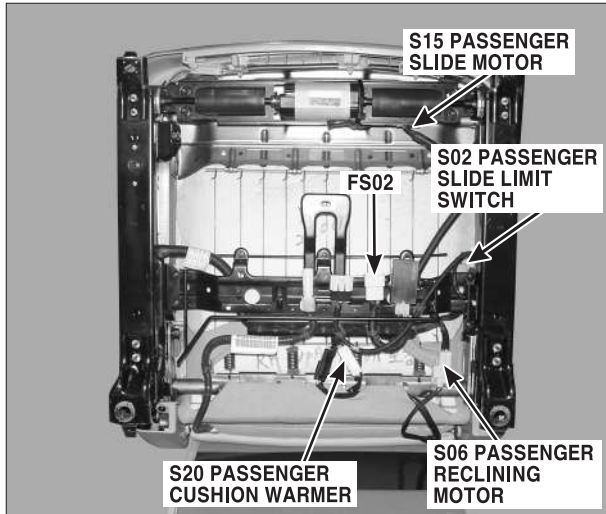

PHOTO.68

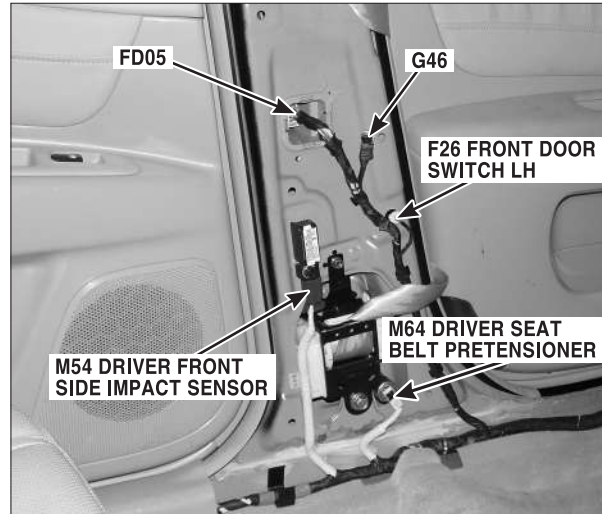

PHOTO.69

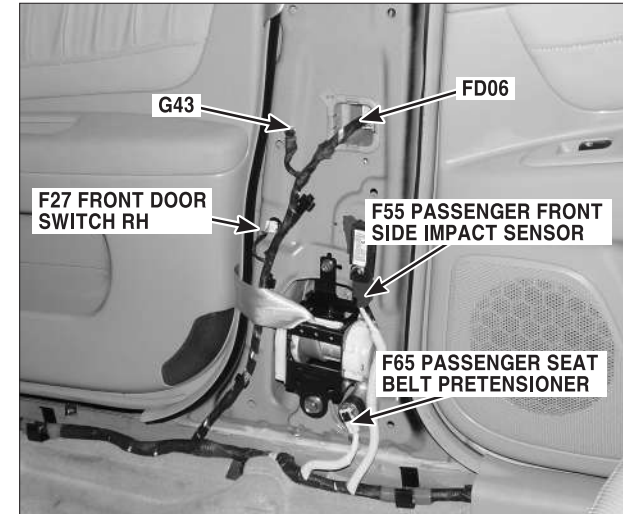

PHOTO.70

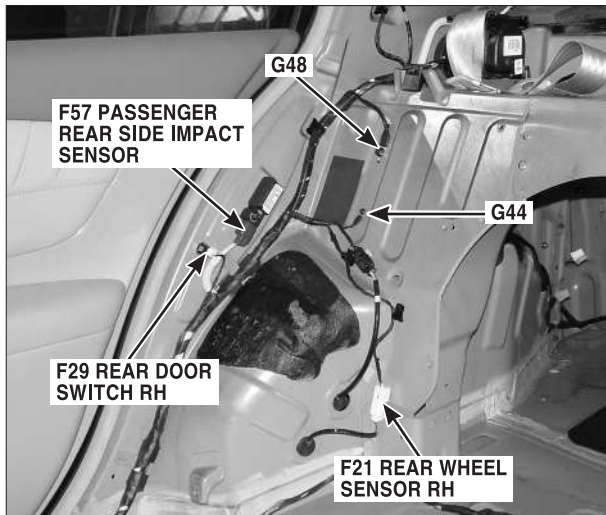

PHOTO.71

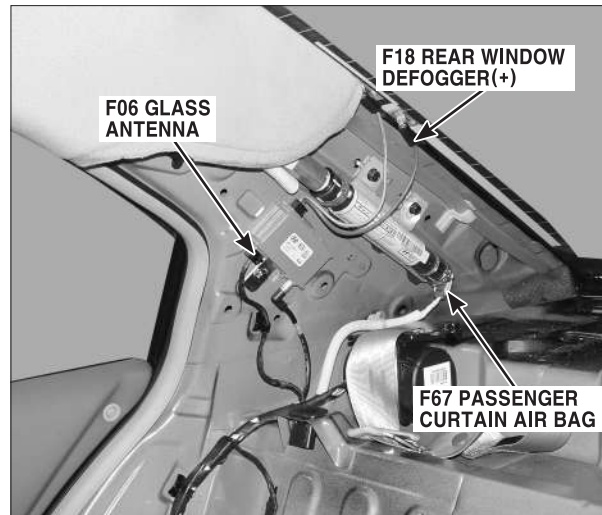
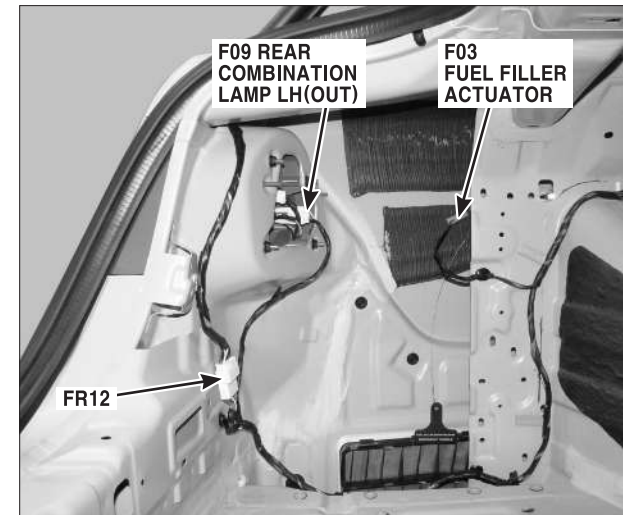

PHOTO.72





# COMPONENT LOCATIONS

## Component Locations(13)

CL-13

PHOTO.73

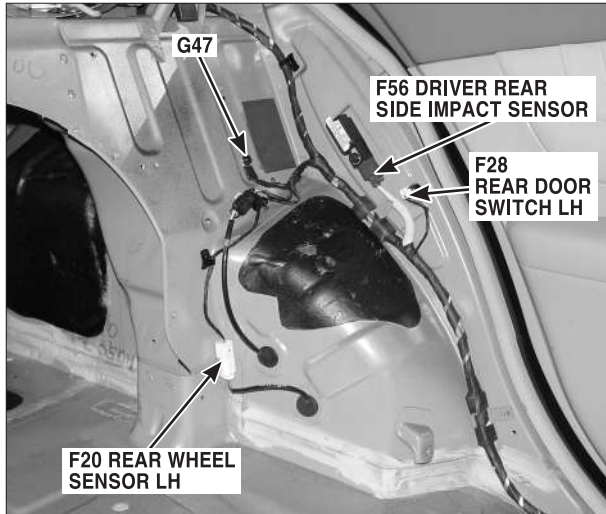

PHOTO.74

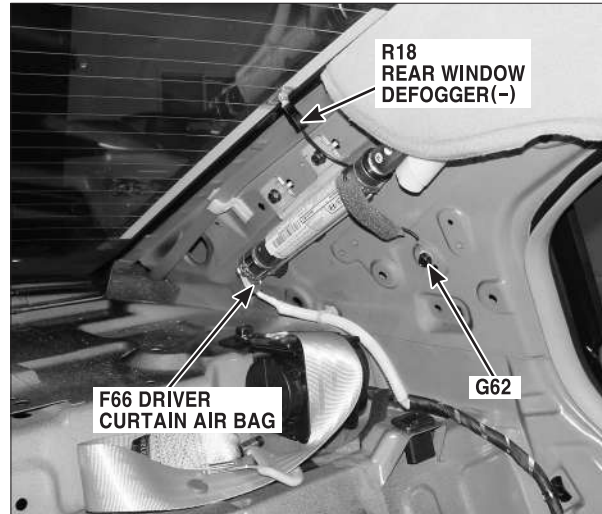

PHOTO.75

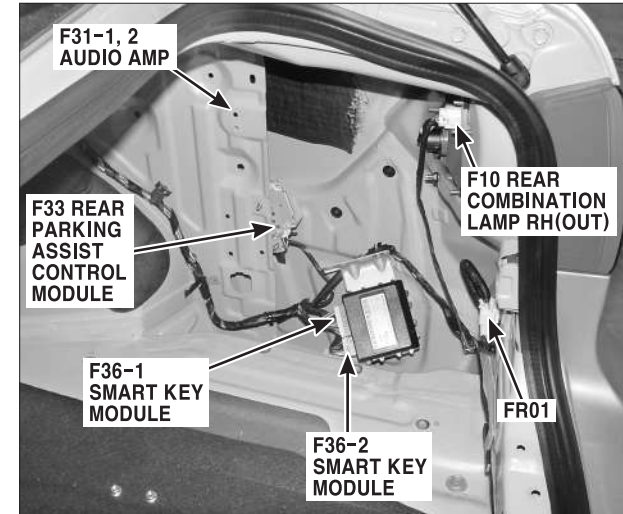

PHOTO.76

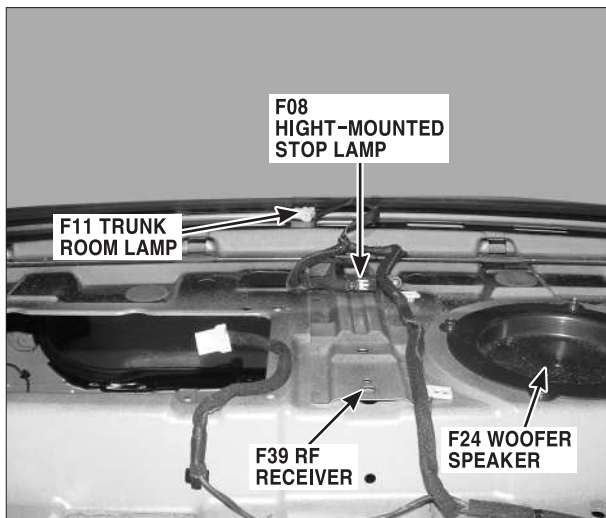

PHOTO.77

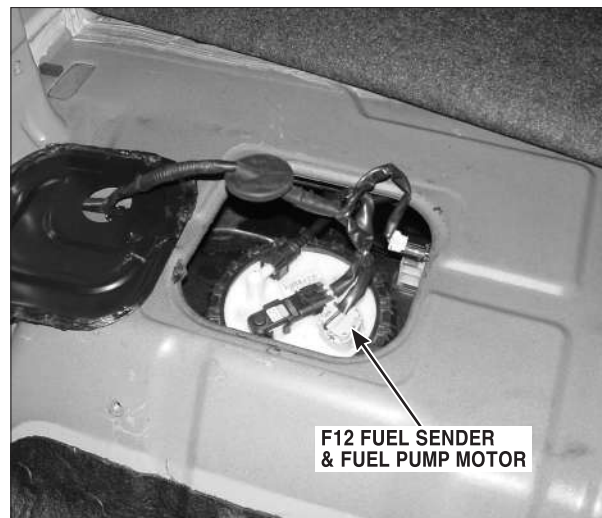
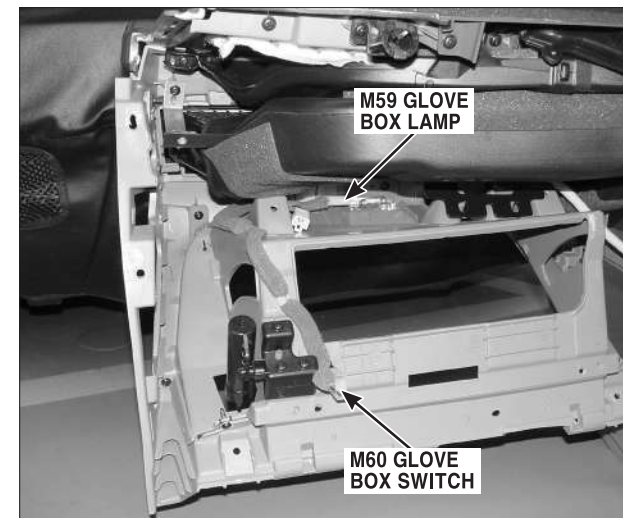

PHOTO.78



# COMPONENT LOCATIONS

## Component Locations(14)

CL-14

PHOTO.79

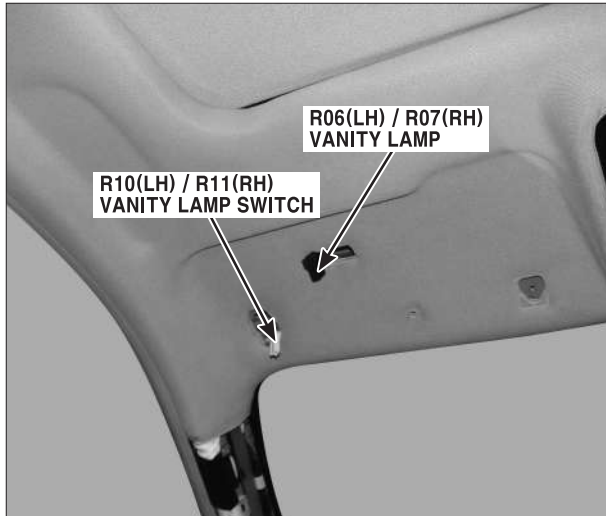

PHOTO.80

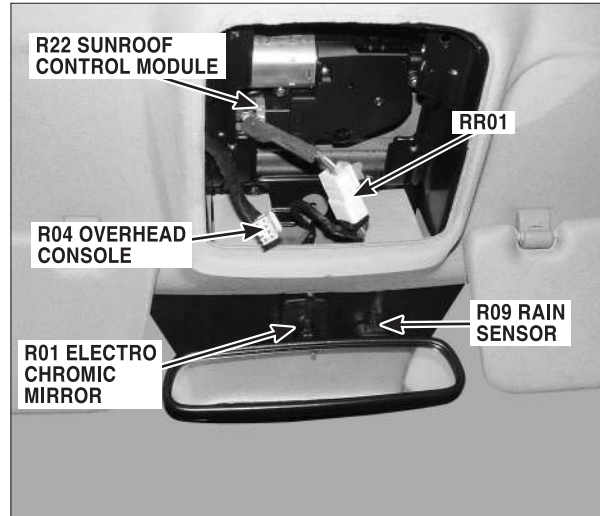

PHOTO.81



PHOTO.82



PHOTO.83

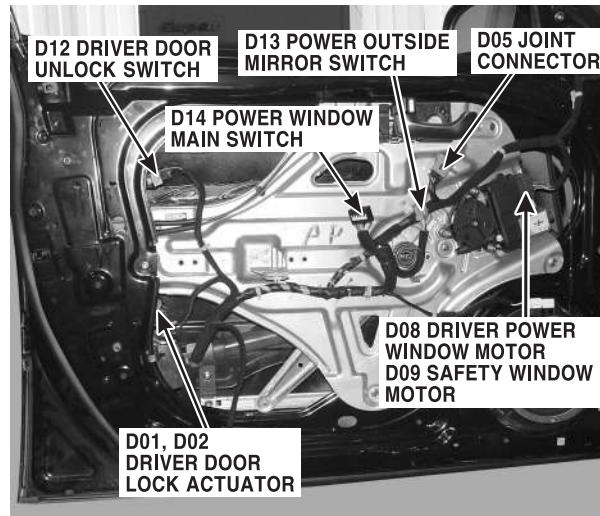
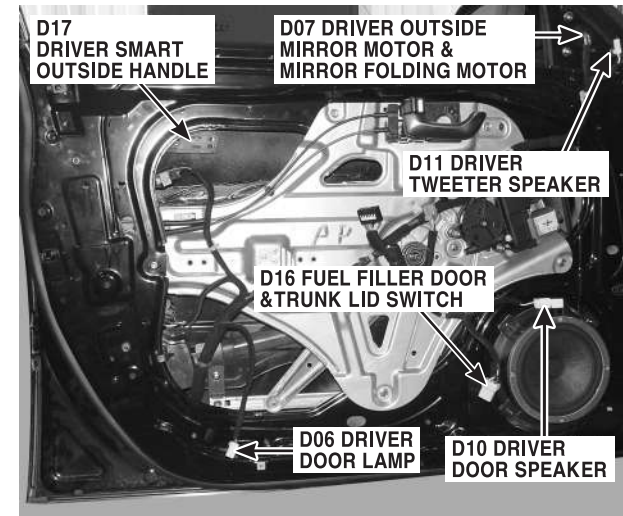

PHOTO.84





# COMPONENT LOCATIONS

## Component Locations(15)

CL-15

PHOTO.85

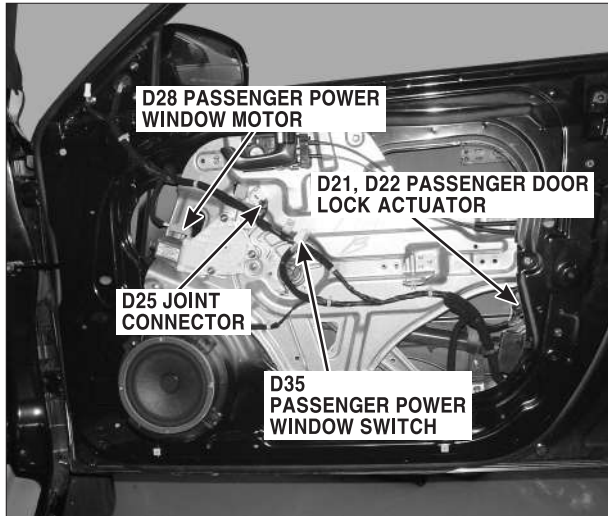

PHOTO.86

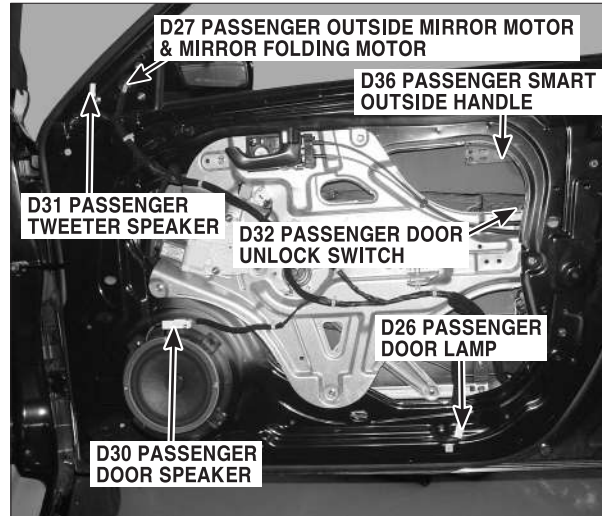

PHOTO.87

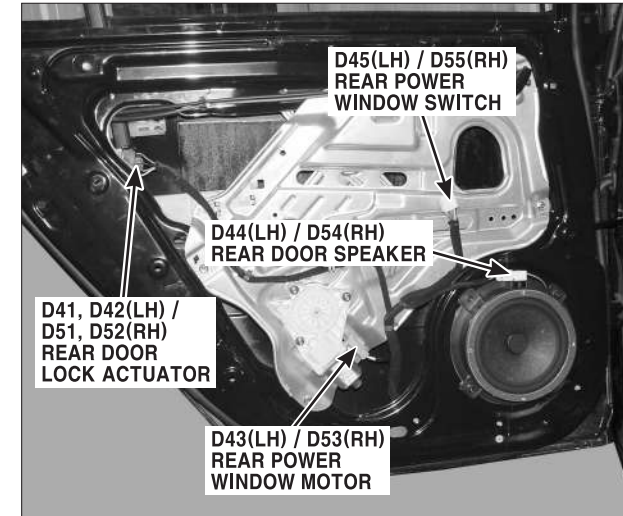

PHOTO.88

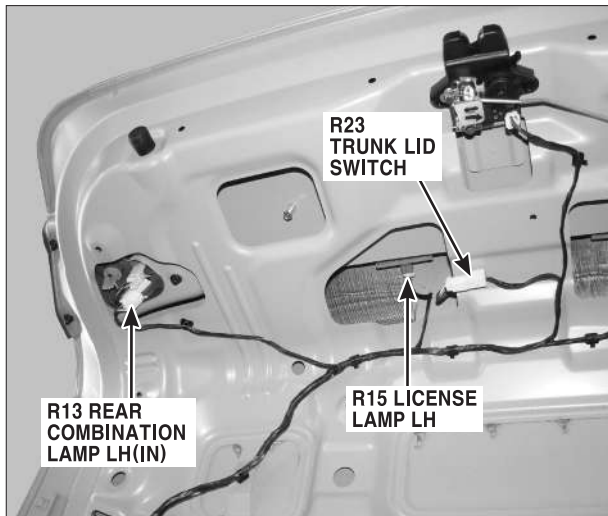

PHOTO.89

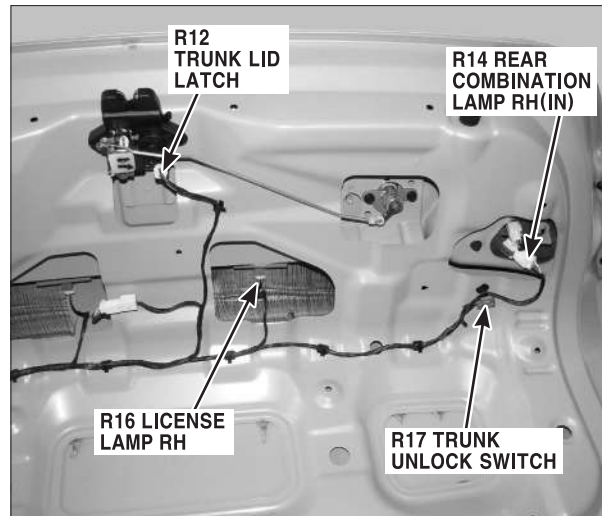
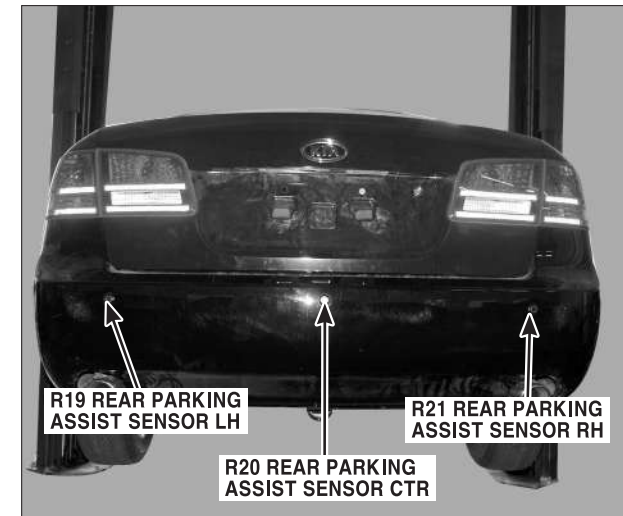

PHOTO.90



# COMPONENT LOCATIONS

## Component Locations(16)

CL-16

PHOTO.91

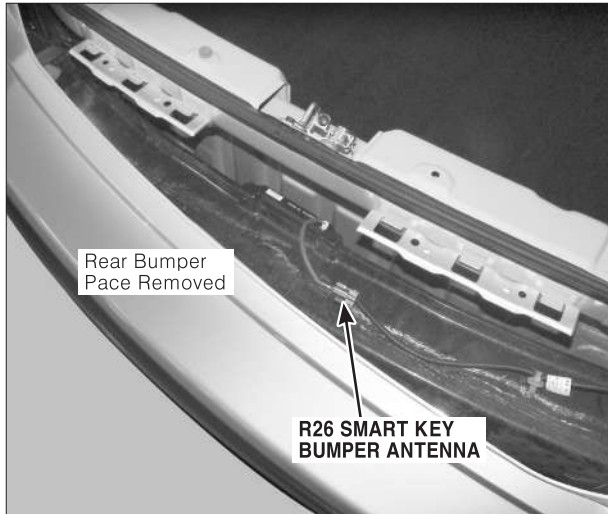

PHOTO.92

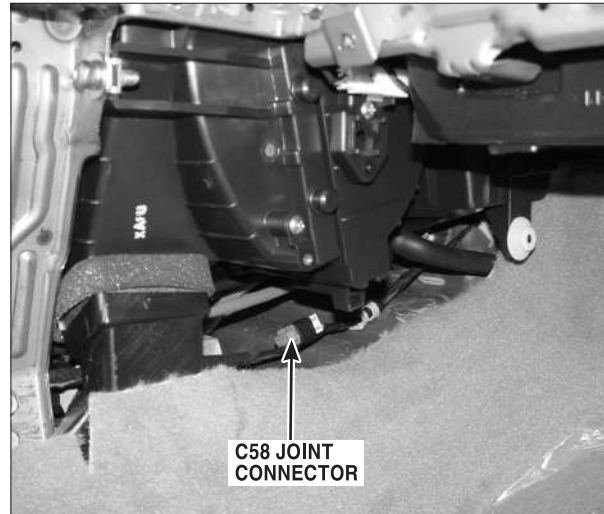

PHOTO.93

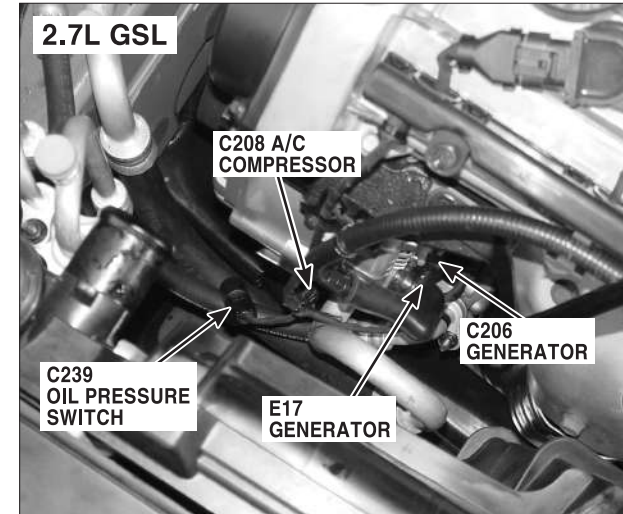

PHOTO.94

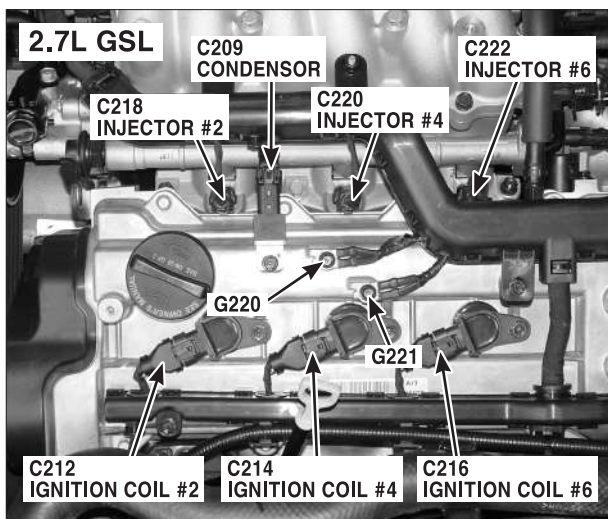

PHOTO.95

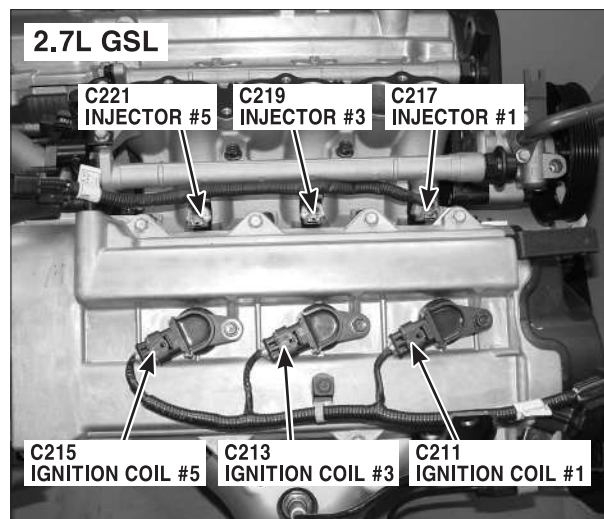
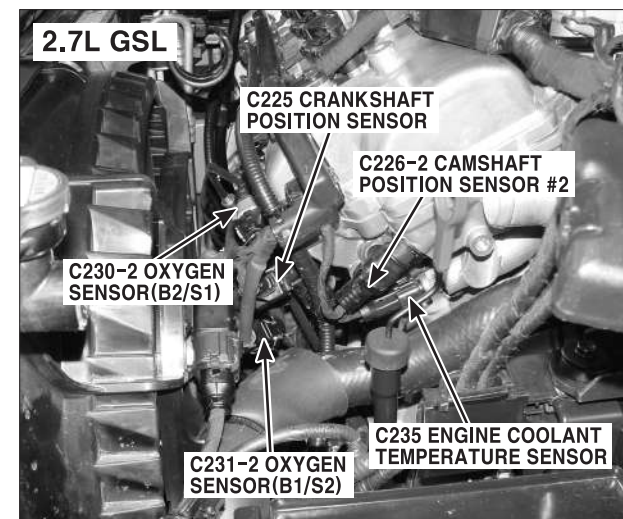

PHOTO.96





# COMPONENT LOCATIONS

## Component Locations(17)

CL-17

PHOTO.97

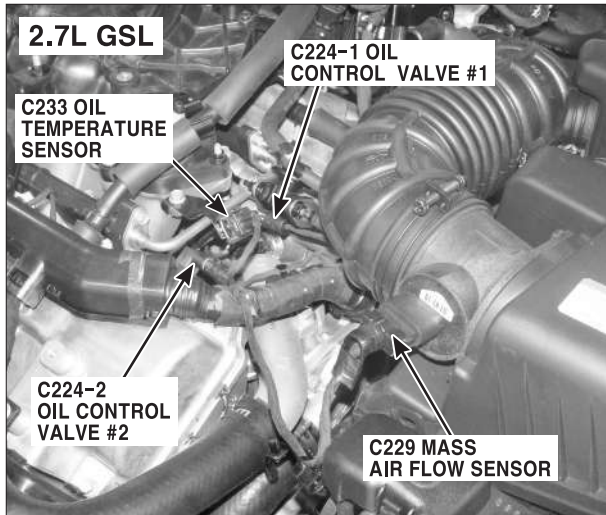

PHOTO.98

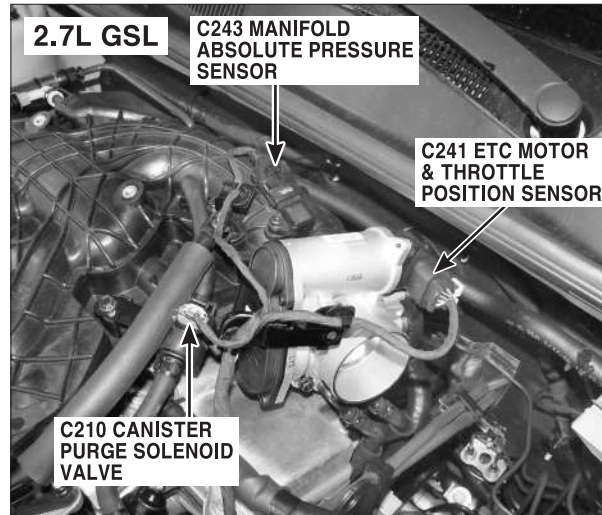

PHOTO.99

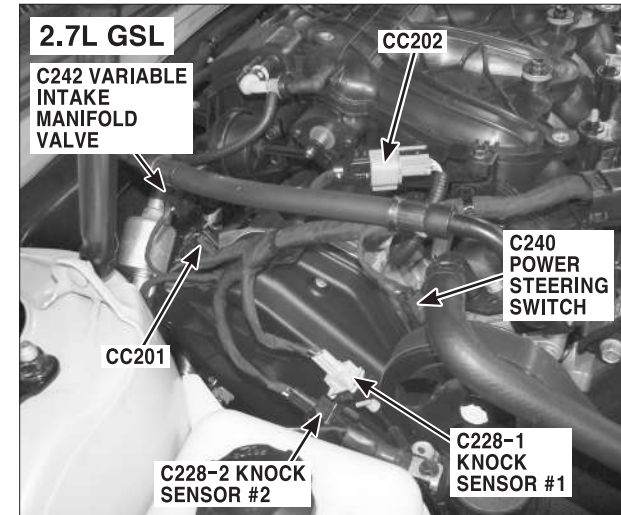

PHOTO.100

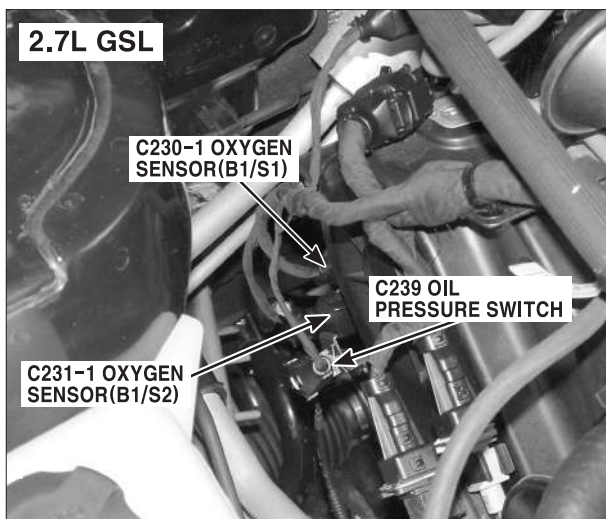

PHOTO.101

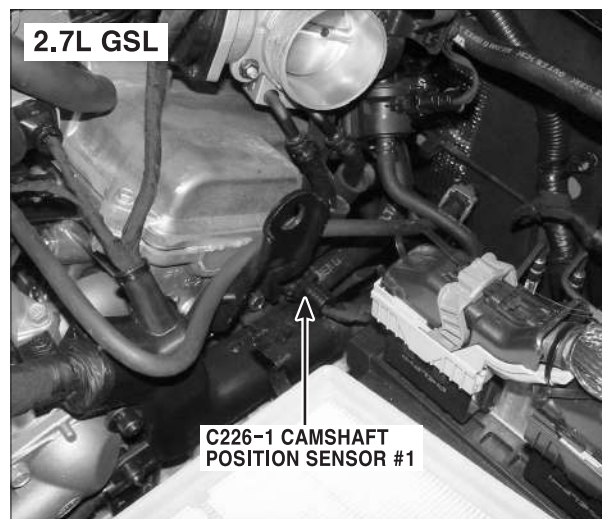
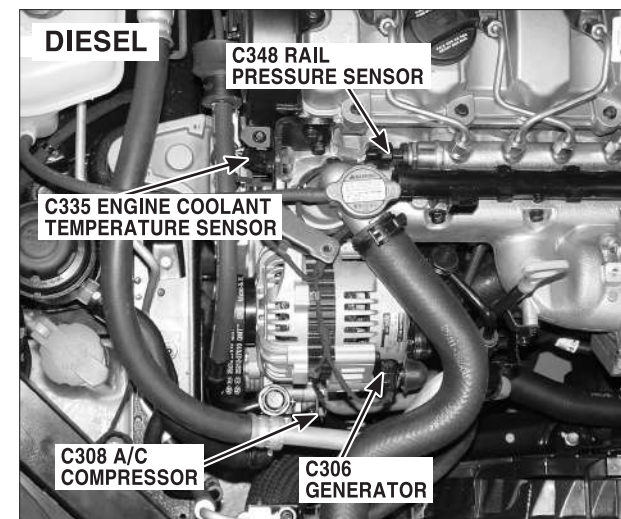

PHOTO.102





# COMPONENT LOCATIONS

## Component Locations(18)

CL-18

PHOTO.103

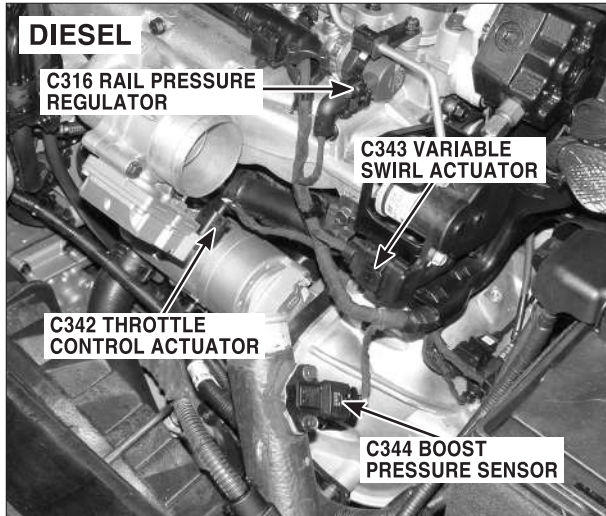

PHOTO.104

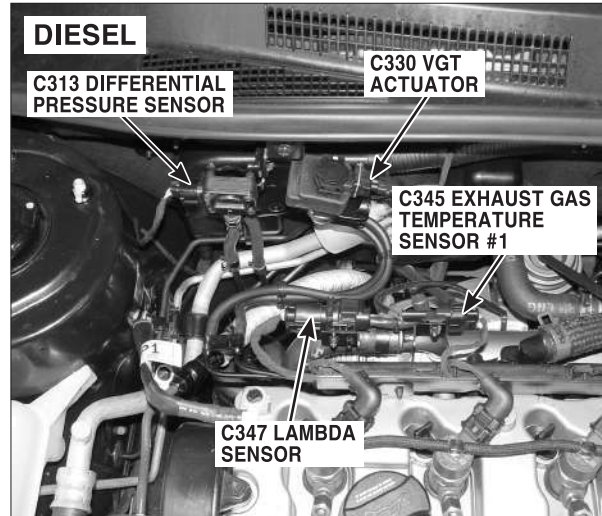

PHOTO.105

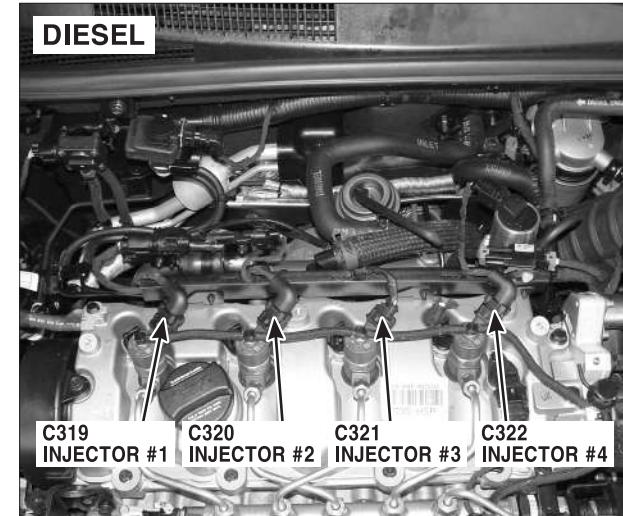

PHOTO.106

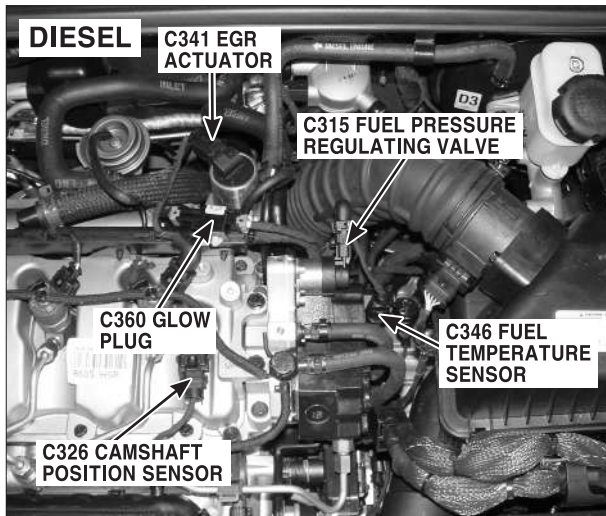

PHOTO.107

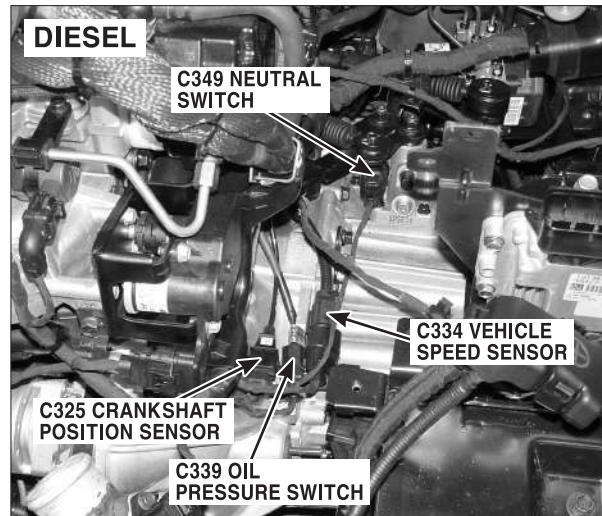

PHOTO.108



# COMPONENT LOCATIONS

## Component Locations(19)

CL-19

PHOTO.109

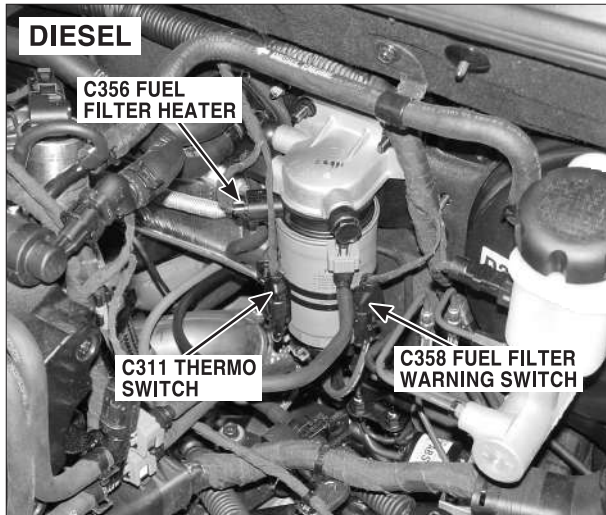

PHOTO.110

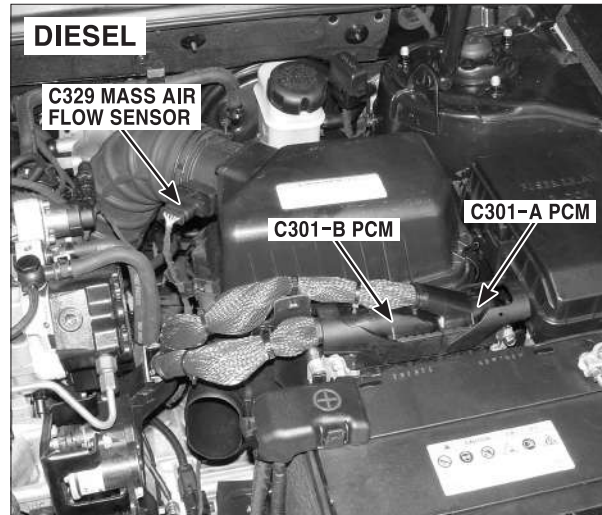

PHOTO.111

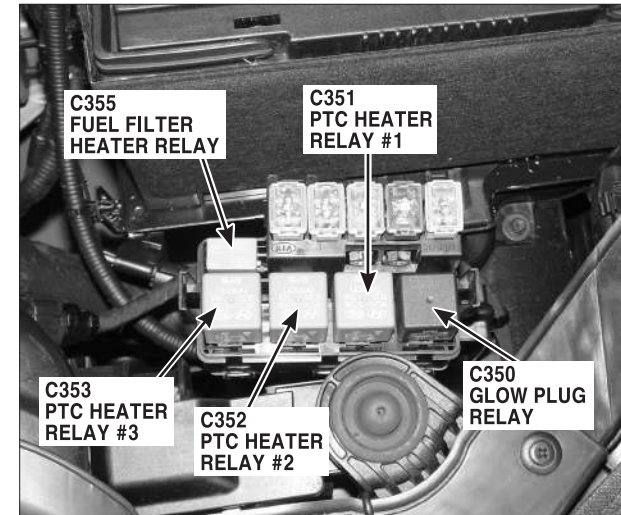

PHOTO.112



PHOTO.113

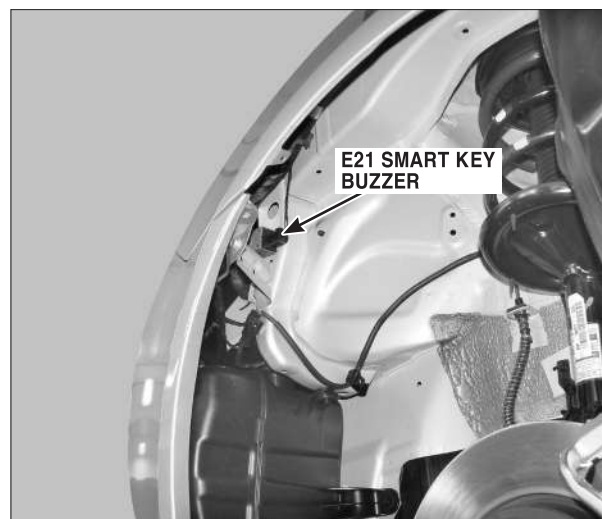

PHOTO.114





# COMPONENT LOCATIONS

## Component Locations(20)

CL-20

PHOTO.115



PHOTO.116

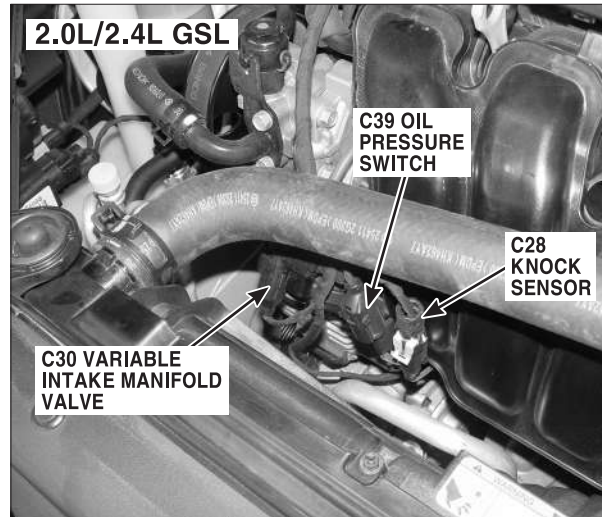

PHOTO.117

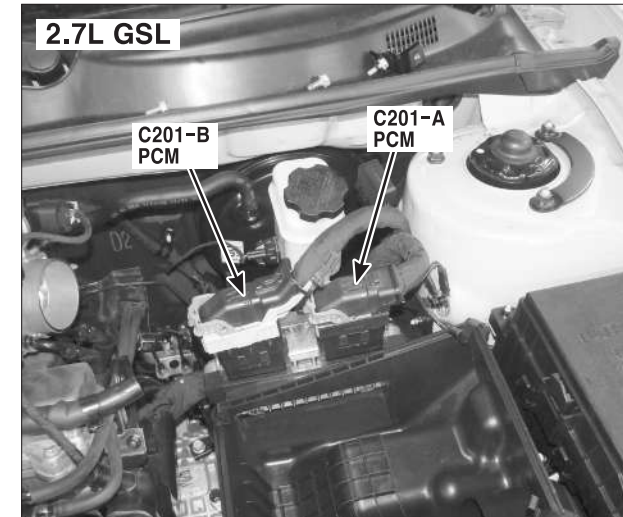

PHOTO.118

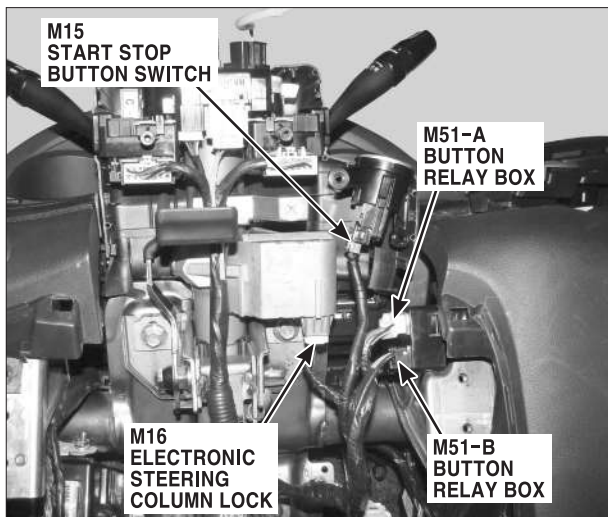
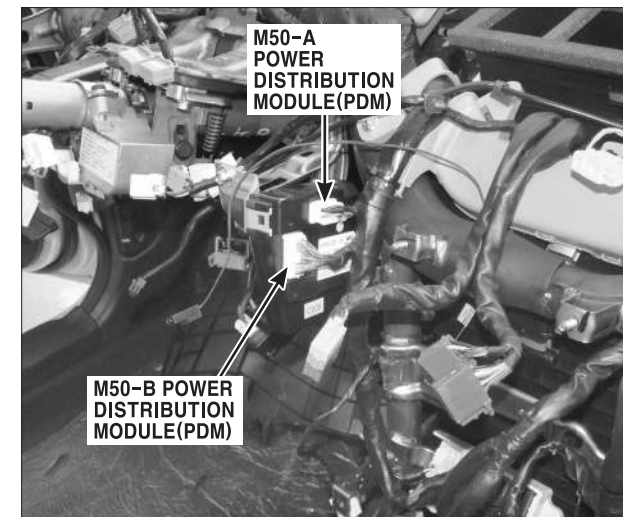

PHOTO.119



PHOTO.120



## COMPONENT LOCATIONS

### Component Locations(21)

CL-21

PHOTO.121



PHOTO.122



# HARNESS CONNECTOR

E3AAB564

## Harness Connector (1)

CC-1

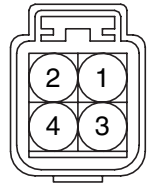

KUM\_NMWP\_04F\_B

CC201

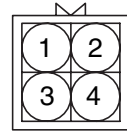

KUM\_NMWP\_04M\_B

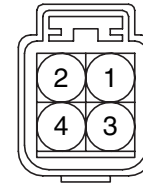

KUM\_NMWP\_04F\_GR

CC202

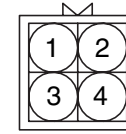

KUM\_NMWP\_04M\_GR



AMP\_8MM\_01F\_B

CC301

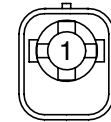

AMP\_8MM\_01M\_B

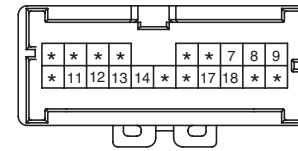

AMP\_040III\_20M\_BR

CF12

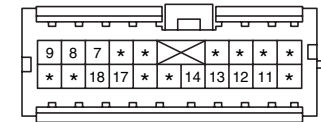

AMP\_040III\_20F\_BR

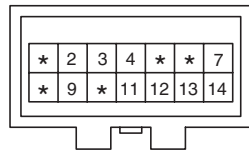

AMP\_090III\_14M\_W

CF22

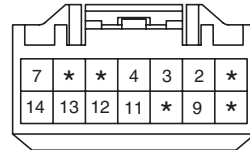

AMP\_090III\_14F\_W

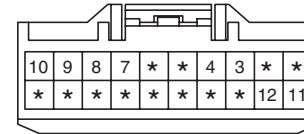

AMP\_090III\_20F\_L

EC12

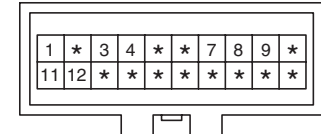

AMP\_090III\_20M\_L



KUM\_NMWP\_01F\_B

EE01

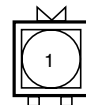

CR01M002



AMP\_EJWP\_16F\_B

EE02

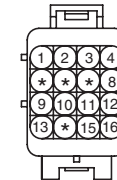

AMP\_EJWP\_16M\_B

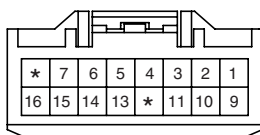

AMP\_090III\_16F\_R

EF12

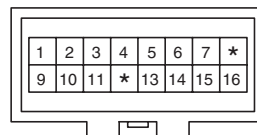

AMP\_090III\_16M\_R

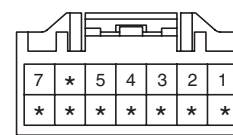

AMP\_090III\_14F\_W

EF22

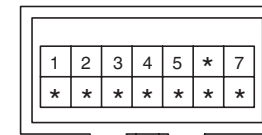

AMP\_090III\_14M\_W

# HARNESS CONNECTOR

## Harness Connector (2)

CC-2

EF32

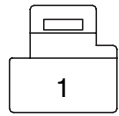

KET\_58L\_01F\_W

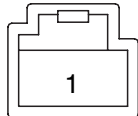

KET\_58L\_01M\_W

EM21

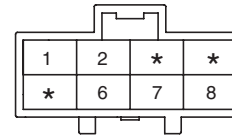

KET\_250DL\_08M\_W

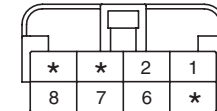

KET\_250DL\_08F\_W

EM31

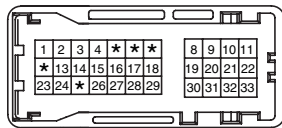

KET\_LIF040\_9\_33M\_W

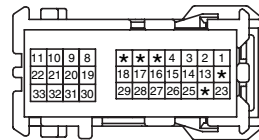

KET\_LIF0409\_33F\_W

EM41

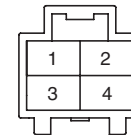

KET\_250DL\_04M\_W

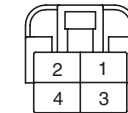

KET\_250DL\_04F\_W

FD01

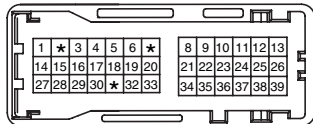

KET\_LIF0409\_39M\_W\_DR

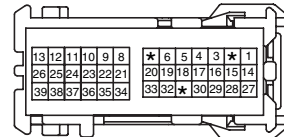

KET\_LIF0409\_39F\_W\_DR

FD03

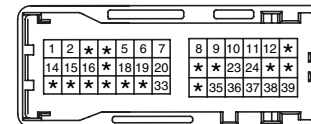

KET\_LIF0409\_39M\_W\_DR

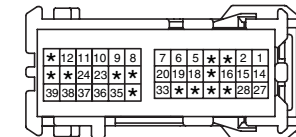

KET\_LIF0409\_39F\_W\_DR

FD05

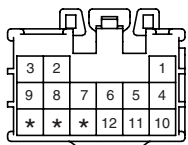

KET\_090III\_15F\_W

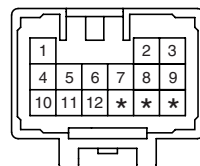

KET\_090III\_15M\_W

FD06

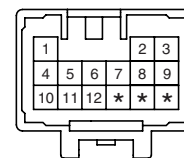

KET\_090III\_15M\_W

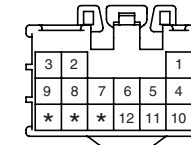

KET\_090III\_15F\_W

FR01

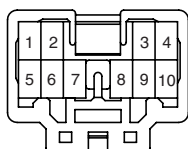

KET\_050\_10M\_W

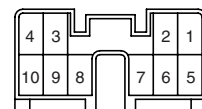

KET\_050\_10F\_W

FR11

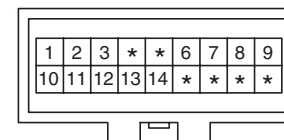

AMP\_090III\_18M\_W

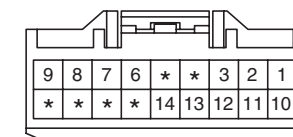

AMP\_090III\_18F\_W

# HARNESS CONNECTOR

## Harness Connector (3)

CC-3

### FR12

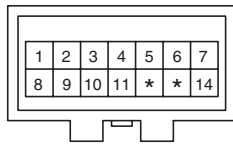

AMP\_090III\_14M\_W

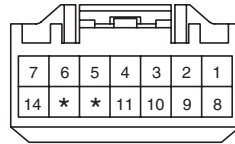

AMP\_090III\_14F\_W

### FS01

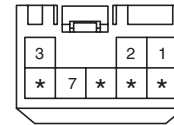

AMP\_090III\_08F\_W

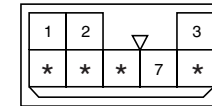

CR08M007

### FS02

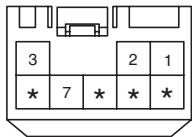

AMP\_090III\_08F\_W

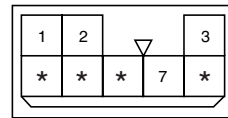

CR08M007

### MC12

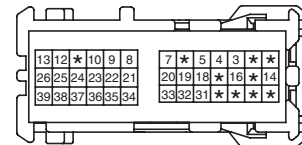

KET\_LIF0409\_39F\_L

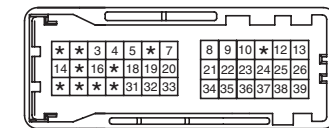

KET\_LIF0409\_39M\_L

### MC22

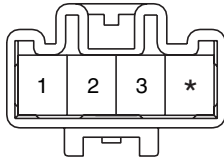

KET\_312II\_04M\_B

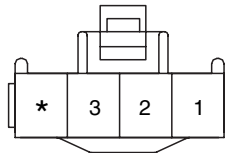

KET\_312II\_04F\_B

### MF12

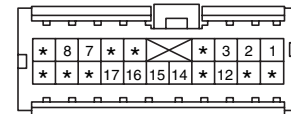

AMP\_040III\_20F\_BR

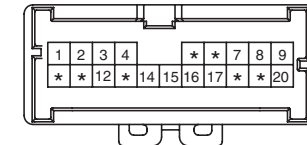

AMP\_040III\_20M\_BR

### MF22

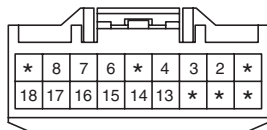

AMP\_090III\_18F\_B

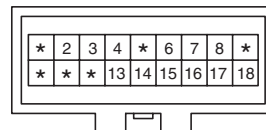

AMP\_090III\_18M\_B

### MF32

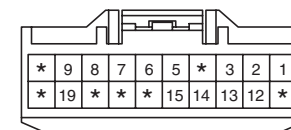

AMP\_090III\_20F\_L

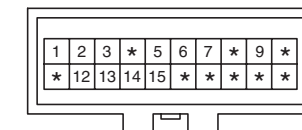

AMP\_090III\_20M\_L

### MF42

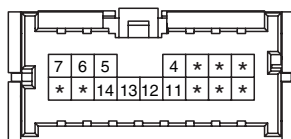

AMP\_040III\_16F\_W

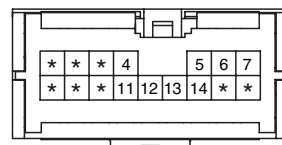

AMP\_040III\_16M\_W

### MF52

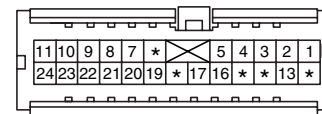

AMP\_040III\_24F\_GR

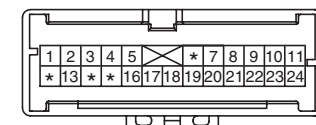

AMP\_040III\_24M\_GR



# HARNESS CONNECTOR

## Harness Connector (4)

CC-4

### MF62

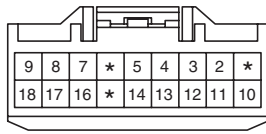

AMP\_090III\_18F\_B

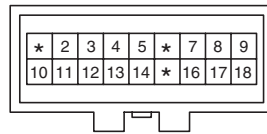

AMP\_090III\_18M\_B

### MF72

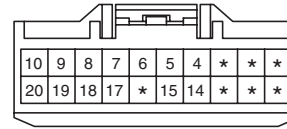

AMP\_090III\_20F\_L

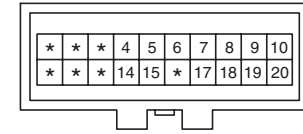

AMP\_090III\_20M\_L

### MF82

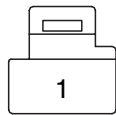

KET\_58L\_01F\_W

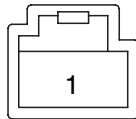

KET\_58L\_01M\_W

### MM01

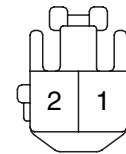

AMP\_090III\_02F\_W\_L

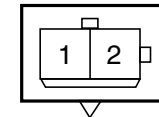

CR02M020

### MM02

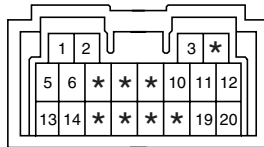

KET\_MG62041

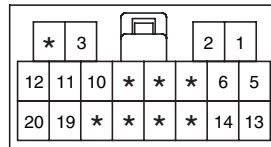

KET\_070-1\_20F\_W\_3

### RR01

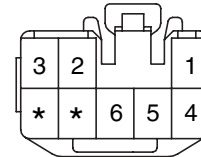

KET\_090II\_08F\_B

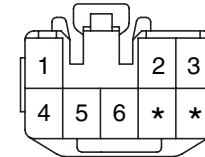

KET\_090II\_08M\_B

E/R Junction Box (1)

CC-5

JC01(2.0L/2.4L)

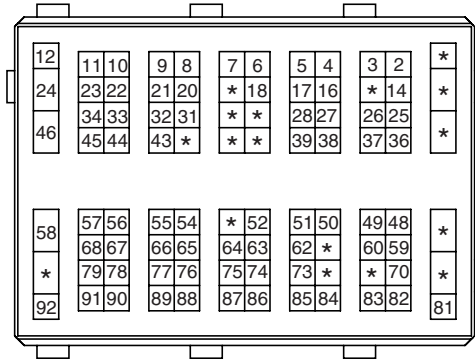

AMP\_MULBOX\_92F\_B

JC01(2.7L)

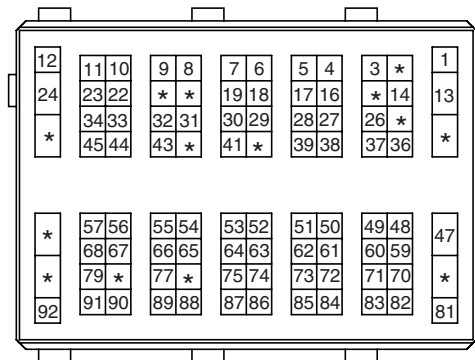

AMP\_MULBOX\_92F\_B

JC01(DSL)

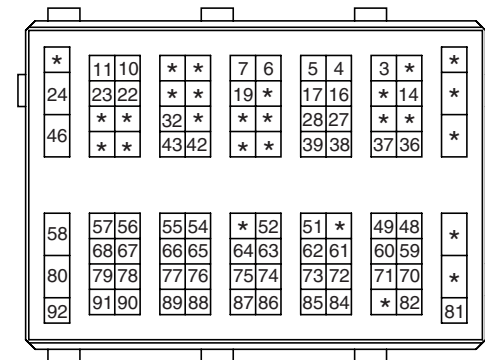

AMP\_MULBOX\_92F\_B

JC02

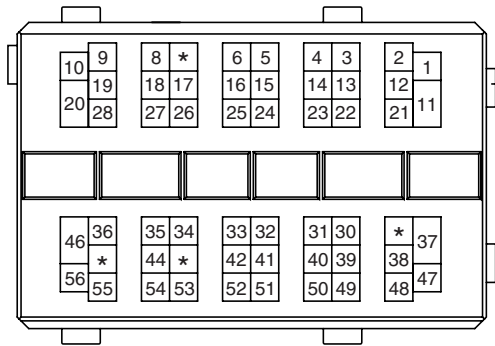

AMP\_MULBOX\_56F\_B

JE01

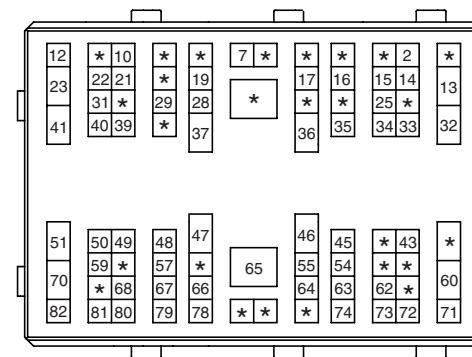

AMP\_MULBOX\_82F\_B

I/P Junction Box (1)				CC-6
<p style="text-align: center;"><b>I/P-A</b></p> <p style="text-align: center;">AMP_0925_18F_W</p>	<p style="text-align: center;"><b>I/P-B</b></p> <p style="text-align: center;">AMP_090III_18F_W</p>	<p style="text-align: center;"><b>I/P-C</b></p> <p style="text-align: center;">AMP_0925_16F_W</p>	<p style="text-align: center;"><b>I/P-D</b></p> <p style="text-align: center;">AMP_0925_20F_W</p>	
<p style="text-align: center;"><b>I/P-E</b></p> <p style="text-align: center;">AMP_090III_20F_W</p>	<p style="text-align: center;"><b>I/P-F(LHD) I/P-FR(RHD)</b></p> <p style="text-align: center;">KET_58L_01F_W</p>	<p style="text-align: center;"><b>I/P-G(LHD) I/P-GR(RHD)</b></p> <p style="text-align: center;">AMP_250_04F_W_SPT</p>	<p style="text-align: center;"><b>I/P-J</b></p> <p style="text-align: center;">AMP_0925_14F_BR</p>	
<p style="text-align: center;"><b>I/P-K(LHD)</b></p> <p style="text-align: center;">AMP_0925_12F_W</p>	<p style="text-align: center;"><b>I/P-KR(RHD)</b></p> <p style="text-align: center;">AMP_0925_12F_W</p>	<p style="text-align: center;"><b>I/P-L</b></p> <p style="text-align: center;">AMP_090III_12F_BR</p>	<p style="text-align: center;"><b>BLANK</b></p>	

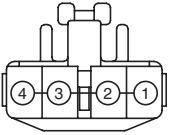
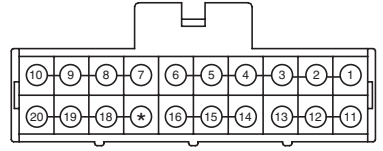
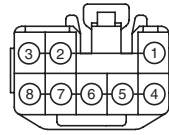
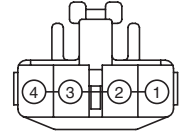
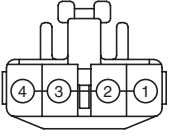
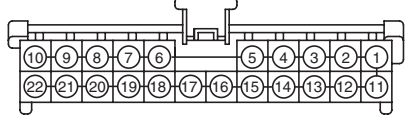
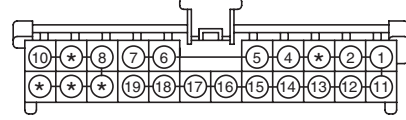
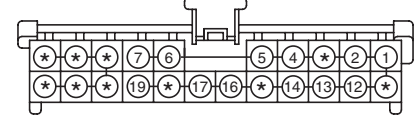
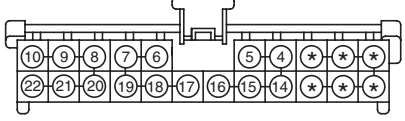
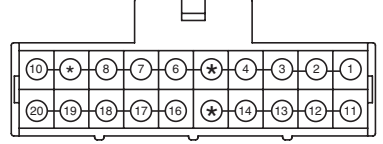
Joint Connector (1)			CC-7
<p><b>C58</b></p>  <p>KET_090II_04F_JCH</p>	<p><b>C59</b></p>  <p>KET_090II_20F_B_JCH</p>	<p><b>D05</b></p>  <p>AMP_090III_08F_B</p>	<p><b>D25</b></p>  <p>KET_090III_04F_B</p>
<p><b>F07</b></p>  <p>AMP_090II_04F_W</p>	<p><b>M53</b></p>  <p>KUM_AR_22F_B</p>	<p><b>M54</b></p>  <p>KUM_AR_22F_L</p>	<p><b>M55</b></p>  <p>KUM_AR_22F_O</p>
<p><b>M56</b></p>  <p>KUM_AR_22F_W</p>	<p><b>R03</b></p>  <p>KET_090II_20F_B_JCH</p>	<p><b>BLANK</b></p>	<p><b>BLANK</b></p>

Main Harness (1)

HL-1

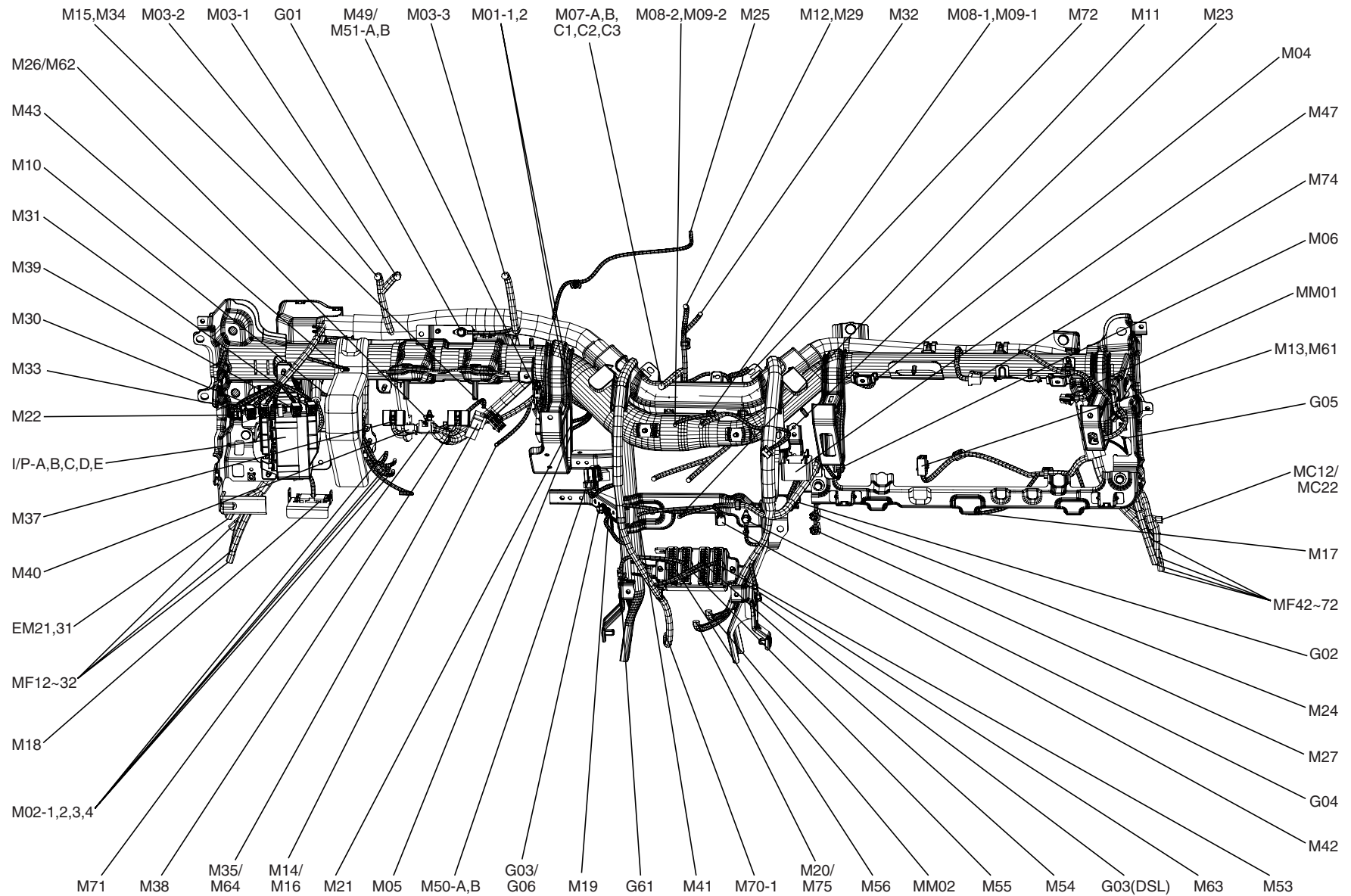

## MAIN HARNESS

### Main Harness (2)

HL-2

#### MAIN HARNESS

M01-1	ICM relay box	M30	ESP switch	I/P-KR	Connection with I/P JUNCTION BOX (RHD)
M01-2	ICM relay box	M31	Windshield defogger switch	MC12	Connection with CONTROL DASH harness
M02-1	BCM	M32	Hazard switch	MC22	Connection with CONTROL DASH harness (DSL)
M02-2	BCM	M33	Head lamp leveling switch	MF12	Connection with FLOOR harness
M02-3	BCM	M34	Ignition switch (W/O Button starting)	MF22	Connection with FLOOR harness
M02-4	BCM	M35	Key illumination switch (W/O Button starting)	MF32	Connection with FLOOR harness
M03-1	Instrument cluster	M37	Multifunction switch (Light,LHD)	MF42	Connection with FLOOR harness
M03-2	Instrument cluster	M37R	Multifunction switch (Light,RHD)	MF52	Connection with FLOOR harness
M03-3	Instrument cluster	M38	Multifunction switch (Wiper,LHD)	MF62	Connection with FLOOR harness
M04	Intake actuator	M38R	Multifunction switch (Wiper,RHD)	MF72	Connection with FLOOR harness
M05	Mode actuator	M39	Rear fog lamp switch	MF82	Connection with FLOOR harness (RHD)
M06	Temperature actuator	M40	Multifunction switch (Remocon switch)	MM01	Connection with GLOVE BOX EXT. harness
M07-A	Audio	M41	Driver seat warmer switch	MM02	Connection with MULTIMEDIA JACK EXT. harness
M07-B	Audio	M42	Passenger seat warmer switch	G01	Ground
M07-C1	Audio	M43	Trip mode switch	G02	Ground
M07-C2	Audio	M47	Flasher unit	G03	Ground
M07-C3	Audio	M49	Immobilizer control module	G04	Ground
M08-1	A/C control module (Auto)	M50-A	Power Distribution Module(PDM)	G05	Ground
M08-2	A/C control module (Auto)	M50-B	Power Distribution Module(PDM)	G06	Ground (DSL)
M09-1	A/C control module (Manual)	M51-A	Button relay box	G61	Ground
M09-2	A/C control module (Manual)	M51-B	Button relay box		
M10	Rear parking assist buzzer	M53	Joint connector		
M11	Cigarette lighter	M54	Joint connector		
M12	Digital clock	M55	Joint connector		
M13	FET (Field Effect Transistor)	M56	Joint connector		
M14	Key solenoid	M61	Blower resistor		
M15	Start stop button switch (With Button starting)	M63	Smart key antenna #1		
M16	Electronic steering column lock	M70-1	SRS control module		
M17	Blower motor	M71	Driver air bag		
M18	Data link connector	M72	Passenger air bag		
M19	PTC heater (DSL)	M74	PAB cut off switch		
M20	Front power outlet	M75	Fob holder		
M21	Pre-Excitation resistor (DSL)	EM21	Connection with FRONT harness		
M22	Rheostat	EM31	Connection with FRONT harness		
M23	Active incar sensor	I/P-A	Connection with I/P JUNCTION BOX (LHD)		
M24	Evaporator sensor	I/P-B	Connection with I/P JUNCTION BOX (LHD)		
M25	Auto light & Photo sensor	I/P-C	Connection with I/P JUNCTION BOX (LHD)		
M26	Steering angle sensor	I/P-D	Connection with I/P JUNCTION BOX (LHD)		
M27	Water temperature sensor	I/P-E	Connection with I/P JUNCTION BOX (LHD)		
M29	PAB display	I/P-FR	Connection with I/P JUNCTION BOX (RHD)		
		I/P-GR	Connection with I/P JUNCTION BOX (RHD)		

#### GLOVE BOX EXT. HARNESS

M59	Glove box lamp
M60	Glove box lamp switch
MM01	Connection with MAIN harness

#### MULTIMEDIA JACK EXT. HARNESS

M68	Front acc socket (With AUX & USB)
M69	Multimedia jack (With AUX & USB)
MM02	Connection with MAIN harness (With AUX & USB)

Front Harness & Front End Module Harness (1)

HL-3

**FRONT HARNESS**

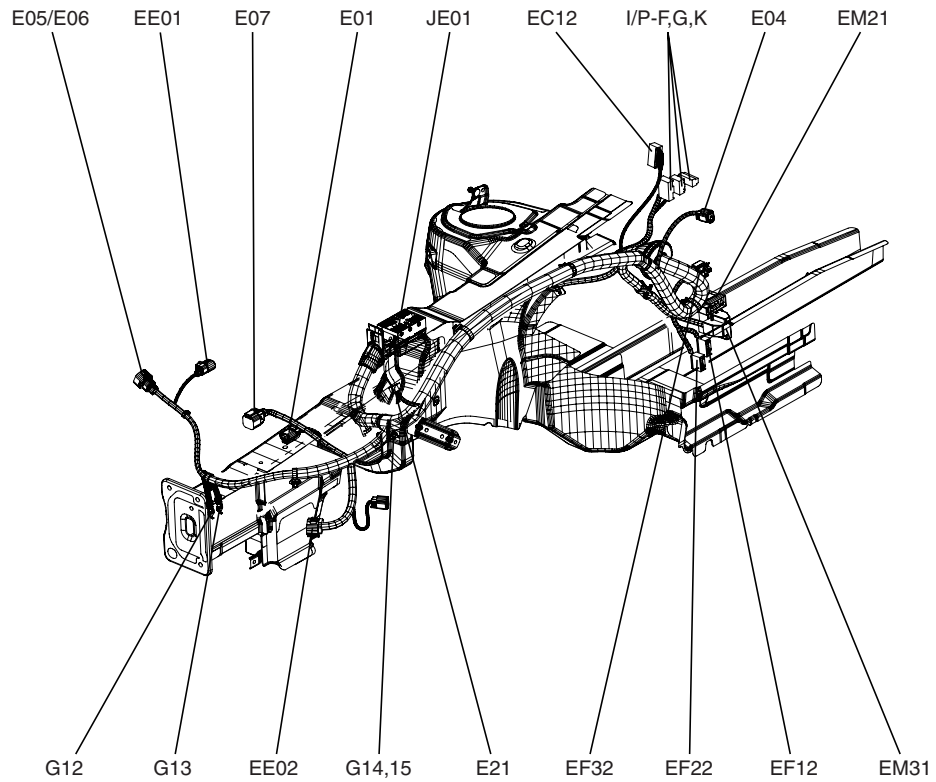

(Left side fender removed)

**FRONT END MODULE HARNESS**

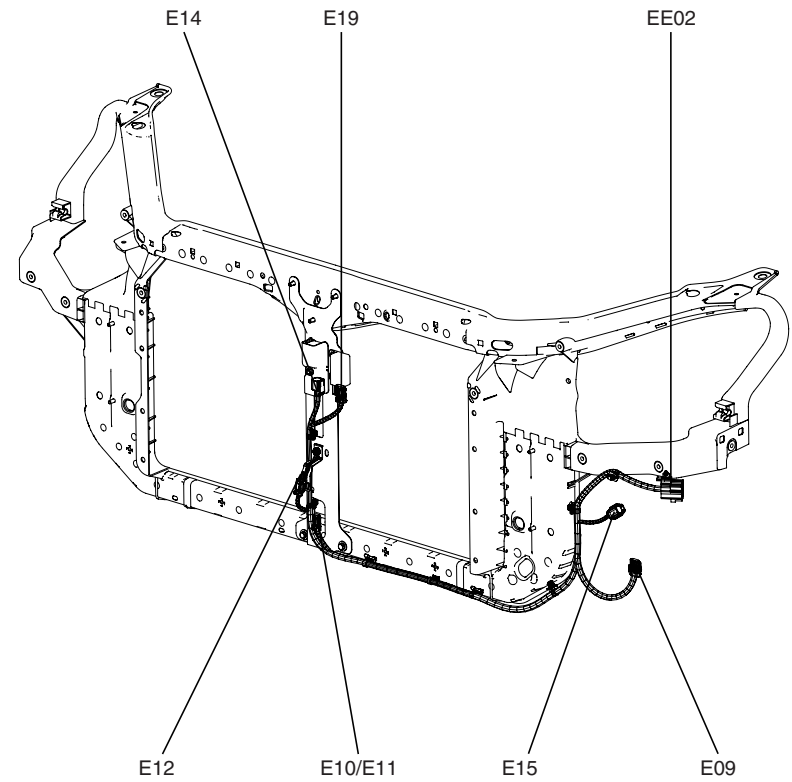

(Front bumper removed)

# FRONT HARNESS & FRONT END MODULE HARNESS

## Front Harness & Front End Module Harness (2)

HL-4

### FRONT HARNESS

E01	Head lamp leveling actuator LH
E04	Side repeater lamp LH
E05	Cooling fan motor (DSL)
E06	Cooling fan motor (GSL)
E07	Head lamp LH
E21	External buzzer (With button starting)
EC12	Connection with CONTROL DASH harness
EE01	Connection with BATTERY harness
EE02	Connection with FRONT END MODULE harness
EF12	Connection with FLOOR harness
EF22	Connection with FLOOR harness
EF32	Connection with FLOOR harness (RHD)
EM21	Connection with MAIN harness
EM31	Connection with MAIN harness
I/P-F	Connection with I/P JUNCTION BOX
I/P-G	Connection with I/P JUNCTION BOX
I/P-K	Connection with I/P JUNCTION BOX
JE01	Connection with E/R JUNCTION BOX
G12	Ground
G13	Ground
G14	Ground
G15	Ground

### FRONT END MODULE HARNESS

E09	Front fog lamp LH
E10	Ambient temperature sensor(GSL)
E11	Ambient temperature sensor(DSL)
E12	Ambient temperature sensor
E14	Front impact sensor
E15	Horn LH
E19	Horn RH
EE02	Connection with FRONT harness

### BATTERY HARNESS

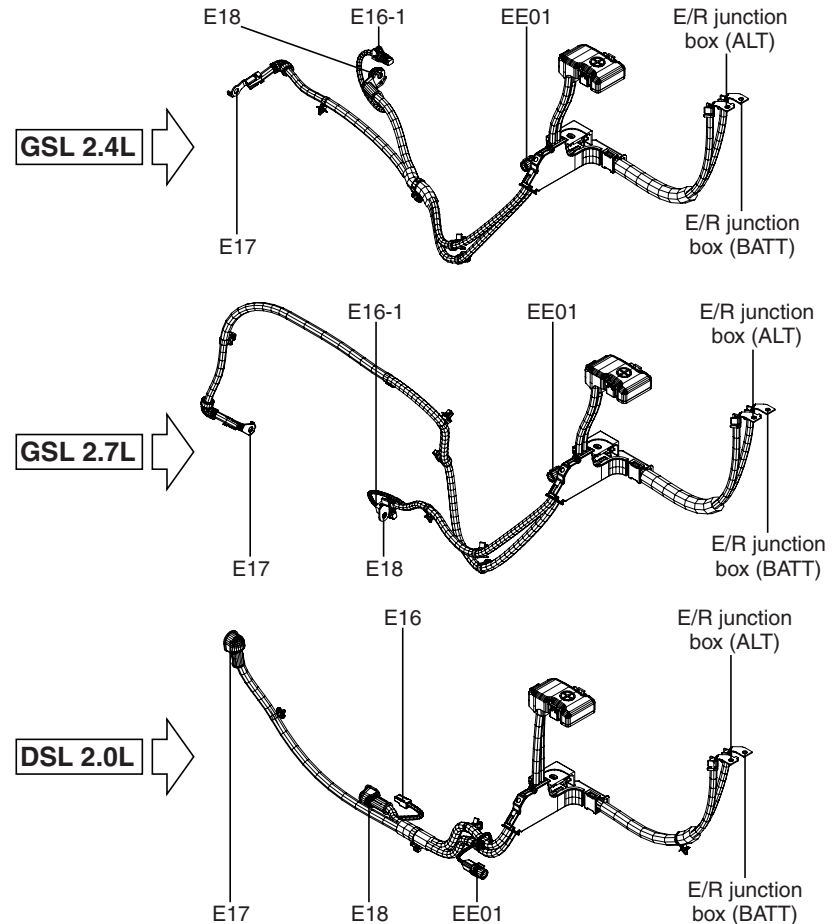

### BATTERY HARNESS

E16	Start solenoid (GSL)
E16-1	Start solenoid (DSL)
E17	Generator
E18	Start motor
EE01	Connection with FRONT harness



# FLOOR HARNESS HARNESS

E7C61A8F

## Floor Harness (1)

HL-5

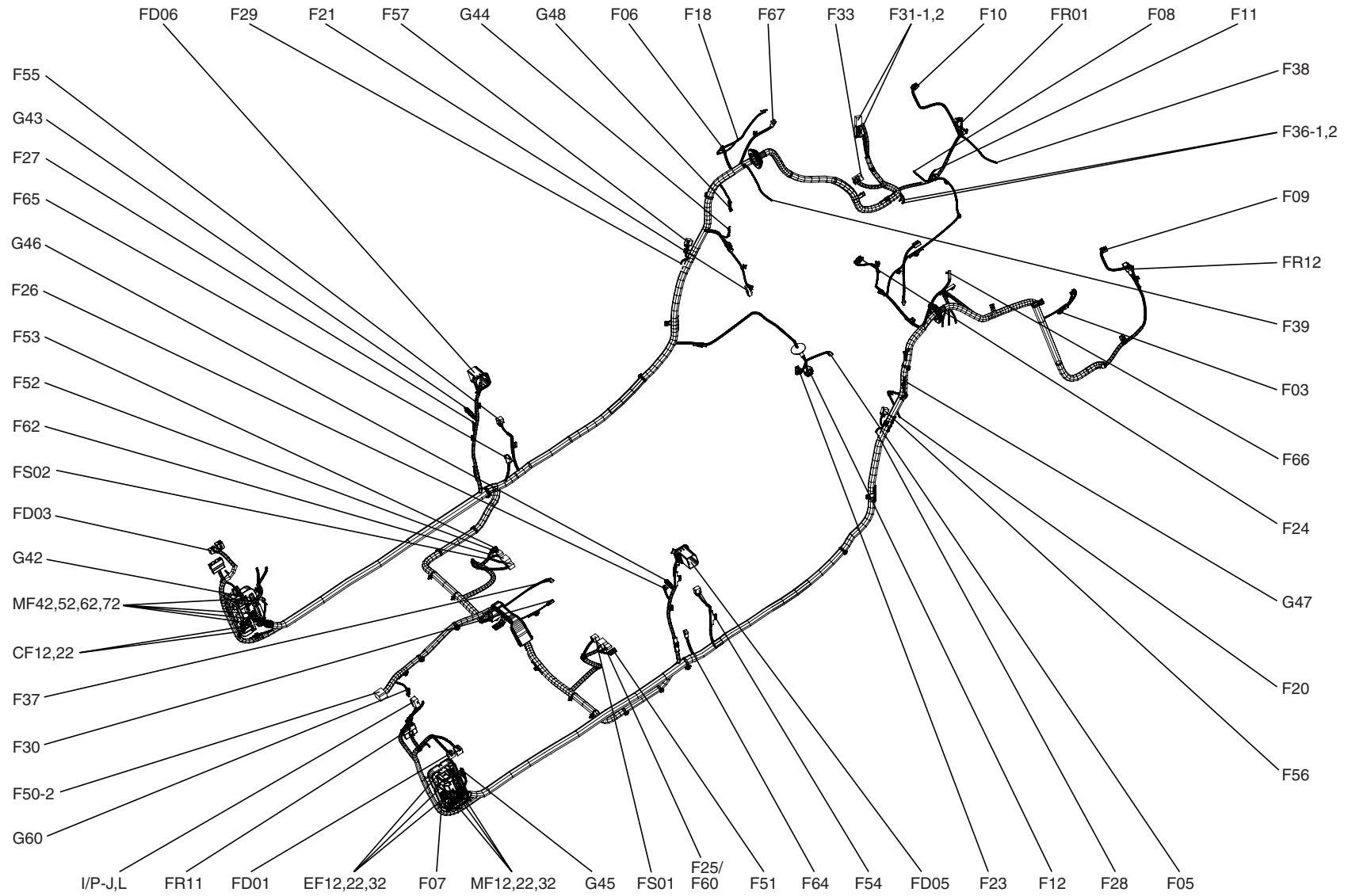

## FLOOR HARNESS HARNESS

### Floor Harness (2)

HL-6

#### FLOOR HARNESS

F03	Fuel filler actuator	F64	Driver seat belt pretensioner
F06	Glass antenna module	F65	Passenger seat belt pretensioner
F07	Joint connector	F66	Driver curtain air bag
F08	High-mounted stop lamp	F67	Passenger curtain air bag
F09	Rear combination lamp LH(OUT)	CF12	Connection with CONTROL DASH harness
F10	Rear combination lamp RH(OUT)	CF22	Connection with CONTROL DASH harness
F11	Trunk room lamp	EF12	Connection with FRONT harness
F12	Fuel sender & Fuel pump motor	EF22	Connection with FRONT harness
F18	Rear window defogger (+)	EF32	Connection with FRONT harness (RHD)
F20	Rear wheel sensor LH	FD01	Connection with FRONT DOOR LH harness
F21	Rear wheel sensor RH	FD03	Connection with FRONT DOOR RH harness
F24	Woofers speaker	FD05	Connection with REAR DOOR LH harness
F25	Driver seat buckle switch	FD06	Connection with REAR DOOR RH harness
F26	Front door switch LH	FR01	Connection with BWS EXT. harness
F27	Front door switch RH	FR11	Connection with ROOF harness
F28	Rear door switch LH	FR12	Connection with TRUNK LID harness
F29	Rear door switch RH	FS01	Connection with DRIVER SEAT harness
F30	Parking brake switch	FS02	Connection with PASSENGER SEAT harness
F31-1	Audio AMP	I/P-J	Connection with I/P JUNCTION BOX
F31-2	Audio AMP	I/P-L	Connection with I/P JUNCTION BOX
F33	Rear parking assist control module	MF12	Connection with MAIN harness
F36-1	Smart key module	MF22	Connection with MAIN harness
F36-2	Smart key module	MF32	Connection with MAIN harness
F37	Smart key antenna #2	MF42	Connection with MAIN harness
F38	Smart key antenna #3	MF52	Connection with MAIN harness
F39	RF receiver (With smart key)	MF62	Connection with MAIN harness
F50-2	SRS control module	MF72	Connection with MAIN harness
F51	Driver side air bag	MF82	Connection with MAIN harness (RHD)
F52	Passenger side air bag	G42	Ground
F53	Seat belt reminder mat	G43	Ground
F54	Driver front side impact sensor	G44	Ground
F55	Passenger front side impact sensor	G45	Ground
F56	Driver rear side impact sensor	G46	Ground
F57	Passenger rear side impact sensor	G47	Ground
F60	Driver seat buckle switch	G48	Ground
F62	Passenger seat buckle switch	G60	Ground

Control Harness (1)

HL-7

DASH(GSL)

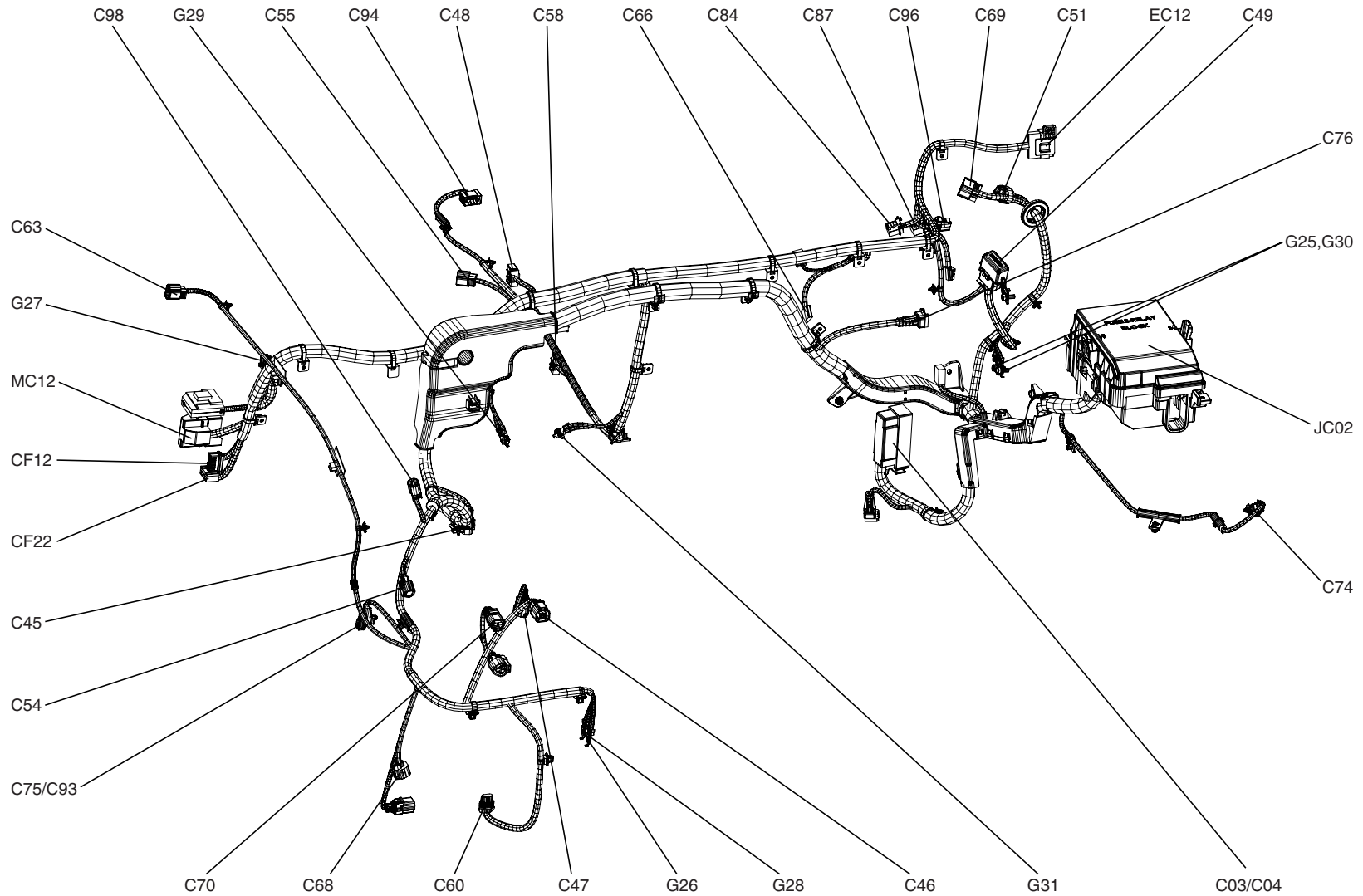

## CONTROL HARNESS

### Control Harness (2)

HL-8

#### CONTROL DASH(GSL) HARNESS

C03	ESP control module	CF12	Connection with FLOOR harness
C04	ABS control module	CF22	Connection with FLOOR harness
C45	Oxygen sensor(UP)	EC12	Connection with FRONT harness
C46	Head lamp leveling actuator RH	JC02	Connection with E/R JUNCTION BOX
C47	A/C pressure transducer(2.7L)	MC12	Connection with MAIN harness
C48	Sport mode switch	G25	Ground
C49	Multipurpose check connector	G26	Ground
C51	Windshield defogger	G28	Ground
C54	Burglar horn	G29	Ground
C55	Oxygen sensor(DOWN)	G30	Ground
C58	Joint connector	G31	Ground
C60	Front fog lamp RH		
C63	Side repeater lamp RH		
C66	Accel position sensor		
C68	Washer motor		
C69	Wiper motor		
C70	Head lamp RH		
C74	Front wheel sensor LH		
C75	Front wheel sensor RH		
C76	Brake fluid level sensor		
C84	Stop lamp switch		
C87	Stop lamp switch(2.0L)		
C93	Front wheel sensor		
C94	YAW rate sensor		
C96	Cruise clutch pedal position switch(M/T)		
C98	Hood switch		

# CONTROL HARNESS

## Control Harness (3)

HL-9

### DASH(DSL)

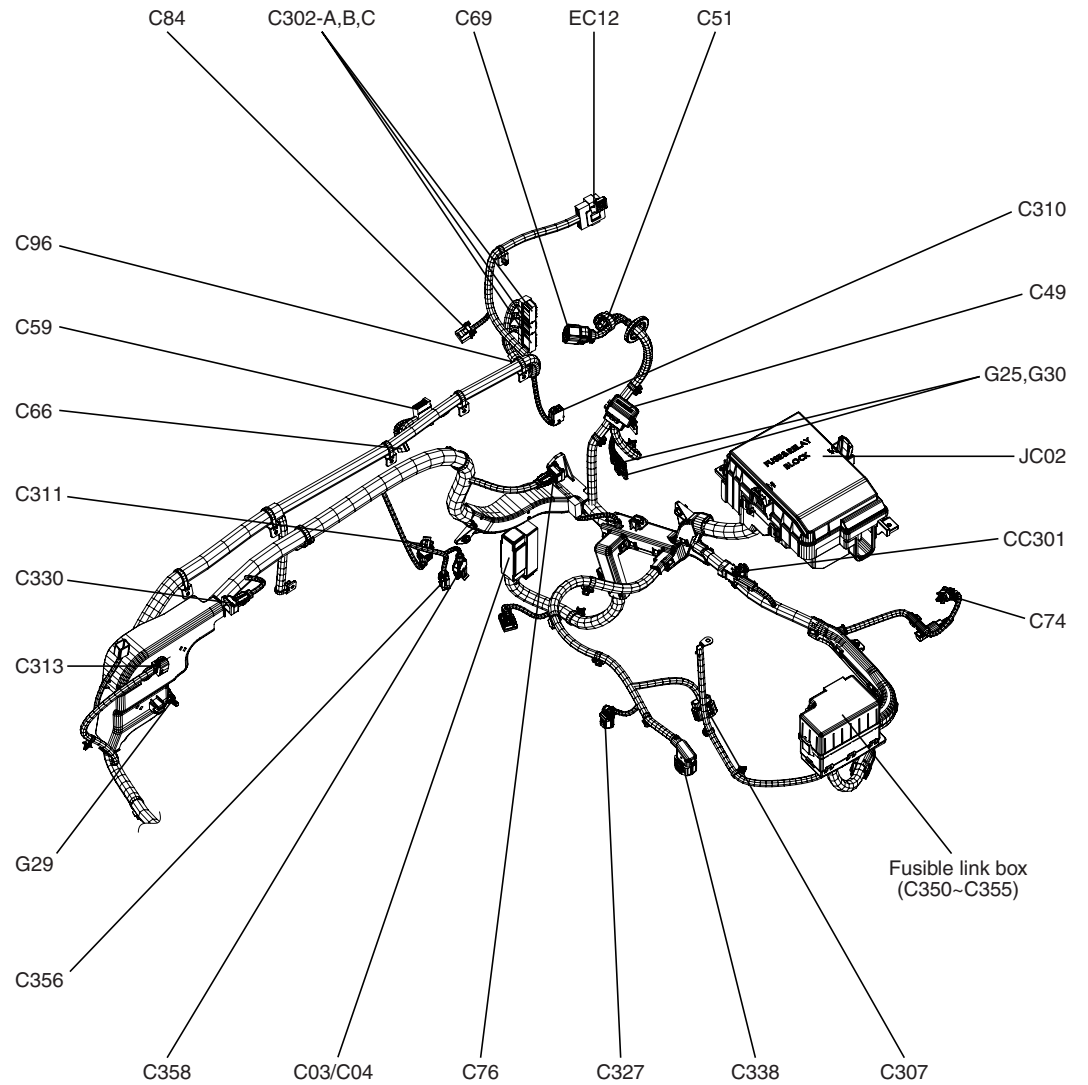
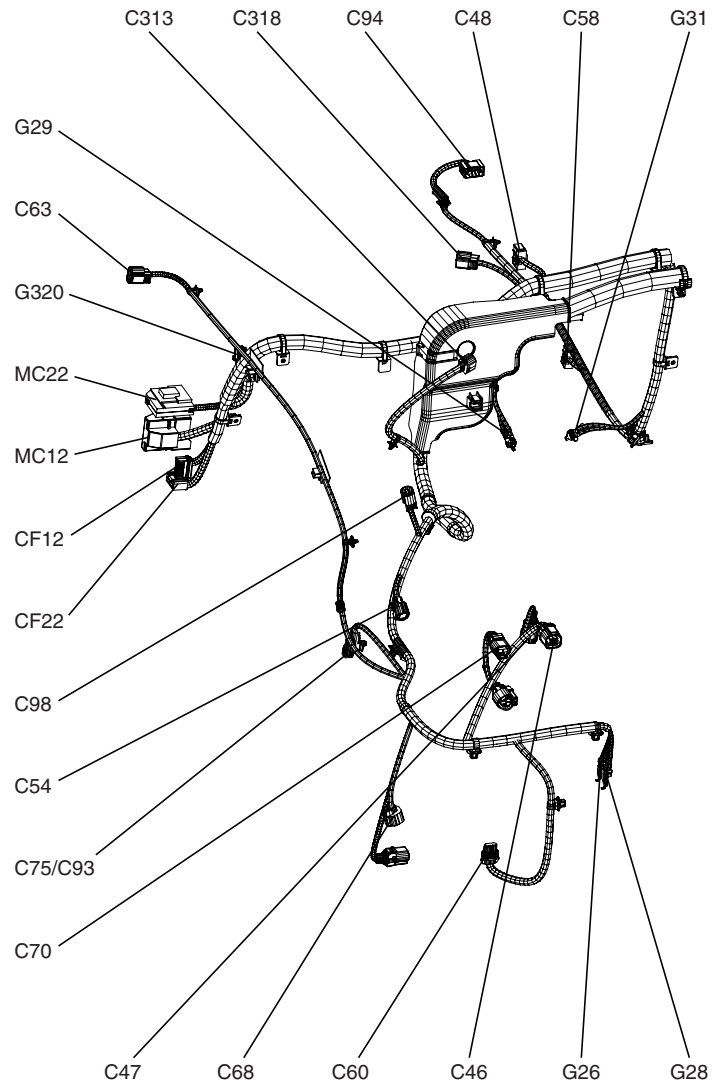

## CONTROL HARNESS

### Control Harness (4)

HL-10

#### CONTROL DASH(DSL) HARNESS

C03	ESP control module	C310	ATM control relay
C04	ABS control module	C311	Thermo switch
C46	Head lamp leveling actuator RH	C313	Differential pressure sensor
C47	A/C pressure transducer	C318	Exhaust gas temperature sensor #2
C48	Sport mode switch	C327	Pulse generator "A"
C49	Multipurpose check connector	C330	VGT actuator
C51	Windshield defogger	C338	Transaxle range switch
C54	Burglar horn	C350	Glow plug relay
C58	Joint connector	C351	PTC heater relay #1
C59	Joint connector	C352	PTC heater relay #2
C60	Front fog lamp RH	C353	PTC heater relay #3
C63	Side repeater lamp RH	C355	Fuel filter heater relay
C66	Accel pedal position sensor	C356	Fuel filter heater
C68	Washer motor	C358	Fuel filter warning switch
C69	Wiper motor	CC301	Connection with CONTROL harness
C70	Head lamp RH	CF12	Connection with FLOOR harness
C74	Front wheel sensor LH	CF22	Connection with FLOOR harness
C75	Front wheel sensor RH	EC12	Connection with FRONT harness
C76	Brake fluid level sensor	JC02	Connection with E/R JUNCTION BOX
C84	Stop lamp switch	MC12	Connection with MAIN harness
C93	Front wheel sensor	MC22	Connection with MAIN harness
C94	YAW rate sensor	G25	Ground
C96	Cruise clutch pedal position switch(M/T)	G26	Ground
C98	Hood switch	G28	Ground
C302-A	TCM	G29	Ground
C302-B	TCM	G30	Ground
C302-C	TCM	G31	Ground
C307	ATM solenoid	G320	Ground

# CONTROL HARNESS

## Control Harness (5)

HL-11

2.0L/2.4L

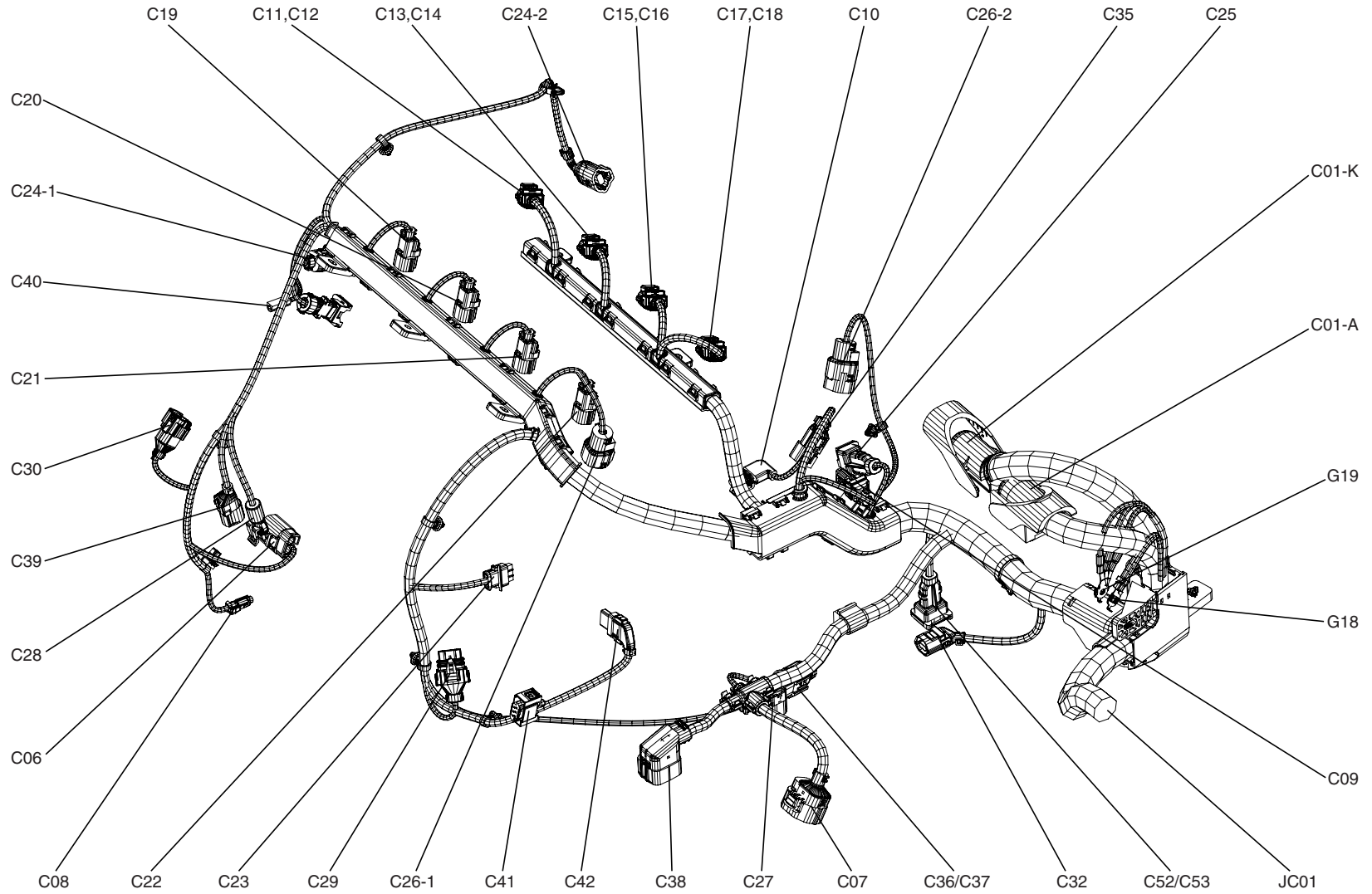

## CONTROL HARNESS

### Control Harness (6)

HL-12

#### CONTROL HARNESS(2.0L/2.4L)

C01-A	PCM	C36	Back-up lamp switch(2.0L, M/T)
C01-K	PCM	C37	Back-up lamp switch(2.4L, M/T)
C06	Generator	C38	Transaxle range switch
C07	ATM solenoid	C39	Oil pressure switch
C08	A/C compressor	C40	Power steering switch
C09	Condenser	C41	ETC motor & Throttle position sensor(2.4L)
C10	Canister purge solenoid valve	C42	Throttle position sensor(2.0L)
C11	Ignition coil #1(With IMMO)	C47	A/C pressure transducer
C12	Ignition coil #1(W/O IMMO)	C52	Vehicle speed sensor(2.0L,M/T)
C13	Ignition coil #2(With IMMO)	C53	Vehicle speed sensor(2.4L,M/T)
C14	Ignition coil #2(W/O IMMO)	JC01	Connection with E/R JUNCTION BOX
C15	Ignition coil #3(With IMMO)	G18	Ground
C16	Ignition coil #3(W/O IMMO)	G19	Ground
C17	Ignition coil #4(With IMMO)		
C18	Ignition coil #4(W/O IMMO)		
C19	Injector #1		
C20	Injector #2		
C21	Injector #3		
C22	Injector #4		
C23	Idle speed control actuator(2.0L)		
C24-1	Oil control valve #1		
C24-2	Oil control valve #2		
C25	Crankshaft position sensor		
C26-1	Camshaft position sensor #1		
C26-2	Camshaft position sensor #2		
C27	Pulse generator "A"		
C28	Knock sensor		
C29	Manifold absolute pressure sensor		
C30	Variable intake manifold valve		
C32	Pulse generator "B"		
C35	Engine coolant temperature sensor		



# CONTROL HARNESS

## Control Harness (7)

HL-13

2.7L

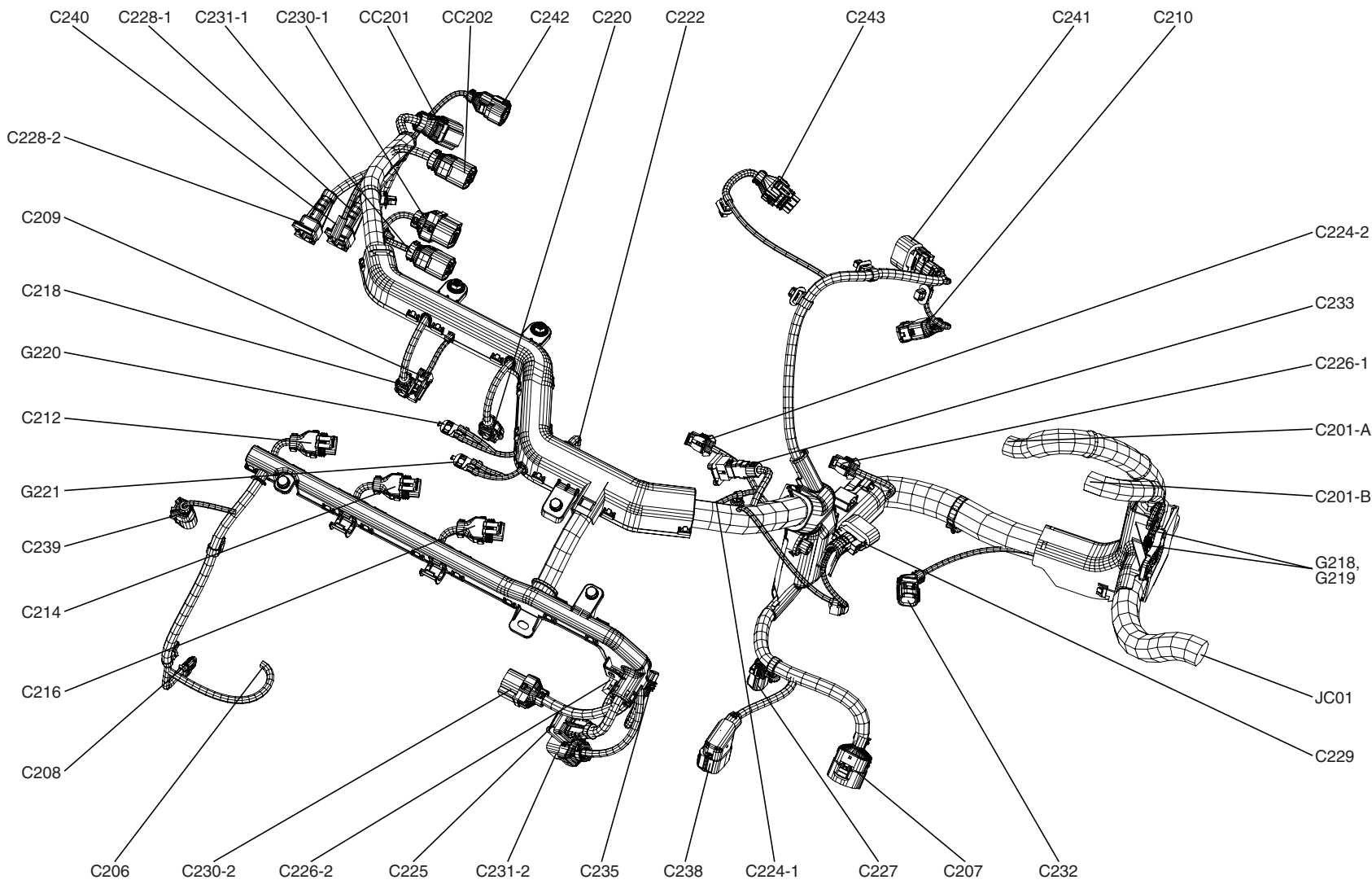

## CONTROL HARNESS

### Control Harness (8)

HL-14

#### CONTROL HARNESS(2.7L)

C201-A PCM  
C201-B PCM  
C206 Generator  
C207 ATM solenoid  
C208 A/C compressor  
C209 Condenser  
C210 Canister purge solenoid valve  
C212 Ignition coil #2  
C214 Ignition coil #4  
C216 Ignition coil #6  
C218 Injector #2  
C220 Injector #4  
C222 Injector #6  
C224-1 Oil control valve #1  
C224-2 Oil control valve #2  
C225 Crankshaft position sensor  
C226-1 Camshaft position sensor #1  
C226-2 Camshaft position sensor #2  
C227 Pulse generator "A"  
C228-1 Knock sensor #1  
C228-2 Knock sensor #2  
C229 Mass air flow sensor  
C230-1 Oxygen sensor(B1/S1)  
C230-2 Oxygen sensor(B2/S1)  
C231-1 Oxygen sensor(B1/S2)  
C231-2 Oxygen sensor(B2/S2)  
C232 Pulse generator "B"  
C233 Oil temperature sensor  
C235 Engine coolant temperature sensor  
C238 Transaxle range switch  
C239 Oil pressure switch  
C240 Power steering switch  
C241 ETC motor & Throttle position sensor

C242 Variable intake manifold valve  
C243 Manifold absolute pressure sensor  
CC201 Connection with IGNITION COIL harness  
CC202 Connection with INJECTOR harness  
JC01 Connection with E/R JUNCTION BOX  
G218 Ground  
G219 Ground  
G220 Ground  
G221 Ground

#### IGNITION COIL HARNESS(2.7L)

C211 Ignition coil #1  
C213 Ignition coil #3  
C215 Ignition coil #5  
CC201 Connection with CONTROL harness

#### INJECTOR HARNESS(2.7L)

C217 Injector #1  
C219 Injector #3  
C221 Injector #5  
CC202 Connection with CONTROL harness

# CONTROL HARNESS

## Control Harness (9)

HL-15

DSL

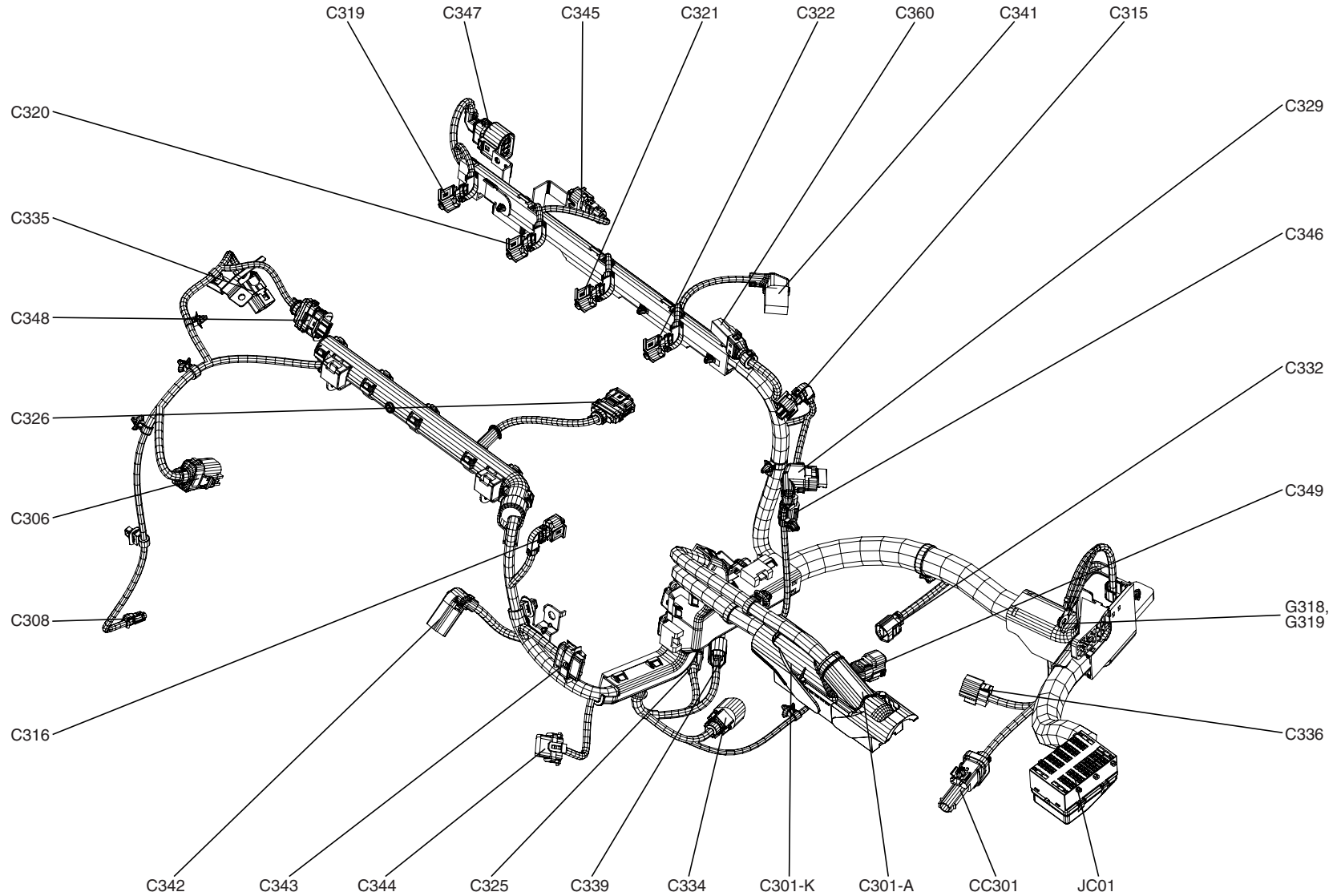

## CONTROL HARNESS

### Control Harness (10)

HL-16

#### CONTROL HARNESS(DSL)

C301-A	PCM
C301-K	PCM
C306	Generator
C308	A/C compressor
C315	Fuel pressure regulating valve
C316	Rail pressure regulator
C319	Injector #1
C320	Injector #2
C321	Injector #3
C322	Injector #4
C325	Crankshaft position sensor
C326	Camshaft position sensor
C329	Mass air flow sensor
C332	Pulse generator "B"
C334	Vehicle speed sensor(M/T)
C335	Engine coolant temperature sensor
C336	Back-up lamp switch
C339	Oil pressure switch
C341	EGR actuator
C342	Throttle control actuator
C343	Variable swirl actuator
C344	Boost pressure sensor
C345	Exhaust gas temperature sensor #1
C346	Fuel temperature sensor
C347	Lambda sensor
C348	Rail pressure sensor
C349	Neutral switch
C360	Glow plug
CC301	Connection with CONTROL DASH harness
JC01	Connection with E/R JUNCTION BOX
G318	Ground
G319	Ground

**Door Harness (1)**

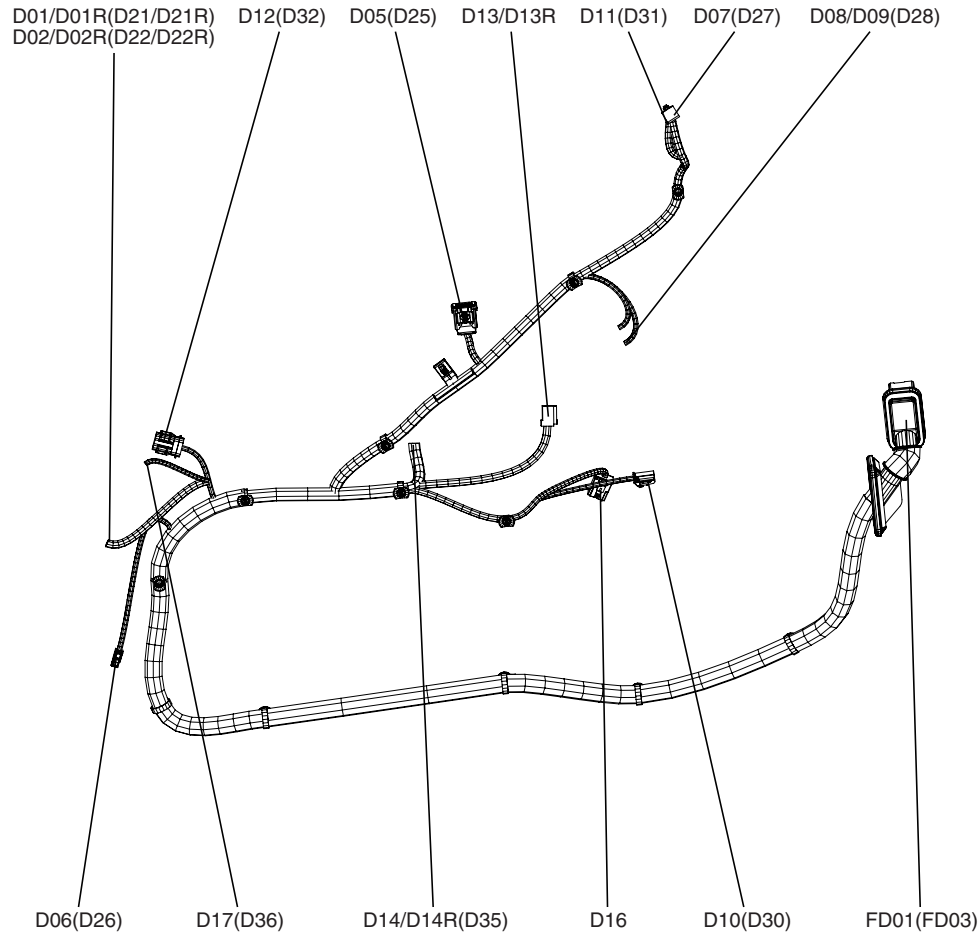

( ): Passenger

**DRIVER DOOR HARNESS**

- D01 Driver door lock actuator (LHD,W/O Dead Lock)
- D01R Driver door lock actuator (RHD,W/O Dead Lock)
- D02 Driver door lock actuator (LHD,With Dead Lock)
- D02R Driver door lock actuator (RHD,With Dead Lock)
- D05 Joint connector
- D06 Driver door lamp
- D07 Driver outside mirror motor
- D08 Driver power window motor (W/O Safety Window)
- D09 Safety window motor
- D10 Driver door speaker
- D11 Driver tweeter speaker
- D12 Driver door unlock switch
- D13 Power outside mirror switch (LHD)
- D13R Power outside mirror switch (RHD)
- D14 Driver power window switch (LHD)
- D14R Driver power window switch (RHD)
- D16 Fuel filler door & Trunk lid switch
- D17 Driver smart outside handle
- FD01 Connector with FLOOR harness

**PASSENGER DOOR HARNESS**

- D21 Passenger door lock actuator (LHD,W/O Dead Lock)
- D21R Passenger door lock actuator (RHD,W/O Dead Lock)
- D22 Passenger door lock actuator (LHD,With Dead Lock)
- D22R Passenger door lock actuator (RHD,With Dead Lock)
- D25 Joint connector
- D26 Passenger door lamp
- D27 Passenger outside mirror motor
- D28 Passenger power window motor
- D30 Passenger door speaker
- D31 Passenger tweeter speaker
- D32 Passenger door unlock switch
- D35 Passenger power window switch
- D36 Passenger smart outside handle
- FD03 Connector with FLOOR harness

# DOOR HARNESS

## Door Harness (2)

HL-18

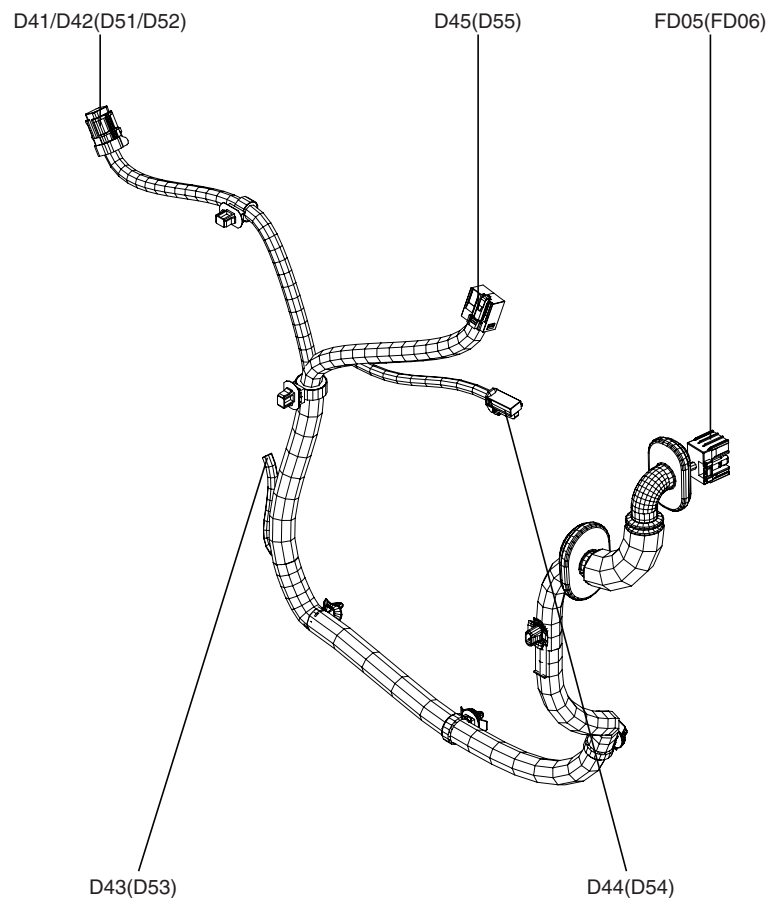

### REAR DOOR LH HARNESS

- D41 Rear door lock actuator LH (W/O Dead Lock)
- D42 Rear door lock actuator LH (With Dead Lock)
- D43 Rear power window motor LH
- D44 Rear door speaker LH
- D45 Rear power window switch LH
- FD05 Connector with FLOOR harness

### REAR DOOR RH HARNESS

- D51 Rear door lock actuator RH (W/O Dead Lock)
- D52 Rear door lock actuator RH (With Dead Lock)
- D53 Rear power window motor RH
- D54 Rear door speaker RH
- D55 Rear power window switch RH
- FD06 Connector with FLOOR harness

( ): Right

Roof Harness (1)

**WITH SUNROOF**

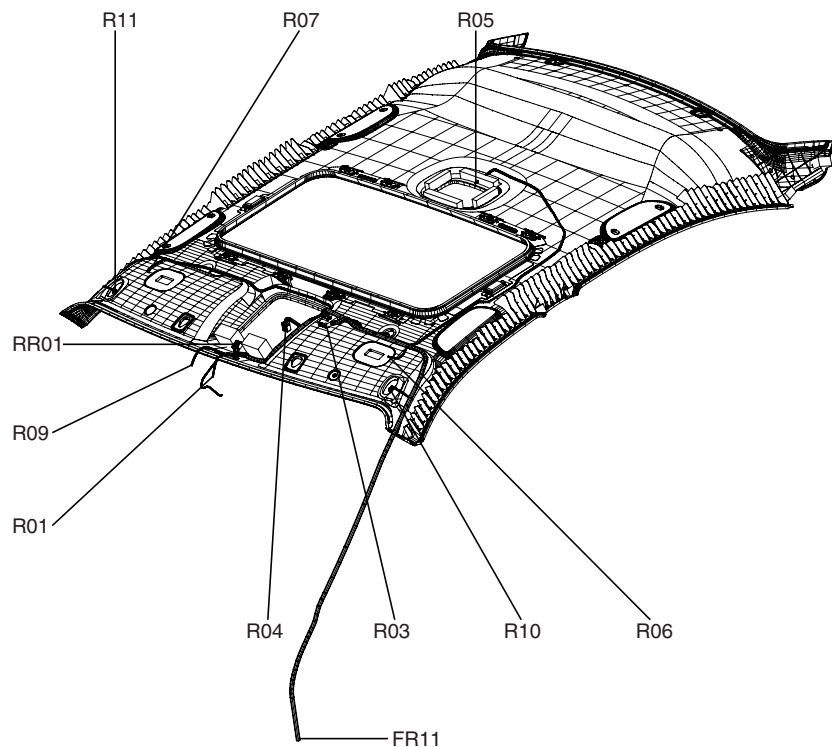

**W/O SUNROOF**

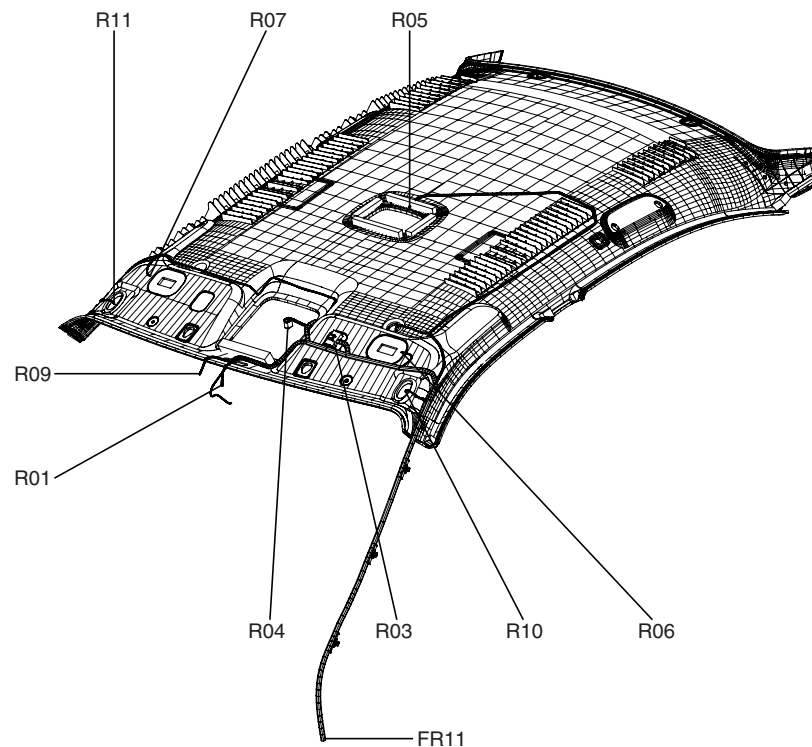

**ROOF HARNESS**

- R01 Electro chromic mirror
- R03 Joint connector
- R04 Overhead console
- R05 Room lamp
- R06 Vanity lamp LH
- R07 Vanity lamp RH
- R09 Rain sensor
- R10 Vanity lamp switch LH
- R11 Vanity lamp switch RH
- FR11 Connection with FLOOR harness
- RR01 Connection with SUNROOF harness

**SUNROOF HARNESS**

- R22 Sunroof control module
- RR01 Connection with ROOF harness

Trunk Lid Harness (1)

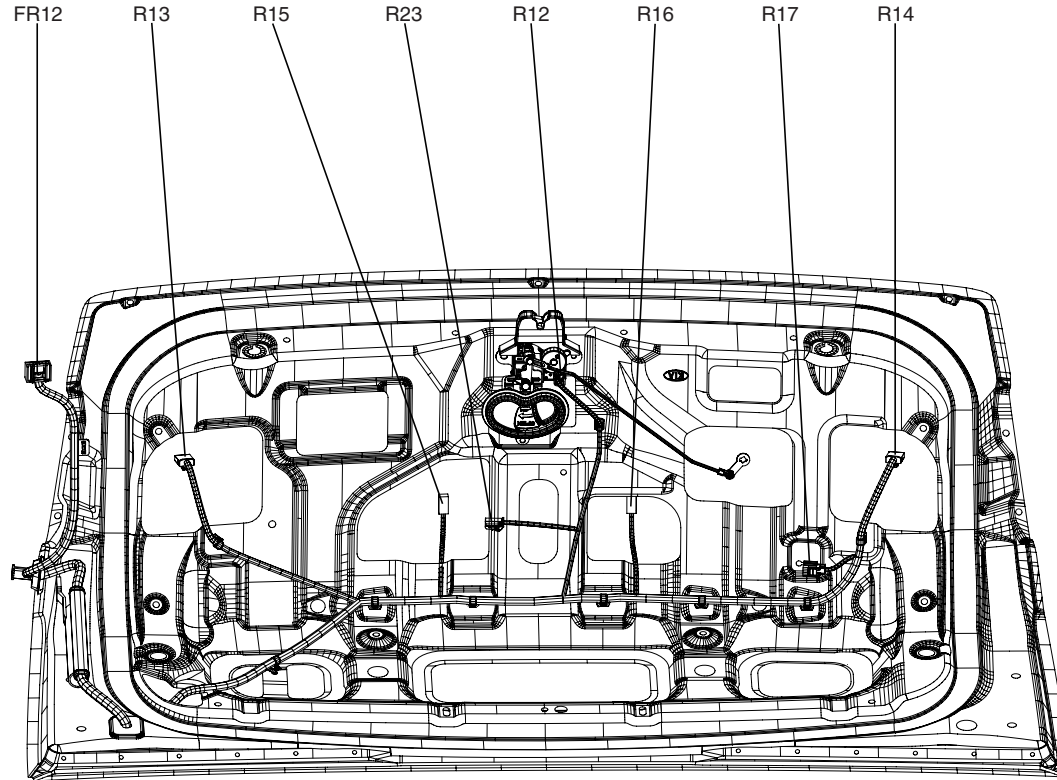

**TRUNK LID HARNESS**

- R12 Trunk lid latch
- R13 Rear combination lamp LH(IN)
- R14 Rear combination lamp RH(IN)
- R15 License lamp LH
- R16 License lamp RH
- R17 Trunk unlock switch
- R23 Trunk lid switch(With Button Starting)
- FR12 Connection with FLOOR harness

**BWS EXT. HARNESS**

- R19 Rear parking assist sensor LH
- R20 Rear parking assist sensor CTR
- R21 Rear parking assist sensor RH
- R26 Smart key bumper antenna
- FR01 Connection with FLOOR harness

**REAR WINDOW DEFOGGER HARNESS**

- R18 Rear window defogger(-)
- G62 Ground



**DRIVER SEAT**

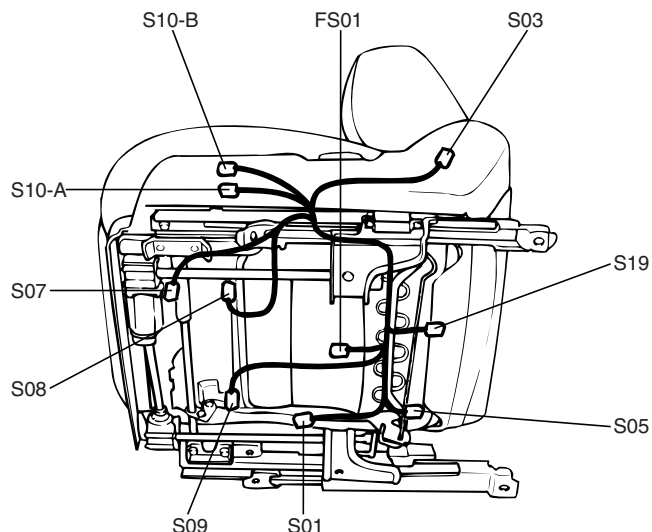

**DRIVER SEAT HARNESS**

- S01 Driver slide limit switch
- S03 Driver reclining limit switch
- S05 Driver reclining motor
- S07 Driver slide motor
- S08 Front height adjuster motor
- S09 Rear height adjuster motor
- S10-A Driver seat manual switch
- S10-B Driver seat manual switch
- S19 Driver cushion warmer
- FS01 Connection with FLOOR harness

**PASSENGER SEAT**

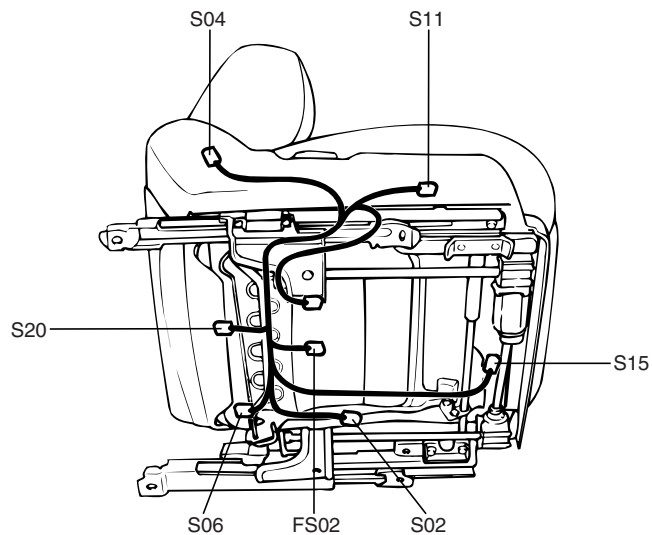

**PASSENGER SEAT HARNESS**

- S02 Passenger slide limit switch
- S04 Passenger reclining limit switch
- S06 Passenger reclining motor
- S11 Passenger seat manual switch
- S15 Passenger slide motor
- S20 Passenger cushion warmer
- FS02 Connection with FLOOR harness